

Repair Manual



K 1100 LT/RS

**BMW AG Motorcycle Division
After Sales**

Published by BMW AG Motorcycle Division
After Sales
UX-VS-2

All rights reserved. Not to be reprinted, translated or duplicated either wholly or in part without prior written permission.
Errors and omissions excepted; subject to technical amendment.

Produced in Germany 5/99

Introduction

This repair manual will help you to perform all the main maintenance and repair work correctly and efficiently. If it is consulted regularly by workshop personnel it will form a useful addition to the theoretical and practical knowledge acquired at the BMW Training Centre. It is a contribution towards achieving even higher Service quality.

All information in both text and illustrations refers to motorcycles in standard condition or with genuine BMW accessories installed, and not to motorcycles which have been modified in any way to depart from the manufacturer's specification.

- The repair manual is structured in the logical sequence of the work to be performed: Removal, Disassembly, Repair, Assembly, Installation.
- The entire contents are divided into individual chapters, corresponding to the Construction Groups.

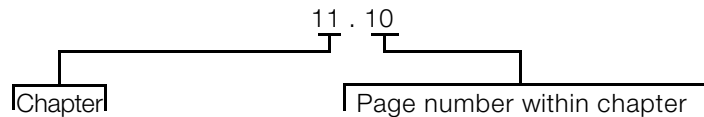

- Work to be performed during an Inspection is described in Group "00". The various inspection routines are numbered I, II, III and IV. This numbering is repeated in the work descriptions which follow, so that work can take place without interruption.
- Use of the BMW special tools needed for certain tasks is described in the work instructions.

If the need arises, repair instructions are also issued in the form of Service Information. This information is of course incorporated into the next issue of the repair manual. We also recommend, as an additional source of information, the Electronic Parts Catalogue (ETC), which contains clear and easy-to-follow illustrations.

If the work described here is restricted to a particular equipment specification, for instance if a specific optional extra (OE) is fitted, this is stated in square brackets at the start of the item concerned, e.g. **[LT]**.

Please refer to the following pages as well for a description of other symbols used and how to work with it.

BMW AG Motorcycle Division
After Sales

Published by: BMW AG Motorcycle Division
 After Sales
 UX-VS-2

D - 80788 München

All rights reserved. Not to be reprinted, translated or duplicated either wholly or in part without prior written permission.

Errors and omissions excepted; subject to technical amendment.

Produced in Germany

Usage

Each chapter starts with the list of contents.

The list of contents is followed by the Technical Data table.

Chapter 00 "Maintenance and general instructions" details the handover checklist and lists all tightening torques and operating fluids.

Key to symbols

In this Workshop Manual for the K 1200 LT model, the following symbols are used; their meanings are explained in the table.

Special instructions aimed at improving the work procedures



Note:

Specific information on operating, inspecting and adjusting work for the motorcycle as well as maintenance procedures.



Caution:

Instructions and precautions specifically intended to prevent damage to the motorcycle. Failure to comply with them could invalidate the warranty.



Caution:

This symbol stands for precautions and measures which are essential in order to protect the rider or other persons from possibly severe or fatal injury.

Contents

Headlines for the work described in the chapter..... with the relevant page number



Tightening torques:

Values are stated if they differ from DIN EN 24 014 or DIN 912 ISO industrial standards.

BMW AG Motorcycle Division Maintenance Schedule

K 75 RT/K 1100 RS/LT (from 1993 only)



Customer	Registration No.	BMW Inspection 1000 km/600 mls	BMW Service 10000 km/ 6000 miles	BMW Inspection 20 000 km/ 12 000 miles	BMW Annual Service
Order No.	Signature of mechanic				
Change oil when engine at regular operating temperature, renew oil filter element ¹⁾		<input type="checkbox"/>	<input type="checkbox"/>	<input type="checkbox"/>	<input type="checkbox"/>
Change oil in gearbox, final drive and telescopic fork ²⁾		<input type="checkbox"/>		<input type="checkbox"/>	<input type="checkbox"/>
Clean inductive sensor at rear wheel ²⁾				<input type="checkbox"/>	
Grease upper/lower clutch cable nipples and side/centre stand pivots			<input type="checkbox"/>	<input type="checkbox"/>	
Renew intake air cleaner element ³⁾				<input type="checkbox"/>	
Renew fuel filter element ⁴⁾				<input type="checkbox"/>	
Check hose clips on fuel and cooling system for leaks and take up slack if necessary		<input type="checkbox"/>		<input type="checkbox"/>	
Check coolant level and concentration, and top up if necessary				<input type="checkbox"/>	
Renew coolant after at least every 2 years *					<input type="checkbox"/>
Check brake pads and discs for wear, renew if necessary [*]			<input type="checkbox"/>	<input type="checkbox"/>	
Check front/rear brake fluid level, top up if necessary [*] [SI 00 027 95 (716)]		<input type="checkbox"/>	<input type="checkbox"/>	<input type="checkbox"/>	
Check brake system with regard to function, leaks; repair/renew as required [*]				<input type="checkbox"/>	
Renew brake fluid at least once a year					<input type="checkbox"/>
Check sensor gap for ABS at front and rear, adjust if necessary ⁶⁾		<input type="checkbox"/>	<input type="checkbox"/>	<input type="checkbox"/>	
Check sensor/pulse wheel for ABS at front and rear for contamination, clean if necessary ^{6) 5)}			<input type="checkbox"/>	<input type="checkbox"/>	
Check operation of electric side stand switch (angle)		<input type="checkbox"/>	<input type="checkbox"/>	<input type="checkbox"/>	
Check clutch operating clearance, adjust if necessary		<input type="checkbox"/>		<input type="checkbox"/>	
Check free travel at throttle and cold-start (choke) cables, adjust if necessary		<input type="checkbox"/>		<input type="checkbox"/>	
Renew spark plugs				<input type="checkbox"/>	
Read out MOTRONIC fault memory ⁷⁾			<input type="checkbox"/>	<input type="checkbox"/>	
Check valve clearances, adjust if necessary ⁸⁾		<input type="checkbox"/> ⁵⁾		<input type="checkbox"/>	
Check steering head bearing play, adjust if necessary [*]				<input type="checkbox"/>	
Check battery acid level, top up with distilled water if necessary				<input type="checkbox"/>	<input type="checkbox"/>
Clean and grease the battery posts, if necessary				<input type="checkbox"/>	<input type="checkbox"/>
Take up slack at bolts and nuts:					
– power unit to frame					
– suspension strut mounts		<input type="checkbox"/>		<input type="checkbox"/>	
– side/center stand pivot					
– rear wheel studs					
Apply silicone spray to guide rods of adjustable windshield (only K 1100 LT, K 75 RT)				<input type="checkbox"/>	<input type="checkbox"/>
Check idle speed, throttle synchronisation and CO value, adjust if necessary		<input type="checkbox"/>	<input type="checkbox"/>	<input type="checkbox"/>	<input type="checkbox"/>
Final inspection with safety/operating check:					
– condition of tyres and wheels, tyre pressures					
– lights and signal systems					
– telltale and warning lights					
– clutch and gear shift		<input type="checkbox"/>	<input type="checkbox"/>	<input type="checkbox"/>	<input type="checkbox"/>
– handbrake and footbrake, ABS					
– steering					
– instruments					
– test ride, if necessary					

Recommendation: In severe operating conditions, grease the throttle twistgrip and steering head bearings at least every 30,000 km (18,000 miles) ^{*}

¹⁾ at least every 6 months; if motorcycle is used only for short journeys or at outside temperatures below 0°C, every 3 months, and at least every 3,000 km (1,800 miles)

²⁾ at least once a year

³⁾ in very dirty or dusty conditions, renew the intake air cleaner element every 10,000 km (6,000 miles), or even more frequently if necessary

⁴⁾ normally every 40,000 km (24,000 miles), but if fuel is of poor quality every 20,000 km (12,000 miles)

⁵⁾ K 75 models only

⁶⁾ only motorcycles with ABS

⁷⁾ only motorcycles with catalytic converter

⁸⁾ on all K models, renew the lining on the chain tensioner rail every 60,000 km (36,000 miles)

^{*} invoiced as a separate item

BMW AG Motorcycle Division

Pre-delivery Check

K 75 RT/K 1100 RS/LT (from 1993 only)



<p>_____</p> <p>Customer</p> <p>_____</p> <p>Order No.</p>	<p>_____</p> <p>Registration No.</p> <p>_____</p> <p>Signature of mechanic</p>	<p>BMW Pre-delivery check</p>
<p>Inspect crates on receipt for signs of damage</p>		
<p>Motorcycle:</p> <ul style="list-style-type: none"> - unpack - check scope of delivery - install front wheel - complete - clean 		<p><input type="checkbox"/></p>
<p>Battery:</p> <ul style="list-style-type: none"> - remove - add battery acid - charge - grease the terminal posts - re-install (mark date) 		<p><input type="checkbox"/></p>
<p>Check complete specification delivery:</p> <ul style="list-style-type: none"> - tools - handbooks and documents - keys - optional extras 		<p><input type="checkbox"/></p>
<p>Check front and rear wheel brake fluid levels (only disc brake)</p>		<p><input type="checkbox"/></p>
<p>Check switch function of electrically-operated side stand (angle)</p>		<p><input type="checkbox"/></p>
<p>Check torque setting of the rear wheel retaining studs</p>		<p><input type="checkbox"/></p>
<p>Check tyre pressure</p>		<p><input type="checkbox"/></p>
<p>Fuel the motorcycle</p>		<p><input type="checkbox"/></p>
<p>Safety/operating check as final inspection:</p> <ul style="list-style-type: none"> - idle speed - clutch, gear shifting - steering - front and rear brakes, ABS - telltale and warning lights, instruments, lighting and signalling equipment - adjust the headlight - test ride, if necessary 		<p><input type="checkbox"/></p>

Contents

Group / Chapter

00 Maintenance and general instructions	00.1
11 Motor	11.1
12 Engine electrics	12.1
13 Fuel preparation and control	13.1
16 Fuel tank and lines	16.1
17 Radiator	17.1
18 Exhaust system	18.1
21 Clutch	21.1
23 Gearbox	23.1
31 Front fork	31.1
32 Steering	32.1

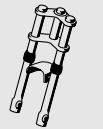
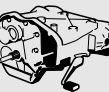
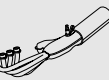
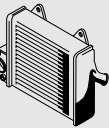
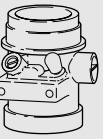
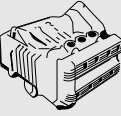

Group / Chapter

33 Rear wheel drive 33.1

34 Brakes 34.1

36 Wheels and tyres..... 36.1

46 Frame 46.1

51 Equipment..... 51.1

61 General electrical equipment 61.1

62 Instruments..... 62.1

63 Lights..... 63.1

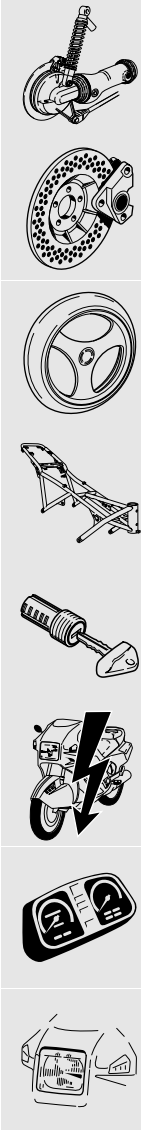

00 Maintenance and general instructions



Contents	Page
Tightening torque	3
Table of operating fluids	10
Key to maintenance intervals	11
Changing engine oil	11
Inspections I, II, III, IV	
Changing oil in transmission (gearbox)	11
Inspections I, III, IV	
Changing oil in rear wheel drive	12
Inspections I, III, IV	
Changing oil in telescopic fork	12
Inspection I, III, IV	
Renewing intake air cleaner	12
Inspection III	
Renewing fuel filter	13
Inspection III	
Cleaning inductive pulse generator at rear wheel drive	13
Inspections I, III, IV	
Checking brake pads, brake discs for wear and renewing if necessary	14
Inspection II, III	
Front wheel brake	
Rear wheel brake	
Checking brake fluid level and correcting if necessary	15
Inspections I, II, III	
Checking brake fluid level	
Adding brake fluid	
Checking brake system	15
Inspection III	
Checking ABS sensor spacing and adjusting if necessary	15
Inspections I, II, III	
Front sensor	
Rear sensor	
Renewing brake fluid	16
Renewing front brake fluid	
Renewing rear brake fluid	



Checking function of electric switch on side stand and adjusting if necessary	17
Inspections I, II, III	
Checking clutch clearance and adjusting if necessary	18
Inspections I, III	
Reading out Motronic defect code memory	18
Inspections II, III	
Checking increased starting speed (choke) and adjusting if necessary	19
Inspections I, III	
Checking increased starting speed	
Checking valve clearance and adjusting if necessary	20
Inspections I, III	
Adjusting valve clearance	20
Removing sprockets	
Removing camshafts	
Installing camshafts	
Installing sprockets	
Installing cylinder head cover	
Checking steering bearing play and adjusting if necessary	23
Inspection III	
Lubricating guide pins, adjustable screen	24
Inspections III, IV	
Checking idle speed, synchronising and CO value and adjusting if necessary	25
Inspections I, II, III, IV	
Adjusting idle speed	
Adjusting CO value without catalytic converter	

Tightening torque

Model	K 1100 LT	K 1100 RS
Connection	Nm	
11 Engine		
Freewheel		
Cover plate/freewheel cage at countershaft gear	10	
Oil - water pump		
Oil pressure switch	40	
Temperature sensor/screw plug	9	
Pressure relief valve	40	
Impeller	33	
Pump housing to crankcase	10	
Cover to pump housing	10 (3-Bond 1209)	
Intermediate flange		
Thrust plate at intermediate flange	9 (Loctite 243)	
Intermediate flange at crankcase	9	
Crankshaft		
Pinion/rotor flange at crankshaft	50	
Main bearing cap to crankcase	50	
Connecting rod		
Big end cap Wrench angle	80 °	30
Input shaft		
Front bearing	18	
Rear bearing	40	
Engine block		
Crankshaft cover	9	
Lower part, outer	10	
Oil sump	10	
Oil filter cover	10	
Oil drain plug	30	
Cylinder head		
Cylinder head bolts (SI 11 062 95 (697) Short thread (from 6/93 to 11/94): Wrench angle, 1st stage Wrench angle, 2nd stage Long thread (since 12/94): Wrench angle, 1st stage Wrench angle, 2nd stage	64° 42° 75° 75°	22 20
Cylinder head cover	9	
Camshaft		
Bearing cap	9 (Apply a thin coat of 3-Bond 1209 only at corners and butt edges)	
Chain sprockets	54	

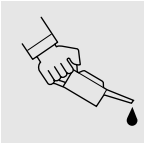



Model	K 1100 LT	K 1100 RS
Connection	Nm	
Timing chain		
Chain tensioner	9	
Slide rail at camshaft bearing cap	9	
Timing case cover		
Timing case cover	10 (3-Bond 1209)	
Cover for Hall-effect signal transmitter	9	
Screw plug	40	
Clutch		
Clutch housing to output shaft Tighten to Release and re-tighten to Wrench angle	50°	140 50
Housing cover	19	
Alternator		
Alternator to intermediate flange	22	
Driver	33	
Starter motor		
Starter motor to gearbox	9	
Mixture preparation		
Intake stub pipe	9	
Fuel injection rail	9	
Cooling system		
Coolant stub pipe at cylinder head	9	
Temperature sensor at coolant stub pipe	30	
Air cleaner		
Lower part of air cleaner housing	21	
12 Engine electrical system		
Starter to transmission	9	
Positive lead to starter	5	
Alternator to intermediate flange	22	
Clutch housing	50	
Base plate	3,5	
Setting ring	2,5	
Hall generator cover	9	
Ignition coils to intermediate flange	5	
Spark plug	20	

Model	K 1100 LT	K 1100 RS
Connection	Nm	
13 Fuel preparation and control		
Injection rail	9	
Intake stub pipe	9	
Lower section of air cleaner housing	21	
Intake air line	9	
Motronic control unit	5	
17 Radiator		
Connecting screw, temperature sensor	9	
Fastening, thermostat cover	3	
Radiator to frame	9	
Coolant stub pipe to cylinder head	9 (with Loctite 243)	
Temperature sensor to coolant stub pipe	30	
18 Exhaust System		
Exhaust system to cylinder head	21	
Front silencer (muffler)	12	
Exhaust system holder to footrest plate	33	
Exhaust system to holder/footrest plate	9	
Retaining bracket to gearbox	41	
Oxygen sensor	Hand-tight	
21 Clutch		
Clutch housing to output shaft tighten to loosen and retighten to tightening angle	50°	140 50
Housing cover	19	

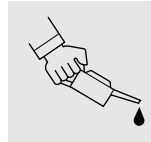

Model	K 1100 LT	K 1100 RS
Connection	Nm	
23 Transmission		
Transmission cover to transmission	9	
Machine screw for neutral stop	13	
Stud bolt, selector shaft	17 (Loctite 243)	
Transmission to intermediate flange	16	
Frame mounting to transmission	45	
Bearing mount to transmission	41 (Loctite 243)	
Starter motor to transmission	9	
Positive lead to starter motor	5	
Fixed bearing of swinging arm to transmission	9	
Swinging arm bearing journal (loose bearing)	7,5	
Locknut of bearing journal	41	
Fixed bearing rear wheel drive in swinging arm	150 (clean thread + Loctite 2701)	
Bearing pin, loose bearing rear wheel drive in swinging arm	7 (clean thread + Loctite 2701)	
Locknut, loose bearing rear wheel drive in swinging arm	105 (clean thread + Loctite 2701)	
Suspension strut to frame/rear wheel drive	51	
Brake caliper	32	
Hinterradschrauben	105	
Exhaust to cylinder head	21	
Silencer to holder/footrest plate	9	
Front silencer to transmission	12	
Footrest plate to transmission	15	
31 Front fork		
Oil filler plug	10	
Oil drain plug	3,5	
Spring support bearing	20	
Locking tube	65	
Hexagon nut	65	
Clamping screws of fork bridges	15	
Bottom screw fitting	47	
Handlebar clamp block	22	
Fork stabilisor	22	



Model	K 1100 LT	K 1100 RS
Connection	Nm	
32 Steering		
Clamping screws for handlebar fitting	5	
Clamping screws	22	
Clamping block to fork bridge	16	
33 Rear wheel drive		
Threaded ring	118 (clean thread + Hylomar SQ 32M)	
Hexagon nut, drive bevel gear	200 (clean thread + Loctite 273)	
Housing cover	35	
Swinging arm fixed bearing to transmission	9	
Swinging arm bearing journal, loose bearing	7 (clean thread + Loctite 2701)	
Locknut, loose bearing	41	
Fixed bearing rear wheel drive in swinging arm	150 (clean thread + Loctite 2701)	
Bearing pin, loose bearing rear wheel drive in swinging arm	7 (clean thread + Loctite 2701)	
Locknut, loose bearing rear wheel drive in swinging arm	105 (clean thread + Loctite 2701)	
Strut to rear wheel drive	43	
Spring strut to frame/rear wheel drive	51	
Brake disc to rear wheel drive	21	
Brake caliper to rear wheel drive	32	
Wheel bolts:	1st stage	50
	2nd stage	105
Oil drain plug	23	
Oil filler plug	23	
Inductive sensor to rear wheel drive	2,5	





Model	K 1100 LT	K 1100 RS
Connection	Nm	
34 Brakes		
ABS pulse wheel	4	
ABS sensor front/rear	4	
Brake caliper to sliding tube/rear wheel drive	40	
Brake line to brake caliper	18	
Bleed screws at brake caliper front	14	
Bleed screws at brake caliper rear	11	
Brake hose to distributor	18	
Brake hose to master brake cylinder	18	
Brake disc to front wheel	24	
Brake disc to rear wheel drive	21	
Foot brake cylinder to foot rest plate	25	
Locknut, adjusting screw foot brake cylinder	9	
Distributor to fork bridge	6	
Brake caliper to sliding tube/rear wheel drive	9	
ABS unit to mounting	9	
Bleed screw at ABS unit	9	
Master brake cylinder to foot rest plate	9	
Mounting pin to handbrake lever	8	
36 Wheels and tyres		
Quick-release axle threaded connection	33	
Quick-release axle clamp screws	14	
Brake caliper to fork slider tube/rear wheel drive	32	
Wheel studs (tighten in the order stated):	50	
1. All studs handtight	105	
2. Preload the outer wheel studs in a crosswise pattern	105	
3. Tighten the central stud		
4. Tighten the outer studs		

Model	K 1100 LT	K 1100 RS
Connection	Nm	
46 Frame		
Frame to engine	45	
Fairing support bracket to frame	9	
Suspension strut to frame/rear wheel drive	51	
Handlebar to clamping block	22	
Clamping screws of fork bridge	15	
Locking tube	65	
Hexagon nut	65	
Centre stand to bearing block	41	
Side stand to bearing block	41	
Footrest plate	15	
Brake line to handbrake cylinder	11	
Brake line to distributor	11	
51 Equipment		
Handlebar clamping blocks	22	
Shear bolts	to shear point (~ 20)	
61 General electrical equipment		
Central earth (ground)	9	
Motronic control unit	5	

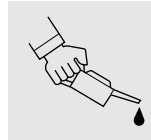



Table of operating fluids



Item	Use	Order number	Quantity
Lubricant			
Optimoly MP 3	High-performance lubricating paste	07 55 9 062 476	100 g tube
Optimoly TA	High-temperature assembly paste	18 21 9 062 599	100 g tube
Silicone grease 300, heavy	Damping grease	07 58 9 058 193	10 g tube
Retinax A	Wheel, steering head and taper roller bearing grease	81 22 9 407 710	100 g tube
Contact spray	Contact spray	81 22 9 400 208	300 ml spray
Sealants			
3-Bond 1209	Surface sealant	07 58 9 062 376	30 g tube
Loctite 574	Surface sealant	81 22 9 407 301	50 ml tube
Curil K 2	Heat-conductive sealant	81 22 9 400 243	250 g can
Hylomar SQ 32 M	Permanently elastic sealant	81 22 9 400 339	100 g tube
Adhesives and retaining agents			
Loctite 648	Surface sealant (narrow gap)	07 58 9 067 732	5 g bottle
Loctite 638	Surface sealant (wide gap)	07 58 9 056 030	10 ml bottle
Loctite 243	Thread retainer, medium-strength	07 58 9 056 031	10 ml bottle
Loctite 270	Thread retainer, strong	81 22 9 400 086	10 ml bottle
Loctite 2701	Thread retainer, strong	33 17 2 331 095	10 ml bottle
Loctite 454	Cyanacrylate adhesive (gel)	07 58 9 062 157	20 g tube
3-Bond 1110 B	Surface sealant	07 58 9 056 998	5 g tube
Cleaners			
Brake cleaner	Brake cleaner	83 11 9 407 848	600 ml spray
Testing agents			
Penetrant MR 68	Crack testing agent for aluminium housings	81 22 9 407 494	500 ml Spray
Developer MR 70	Crack testing agent for aluminium housings	81 22 9 407 495	500 ml spray

Key to maintenance intervals

- Inspection at 1000 km (600 miles)I
- BMW Service at 10,000 km (6000 miles)II
- BMW Inspection at 20,000 km (12,000 miles)III
- BMW Annual Service IV

Changing engine oil

Inspections I, II, III, IV

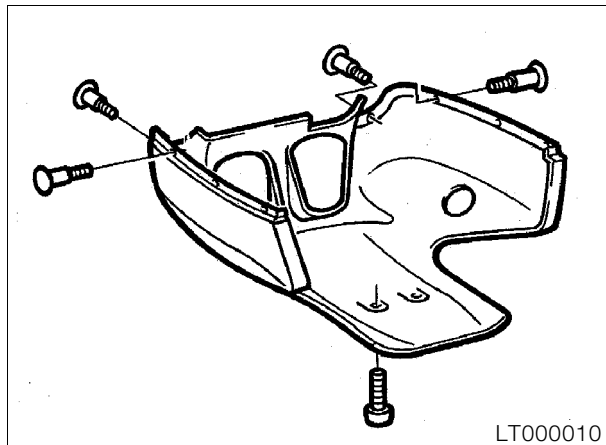

- [RS] Remove lower section of fairing.

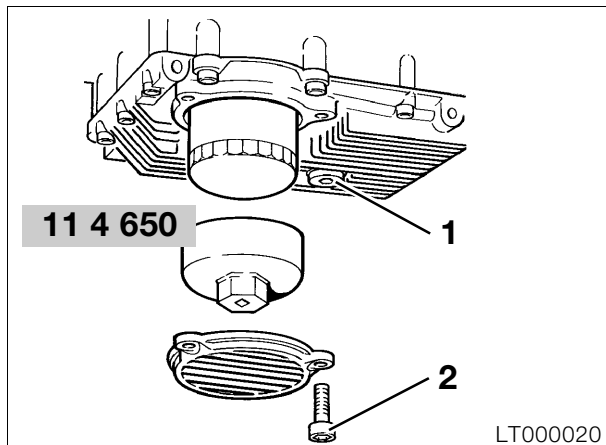

- Change oil at operating temperature.
- Oil drain plug (1).
- Remove oil filter cover retainer (2).
- Unscrew oil filter with special wrench **BMW No. 11 4 650**.



Note:

Coat sealing ring on new oil filter element with oil. Screw in oil filter handtight, take note of hint at filter.

- Replace O-ring in cover, if necessary.



Tightening torques:

Oil drain plug 18 Nm
Cover to oil sump 6 Nm

Quantities:

Oil content 3.50 l (6.16 Imp.pt)
Oil content with filter change 3.75 l (6.6 Imp.pt)
See service data for oil grades Seite 00.3



Changing oil in transmission (gearbox)

Inspections I, III, IV

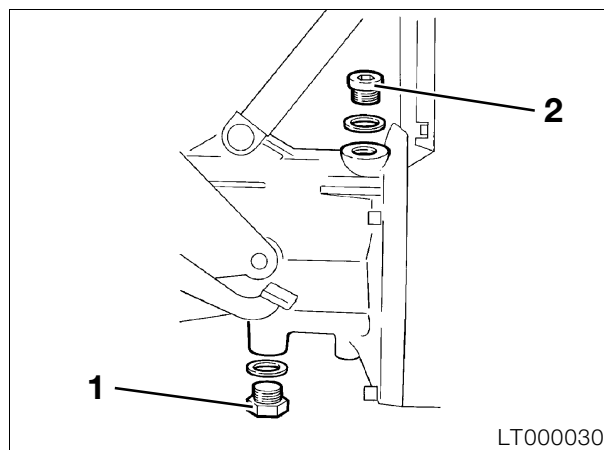

- Drain off oil with engine at operating temperature.
- Oil drain plug (1)
- Oil filler plug (2)



Note:

Renew sealing rings.



Tightening torques:

Oil drain plug 20 Nm
Oil filler plug 20 Nm

Quantities:

Oil filling capacity 0.85 l (1.496 Imp.pt)
See service data for oil grades Page 00.3

Changing oil in rear wheel drive

Inspections I, III, IV

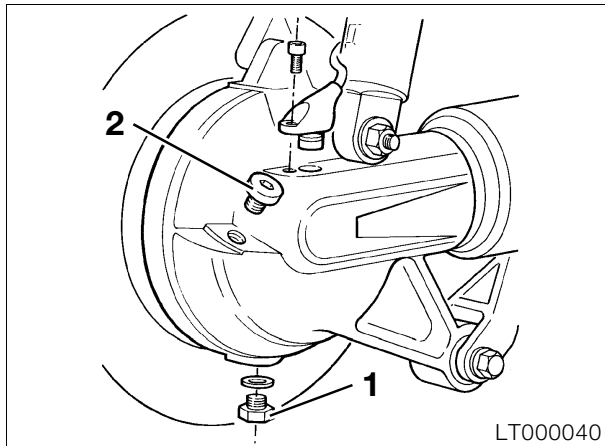

- Drain off oil with drive at operating temperature.
- Oil drain plug (1)
- Oil filler plug (2)



Note:

Fill oil only up to the bottom-most thread turn of the filler hole.

Oil content:

Initial filling 0.25 l (0.44 Imp.pt)

Oil changes 0.35 l (0.616 Imp.pt)

See service data for oil grades Page 00.3



Tightening torques:

Oil filler plug 23 Nm

Oil drain plug 23 Nm

Changing oil in telescopic fork

Inspection I, III, IV

- Support motorcycle on stand.
- Unscrew oil filler plugs.

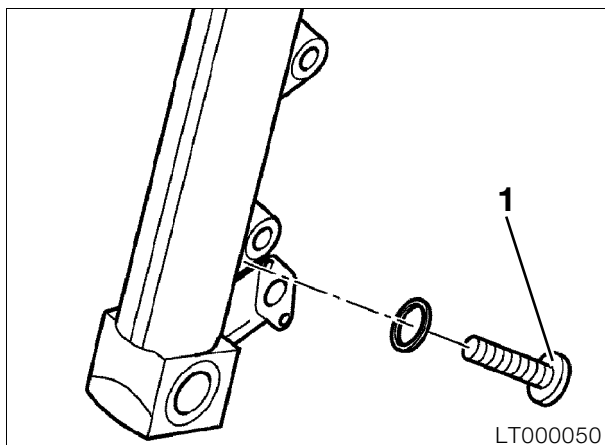

- Release left and right oil drain plug (1).

- Pump out oil by compressing forks several times.
- Screw in oil filler plugs.
- Lift vehicle with lifting gear, **BMW No. 00 1 510**, until the front wheel can move freely.



Note:

The load on the front wheel must be relieved to ensure as much air as possible flows in before the fixed tubes are closed off with the filler plugs so as to provide additional damping.

- Fill with specified quantity of oil.
- Close off fixed tubes.

Quantities:

Oil capacity, left 0.35 - 0.01 l

..... (0.616 - 0.0176 Imp.pt)

Oil capacity, right 0.40 - 0.01 l

..... (0.704 - 0.0176 Imp.pt)

See service data for oil grades Page 00.3



Tightening torque:

Oil filler plugs 20 Nm

Renewing intake air cleaner

Inspection III

- Detach battery panel on right.
- Remove right knee pad.
- Detach right side section of fairing.
- **[LT]** Take off intake air pipe.

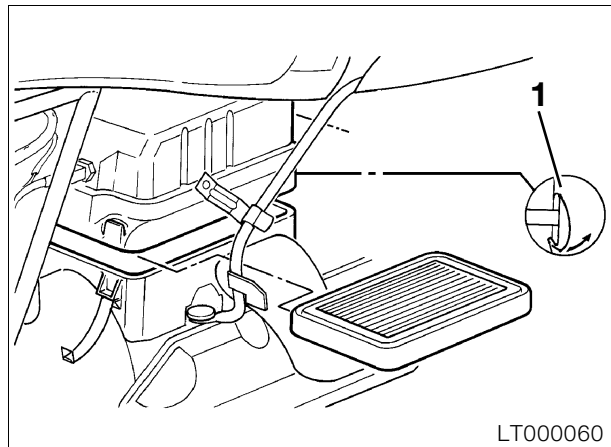

- Release clips (1) at front and rear.
- Slightly raise casing cover, lift out air cleaner.
- Install in the reverse order of removal.



Note:

Note installation position of air cleaner. Lettering at rear, arrow marking "TOP-OBEN".

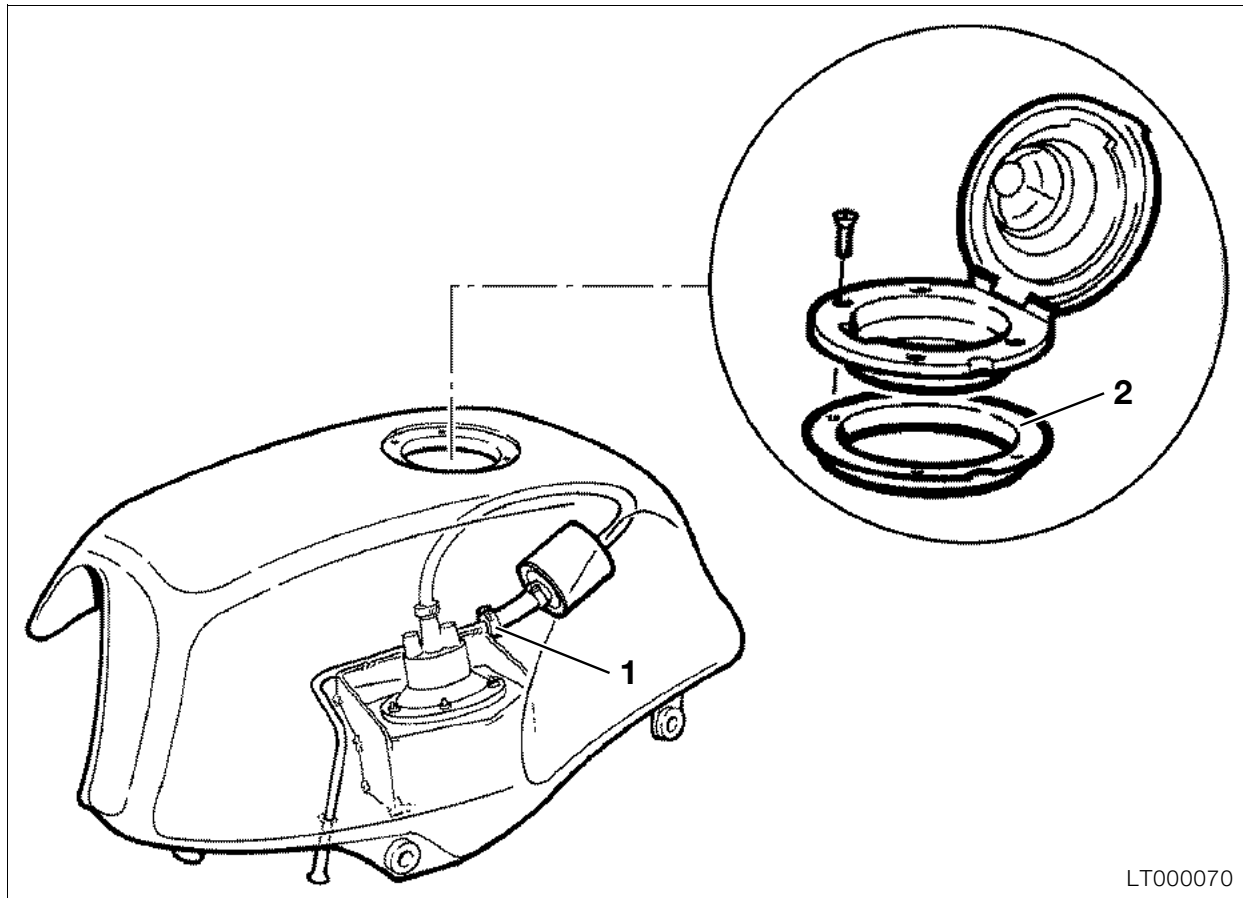

LT000070

Renewing fuel filter

Inspection III

- If necessary, reduce fuel level with pump until filter is clear.
- Loosen hose clip (1) and shift towards filter.
- Detach line and remove filter together with line from the fuel tank.
- Change fuel filter.



Note:

Note direction of fuel flow on filter.

- Reconnect line to pump.
- Install in the reverse order of removal.



Note:

Gasket (2) must not close off the overflow hole. Ensure recesses (arrows) in gasket are fitted in correct position.

Cleaning inductive pulse generator at rear wheel drive

Inspections I, III, IV

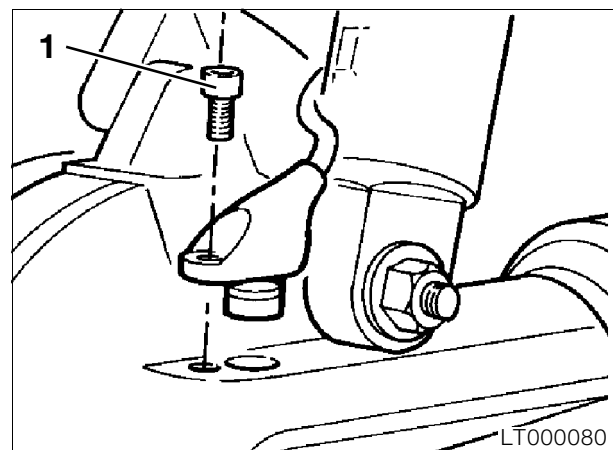

LT000080

- Release securing screw (1).
- If necessary lever out inductive pulse generator and clean with rag.



Tightening torque:

Inductive pulse generator at rear wheel..... 2.5 Nm

Checking brake pads, brake discs for wear and renewing if necessary

Inspection II, III

Front wheel brake

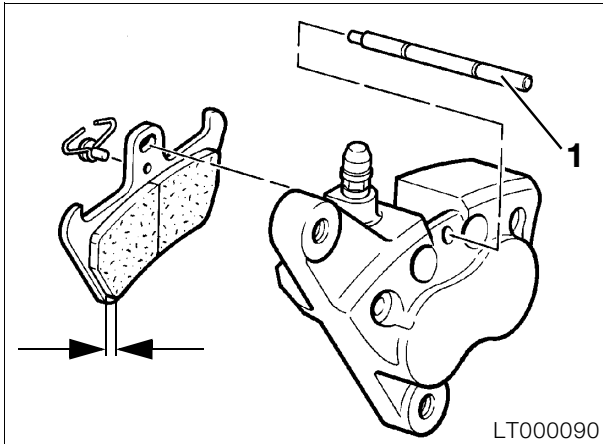

- Remove rear section of mudguard.
- Remove brake caliper.



Note:

It is not necessary to release the brake line at the brake caliper if only the brake pads are to be changed.

- Drive out retaining pin (1).
- Remove brake pads by pulling in downward direction.



Caution:

The brake pad thickness (arrows) must not drop below the minimum specified value. Change pads only as complete sets.

Min. pad thickness on carrier plate.... 1.5 mm (0.06 in)

- Install in the reverse order of removal.

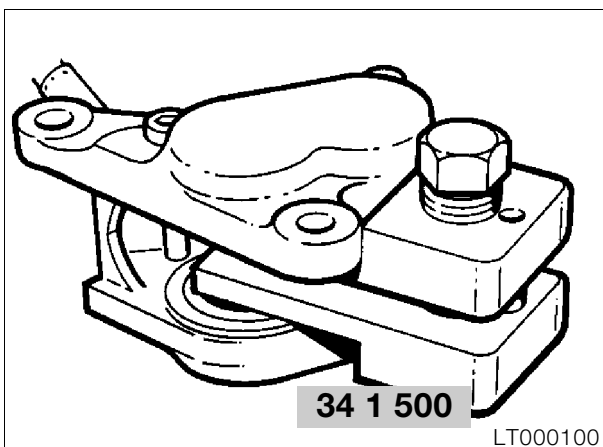

Note:

Before installing the brake caliper, completely press back pistons with resetting tool (1), **BMW No. 34 1 500**.

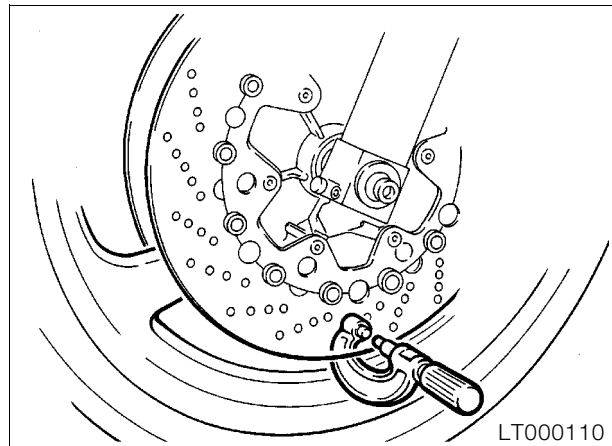

- Measure thickness of brake disc with a micrometer.

Wear limit 4.5 mm

Rear wheel brake

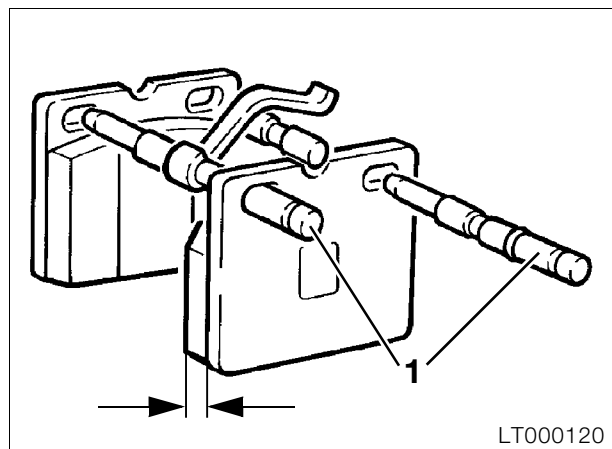

- Lever off cap from brake caliper.
- Remove brake caliper.
- Drive out retaining pins (1) from wheel side.
- Remove brake pads by pulling upward.
- Install in the reverse order of removal.

Minimum pad thickness on carrier plate..... 1.5 mm
..... (0.06 in)

Wear limit of brake disc 4.5 mm
..... (0.177 in)

Checking brake fluid level and correcting if necessary

Inspections I, II, III

Checking brake fluid level

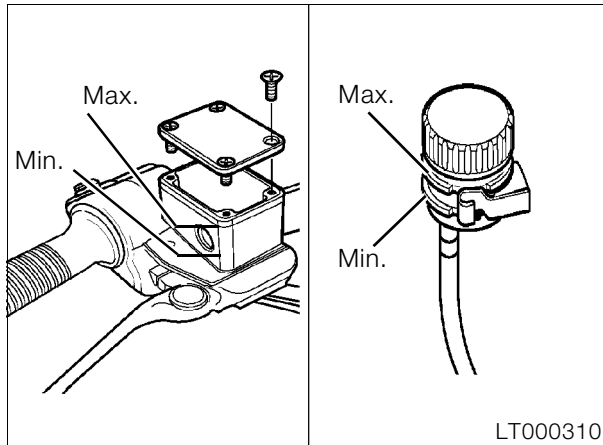

Note:

When checking front brake fluid level, the cover of the brake fluid reservoir must always be horizontal (see SI 00 027 95 (716)).

Adding brake fluid

- Take off the reservoir cover together with the diaphragm



Note:

When adding brake fluid, note the remaining brake pad thickness. If the brake pads are new, add fluid up to the MAX mark.

- Add brake fluid.
- Replace the diaphragm and reservoir cover in position.
- Tighten the retaining screws without using undue force.

Brake fluid grade:

Use only brake fluid in quality category DOT 4 (e.g. ATE "SL" brake fluid).

Checking brake system

Inspection III

- Check all brake lines for damage and ensure they are fitted in the correct position.
- Wipe clean all screw connections of the brake lines.
- Operate brake with force and hold for a short space of time at this point. Then inspect brake lines for any leakage points.

Checking ABS sensor spacing and adjusting if necessary

Inspections I, II, III

Front sensor

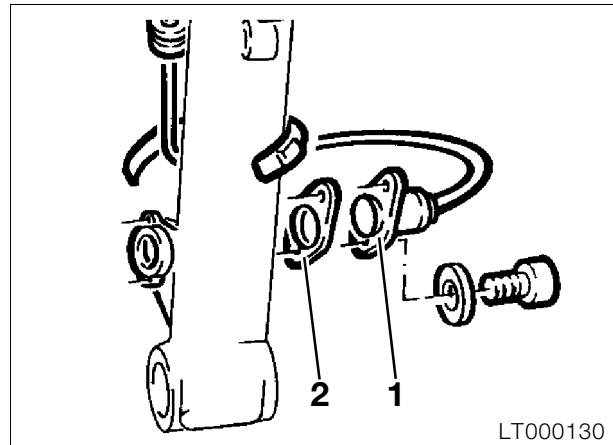

- Check sensor spacing with feeler gauge.

Sensor spacing 0.50 ... 0.55 mm
..... (0.0197...0.0217 in)

- To adjust, release sensor (1) and set spacing with spacer plates (shims) (2).

Rear sensor

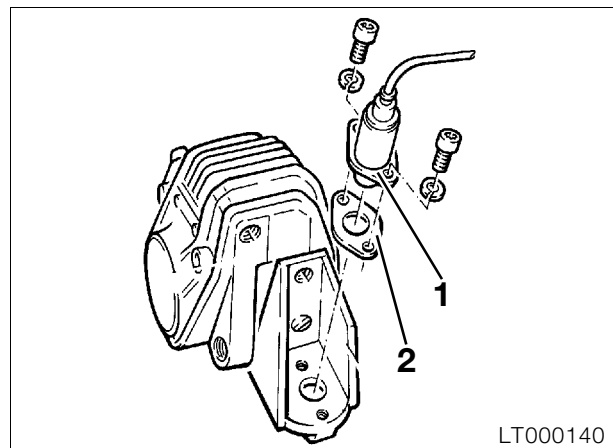

- Check sensor spacing with feeler gauge.

Sensor spacing 0.60 ... 0.65 mm
..... (0.0236...0.0256 in)

- To adjust, release sensor (1) and set spacing with spacer plates (shims) (2).



Renewing brake fluid

Renewing front brake fluid

- Remove the brake pads



Caution:

Do not tilt the brake caliper when removing or installing, or the brake pads could be damaged.

- Take off the brake fluid reservoir cover complete with the diaphragm.
- Add brake fluid.



Caution:

While renewing the brake fluid, its level must not drop below the MIN mark, or else air will be drawn into the brake circuit.

If this happens, the brake system will have to be bled.

- Connect a suitable vessel to the bled screws on the brake caliper to trap the escaping brake fluid, and open the bleed screw by half a turn.

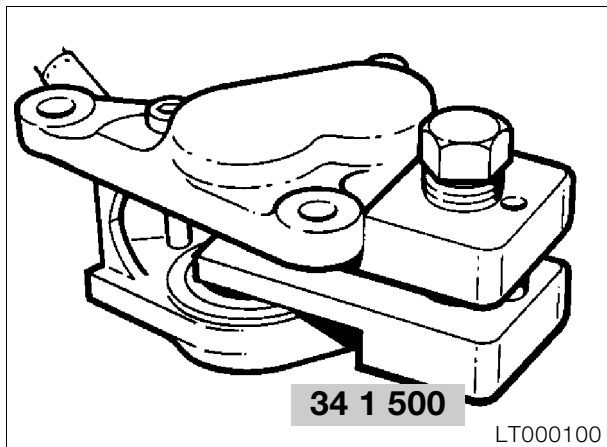

- Using piston resetting tool, **BMW No. 34 1 500**, press the pistons fully back into the brake calipers.
- Take out the piston resetting tool and insert spacer, **BMW No. 34 1 520**.
- Press the pistons back in the second brake caliper, but do not remove the piston resetting tool.
- Close the bleed screw.
- Apply the handbrake lever several times until braking pressure is felt to build up.

- **Hold the handbrake lever in to maintain the braking pressure and open the bleed screw, at the same time pulling the handbrake lever up firmly.**



Caution:

Do not release the handbrake lever until the bleed screw has been closed.

- Close the bleed screw, then release the handbrake lever.
- Allow brake fluid to escape from both brake calipers in succession until it is clear and free from air bubbles.
- Close the bleed screw.
- Install the brake pads/brake calipers.



Note:

When adding brake fluid, note the thickness of the brake pads. If the pads are new, add fluid up to the MAX mark.

- Brake fluid level = Max mark.
- Place the diaphragm and reservoir cover back in position.
- Tighten the retaining screws without using undue force.
- Make a functional check on the brakes and bleed the brake system if necessary.

Renewing rear brake fluid

- The rear brake caliper does not have to be removed, nor its pistons forced back.
- Continue the procedure as described for front brake fluid renewal.



Caution:

Do not release the brake pedal until the bleed screws have been closed.

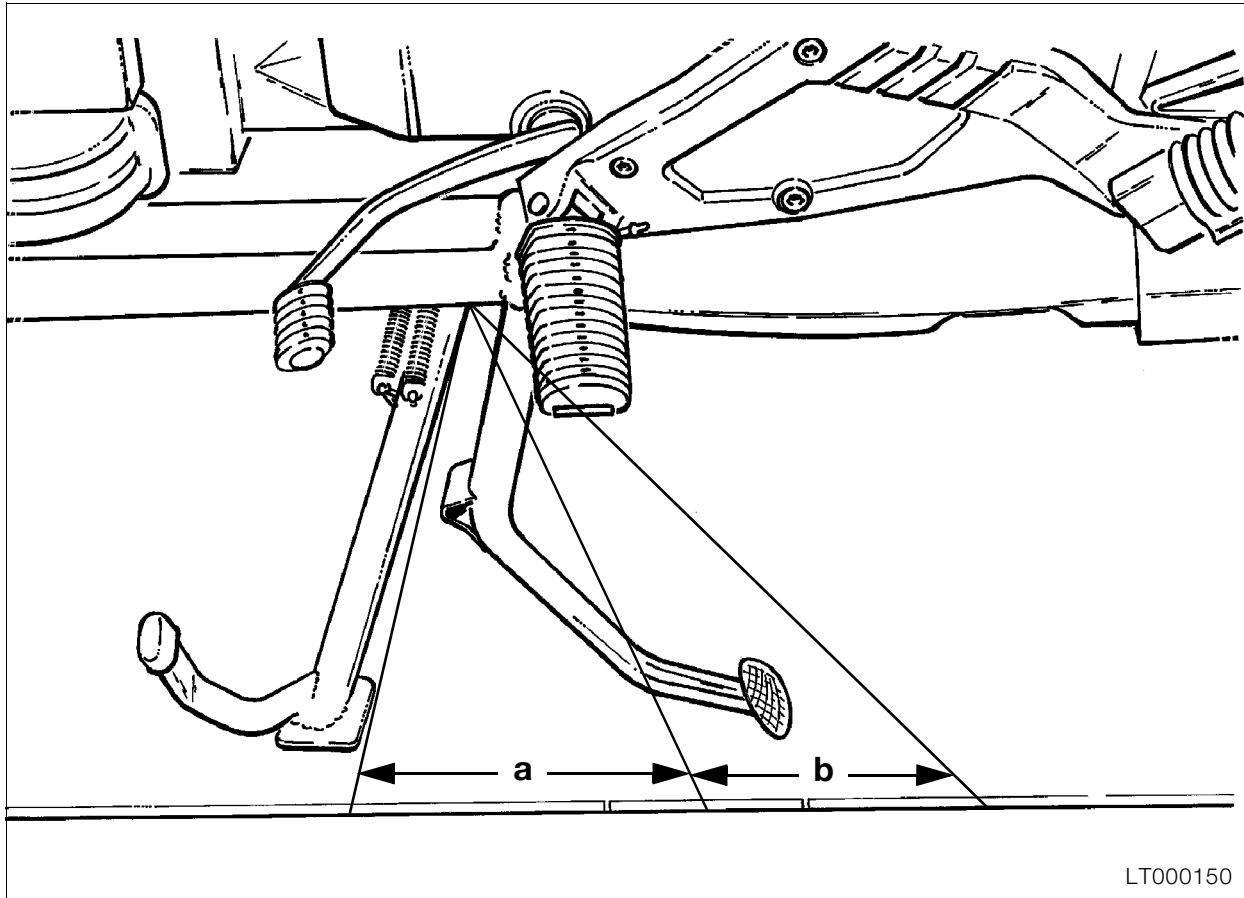

LT000150

Checking function of electric switch on side stand and adjusting if necessary

Inspections I, II, III

- Place motorcycle on centre stand on even surface or lifting platform.
- Spray switching kinematics of the side stand with quick-action cleaner and fold in and out several times.
- Completely fold out side stand and mark position on ground surface.
- Make a second marking at distance "a" and a third marking at distance "b".

Distances:

"a"..... 95 mm (3.74 in)
 "b"..... 50 mm (1.97 in)

- Fold in side stand and start engine.
- Slowly fold out side stand, the engine must stall in the area of dimension "b".
- If the engine does not stall, the switch must be checked and replaced if necessary.

Caution:

Bending the contact spring can result in malfunctioning of the switch.

Therefore:

Never bend the contact spring!

- Operate starter while slowly folding in the side stand; the engine must start up in area "b".
- If the engine does not start up or if the side stand is difficult to move, check the switch or disassemble the side stand.

Checking clutch clearance and adjusting if necessary

Inspections I, III

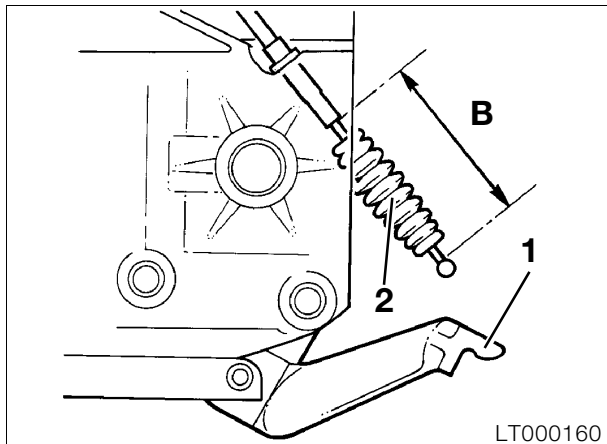

- Detach clutch cable at clutch release lever (1).
- Slightly push back rubber sleeve (2).
- With the aid of setting gauge, **BMW No. 21 3 500**, set dimension "b" with adjusting screw at clutch hand lever.

Dimension " B " 75 ± 1 mm (2.952 ± 0.03937 in)

- Reattach clutch cable at clutch release lever.

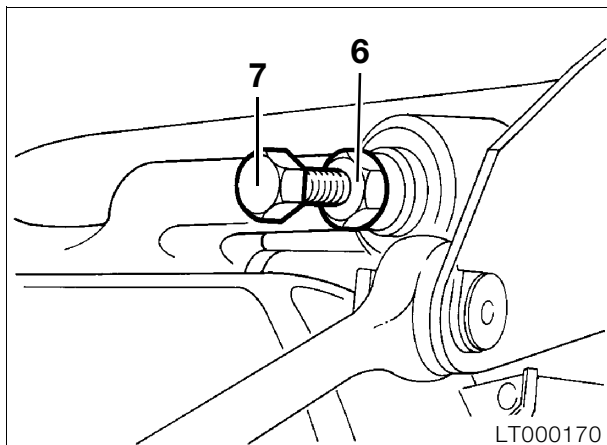

- Using box spanner, **BMW No. 21 3 610**, release locknut (6) of adjusting screw (7) at clutch release lever.
- Unscrew adjusting screw by one to two turns, then screw in until pressure can be felt.
- Lock adjusting screw with locknut.

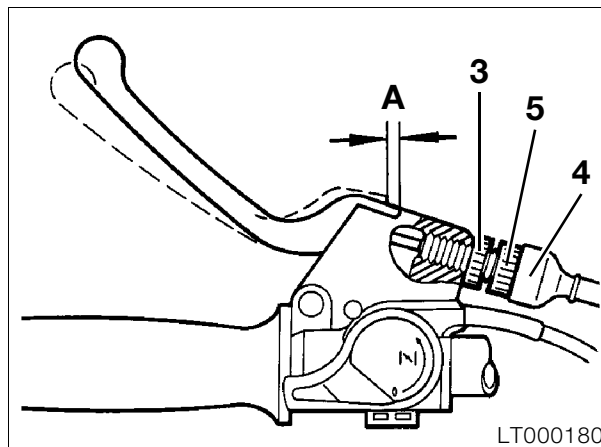

- Set dimension "A" with adjusting screw at clutch hand lever.
- Lock adjusting screw (5) with knurled nut (3).

Dimension "A" 4 ± 0.5 mm (0.157 ± 0.0197 in)



Caution:

Adjust to take up wear only at the adjusting screw on the clutch release lever.

Reading out Motronic defect code memory

Inspections II, III

- Carry out this job only on motorcycles with catalytic converter.



Note:

To read out Motronic defect code memory, see the booklet entitled:
"BMW Diagnosis, Motronic 2.1 with oxygen-sensor control" (order No. 01 70 9 798 970).

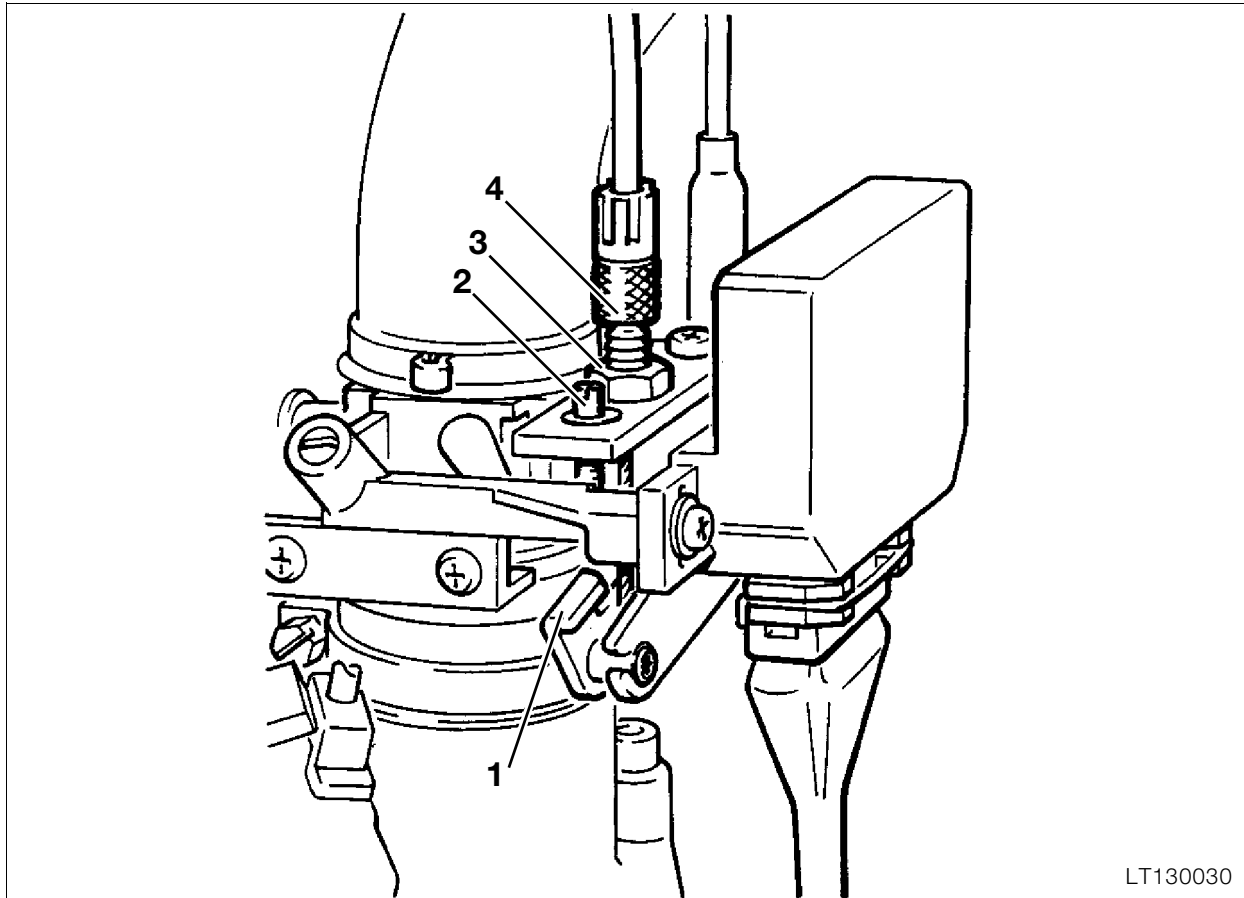

LT130030

Checking increased starting speed (choke) and adjusting if necessary

Inspections I, III

Checking increased starting speed

- Remove the left battery cover.
- Move the increased starting speed device up to its limit stop (stage 2).



Caution:

Screw (2) is secured with lacquer and must not be reset.



Note:

Stop face (1) must make contact with screw (2) and the wire cable must have zero play; failing this, cable play must be adjusted.

- Check stop face (1).
- Move the increased starting speed device up to its limit stop (stage 2).
- Loosen locknut (3).
- Press the lever with stop face (1) against screw (2).
- Turn adjusting screw (4) to obtain zero play in the cable.
- Tighten locknut (3).

Checking valve clearance and adjusting if necessary

Inspections I, III



Caution:

Never unscrew the spark plugs before measuring the valve clearance. Carbon particles may settle behind an exhaust valve head and falsify the measured result.

- [RS] Remove bottom section of fairing .
- Remove left side section of fairing.
- Remove cylinder head cover.
- Remove cover for Hall generator.
- Only crank engine at the crankshaft (counter-clockwise!).
- Measure valve clearance with feeler gauge.
- Max. engine temperature 35 °C.
- Determine the replacement tappet by way of nominal/actual value comparison.

Valve clearance:

Inlet0.15 - 0.20 mm (0.0059 - 0.0079 in)
 Exhaust0.25 - 0.30 mm (0.0098 - 0.0118 in)

Adjusting valve clearance

- The camshafts must be removed in order to change the bucket tappets.
- Set cylinder No. 1 (timing end) to ignition TDC.

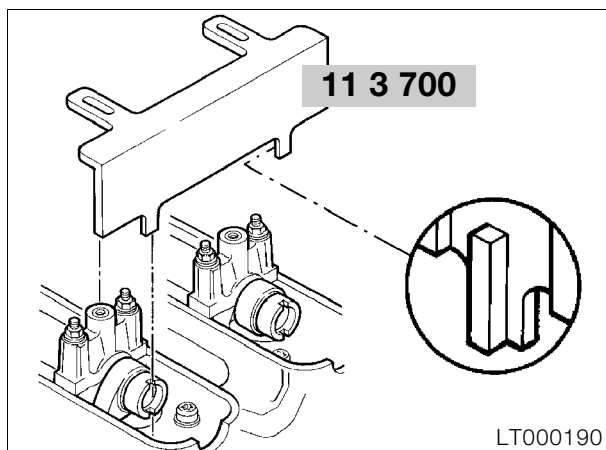

- The setting device for the camshafts, **BMW No. 11 3 700**, must fit in the slots at the ends of the shafts.
- Unscrew screw plug in chain case cover.

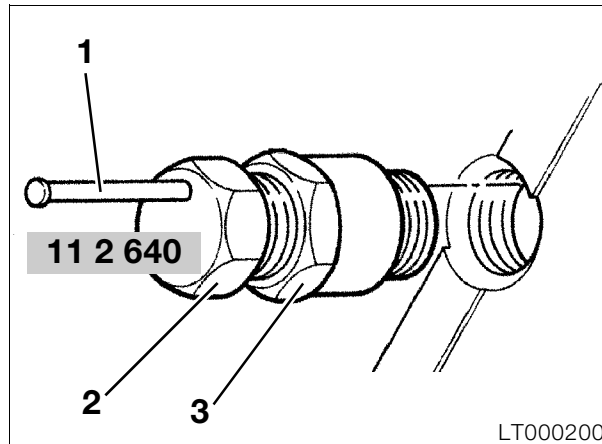

- Lock chain tensioner and timing chain in position with eccentric tensioner, **BMW No. 11 2 640**.
- Pull back clamping pin (1), screw in eccentric pin (2) by 3-4 turns.
- Push in clamping pin above the timing chain.
- Fix timing chain and chain tensioner in position by slightly turning eccentric pin in clockwise direction.
- Secure eccentric pin with locknut (3).

Removing sprockets

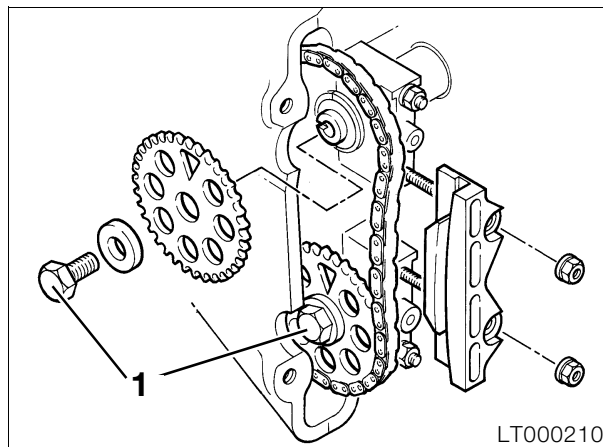

- Release retaining bolts of sprockets and remove sprockets.

Removing camshafts

- Remove chain guide from stud bolt.
- First remove thrust bearing of camshafts to avoid misalignment.
- Remove remaining camshaft bearings and lift out camshaft.
- Remove bucket tappets to be changed with relay pliers **BMW No. 61 1 250**, or a magnet.



Note:

Only the bucket tappets replaced during the 1000 km (600 miles) inspection can be re-used.

Installing camshafts

- The camshafts are marked to ensure they cannot be confused.



Caution:

Camshaft identification.

Inlet: Groove after the thrust bearing

Exhaust: No groove

- The camshaft bearing caps are also identified.
Inlet side: Odd numbers
Exhaust side: Even numbers
- The order is ascending from the front (timing end) to the rear.
- Install camshafts with the bearing points slightly oiled.
- Evenly tighten bearing cap working from the inside towards the outside.
- Install thrust bearing (timing end) last.



Tightening torque:

Bearing cap..... 9 Nm

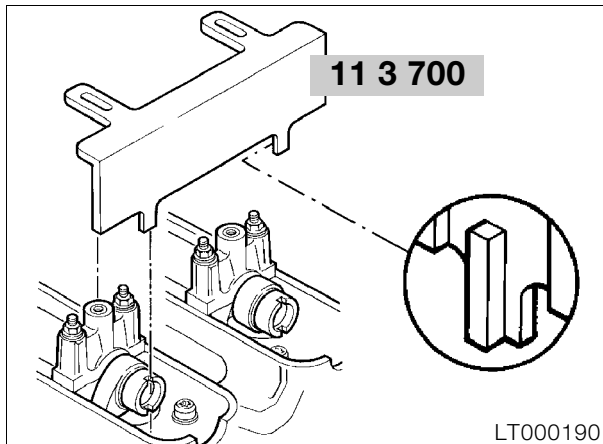

- Turn camshafts so that the grooves at the rear ends are positioned vertically with respect to the cylinder head.
- The grooves at the front end must face the inside towards the crankshaft.
- Fit setting device, **BMW No. 11 3 700**, and secure to the bearings of the camshaft.

Installing sprockets

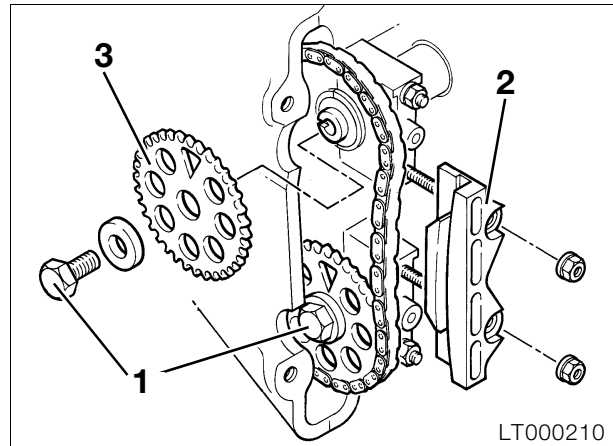

- Install lower sprocket (1) together with chain and chain guide (2); the pin on the sprocket must engage in the groove on the camshaft.
- When installed, the marking (triangle) on the sprocket must face upward.
- Then install the upper sprocket (3) with chain.
- Initially, only tighten sprocket retaining bolts hand-tight.



Caution:

Remove setting device before finally tightening the sprockets, otherwise the camshafts will be damaged.

- Remove eccentric tensioner.
- Firmly tighten sprockets while holding at the hexagon on the camshaft.



Tightening torque:

Sprocket to camshaft..... 54 Nm

- Check valve clearance once again.

Installing cylinder head cover

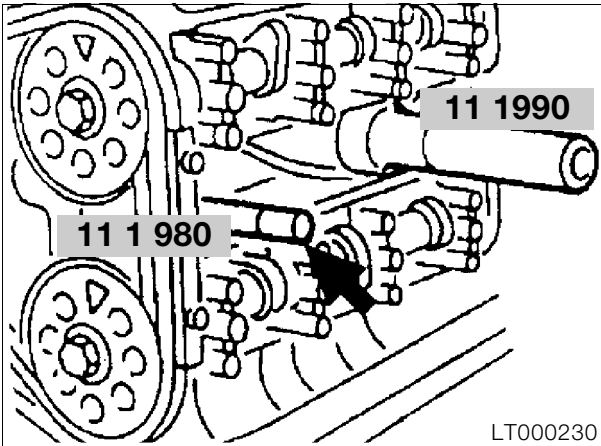

- Fit cylinder head cover with gasket over the centring tools onto the cylinder head.
- Screw in all retaining bolts such that they are still not under preload.
- Firmly tighten retaining bolts crosswise working from the inside towards the outside.
- Remove fitted bolt and centring pin, screw in last retaining bolt and firmly tighten.

Tightening torque:

Cylinder head cover to cylinder head 9 Nm

- Screw fitted bolt, **BMW No. 11 1 980**, (arrow) into inner hole at the front.
- Press centring pin, **BMW No. 11 1 990**, with gripper, **BMW No. 00 5 500**, into locating hole under the third camshaft bearing.

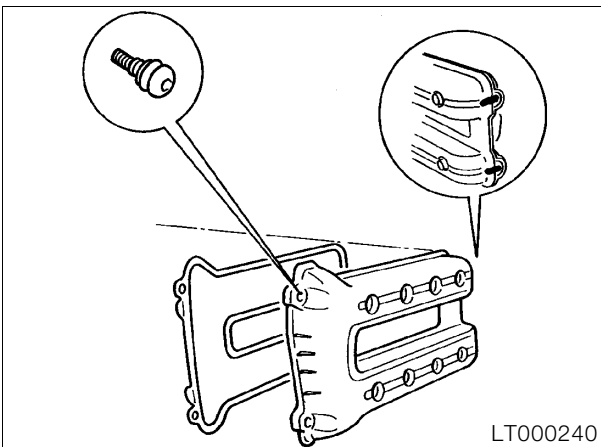

- Insert gasket into cylinder head cover.



Note:

Begin installation at the crescents (1).

- The marks (arrows) on the cover and gasket must agree at the front and rear.
- First press in the crescent at the rear (transmission end).
- Lightly coat the gasket groove and the crescent areas in the cover with oil to facilitate installation.
- Apply a little **3-bond 1209** in the joint area at the top and bottom chain case cover - cylinder head (surfaces free of grease).

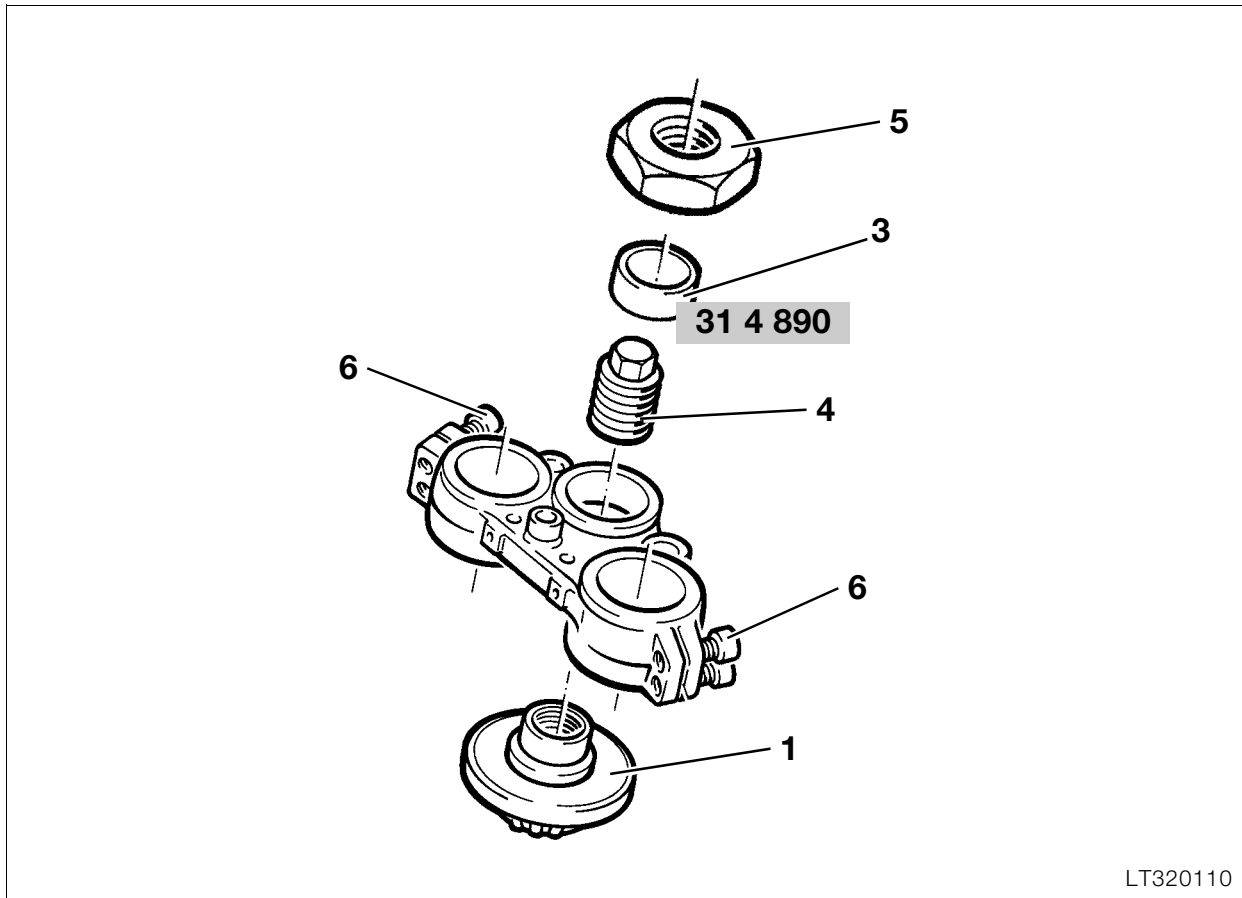

LT320110

Checking steering bearing play and adjusting if necessary

Inspection III

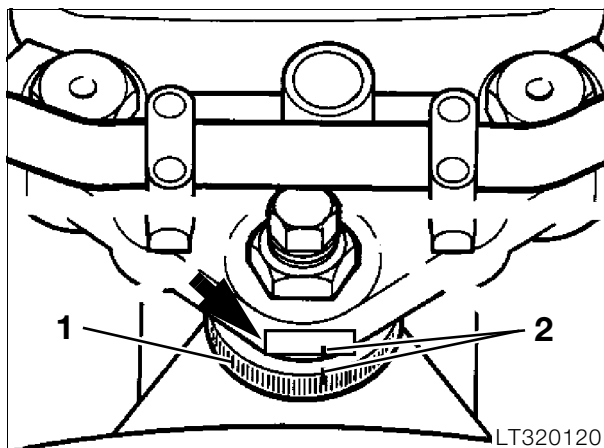

- Place a piece of adhesive tape (arrow) on the fork bridge above the setting ring (1).
- Mark current position of setting ring (1) on the adhesive tape and on the setting ring (2).
- Slide thrust ring (3), **BMW No. 31 4 890**, over the locking tube (4).
- Lock thrust ring with hexagon nut (5) while holding the locking tube.
- Using the hexagon nut, turn back the setting ring a little then firmly tighten to the specified setting torque.

Setting torque:

Hexagon nut 12 Nm

New bearing:

Pretighten hexagon nut to 25 Nm

Move steering several times from stop to stop, loosen hexagon nut and retighten 12 Nm

- Mark new position of setting ring on adhesive tape.
- Loosen hexagon nut and remove thrust ring.
- Firmly tighten locking tube, firmly tighten hexagon nut.



Note:

The position of the setting ring must no longer change!

- The position of the setting ring must no longer change!
- Firmly tighten clamping screws.



Tightening torque:

Locking tube 65 Nm

Hexagon nut 65 Nm

Clamping screws of fork bridge (6) 15 Nm

Clamping block for handlebar 22 Nm

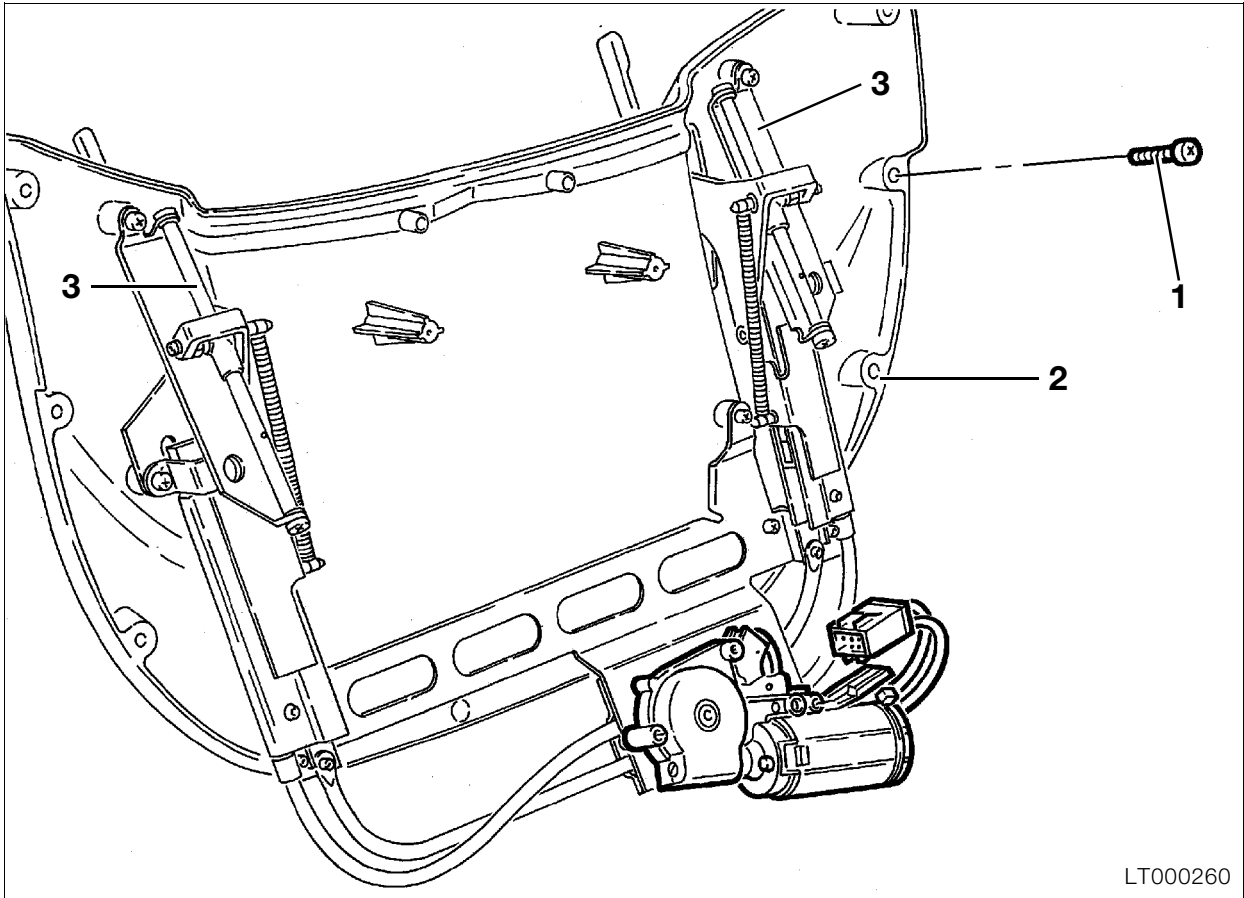

LT000260

Lubricating guide pins, adjustable screen

Inspections III, IV

- Release retaining screw (1) on both sides.
- Slightly raise plate (2).
- Spray guide pins (3) with silicone spray.

Checking idle speed, synchronising and CO value and adjusting if necessary

Inspections I, II, III, IV



Note:

The basic settings (ignition, valve clearance) must be correct.

Adjusting idle speed

- Remove knee pad.
- Remove left side section of fairing.

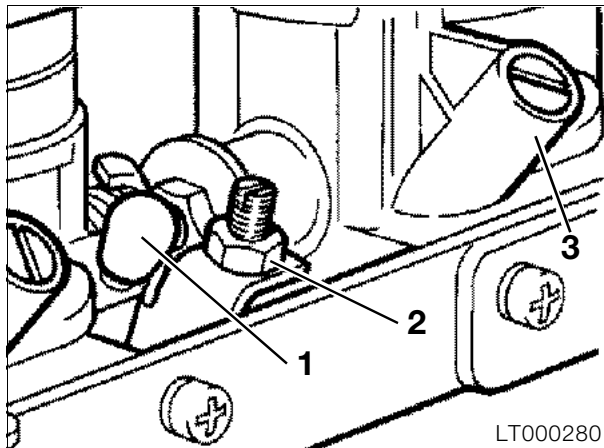

- Remove caps (1) at the vacuum connections.
- Connect hoses of the synchrotester, **BMW No. 13 0 800**, in the specified order (note markings 1 - 4 on tester housing).
- Connect tester to motorcycle's power socket with the corresponding adapter lead.
- Start engine and allow to run for app. 10 minutes if not already warm.



Caution:

Max. idling time at a standstill = 20 minutes.

- Run the engine at idle speed.
- Select "bar diagram" display with maximum resolution.



Note:

If the differences between the individual bars (columns) is very large (more than 2 - 5 mm) switch over to curve display and compare the individual cylinders with each other; perform defect diagnosis if necessary.

- Rectify defects.



Caution:

The throttle butterfly adjusting screws (2) are sealed with lacquer and must not be turned.

- Adjust synchronisation at idle speed by turning the air control screws (3) until the bars/curves are at the same height, then adjust idle speed.

Idle speed..... 950 ± 50 rpm



Adjusting CO value without catalytic converter

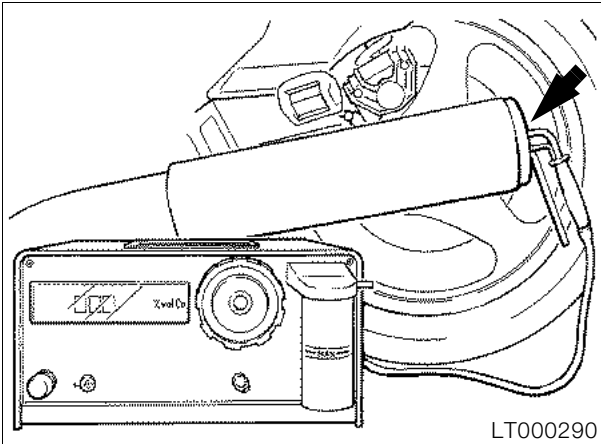

Note:

Engine must be at operating temperature (85 °C). The basic settings (ignition, valve clearance) must be correct.

- Insert test probe (arrow) approx. 30 cm into the silencer.

Caution:

Do not take this measurement in an enclosed space; risk of asphyxiation.

Note:

If unsuitable air extraction equipment is used, it may falsify the reading.

- Run the engine at idle speed.

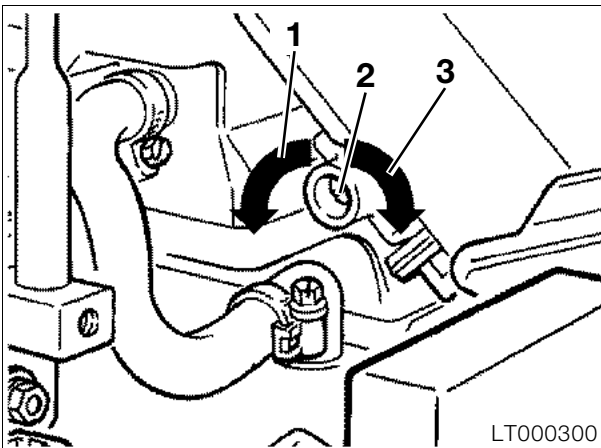

Caution:

Adjusting screw (2) has no limit stop in both directions.

- Turn adjusting screw (2) to vary the CO value.

Note:

Turn in direction (1) for a richer mixture; the CO value will rise towards its maximum value. Turning further in direction (1) will not vary the CO value any further. Turn in direction (3) for a leaner mixture; the CO value will drop to a minimum. Turning further in direction (3) causes the engine's emergency-run programme to operate and has no influence on the CO value.

Caution:

If the engine's emergency-run programme comes into operation, fault 1111 will be memorised by the engine control unit.

- If necessary, perform fault diagnosis, rectify the fault and cancel the memory entry.
- Using the BMW synchrotester, adjust idle speed at the recirculating-air screws.

CO value 1.5 ± 0.5 Vol. %
 Idle speed 950 ± 50 rpm

11 Motor

Contents

Page

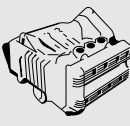

Technical data	5
Removing engine	11
Dismantling engine	12
Removing intermediate flange	13
Removing driver	13
Removing clutch housing	14
Stripping down and re-assembling intermediate flange	15
Removing the driver bearing	15
Installing driver bearing	15
Removing and installing shaft sealing ring for driver	16
Removing countershaft and layshaft with freewheel	16
Dismantling and assembling freewheel	17
Stripping down freewheel	17
Assembling freewheel	17
Removing and installing layshaft needle roller bearing	18
Removing bearing	18
Installing bearing	18
Removing timing chain cover	19
Removing the Hall-effect signal transmitter	19
Remove the crankshaft cover	19
Removing cylinder head cover	19
Removing and installing sealing ring in timing case cover	19
Removing the timing chain	20
Removing chain tensioner	20
Removing chain tensioner rail	20
Renewing chain tensioner rail facing	20
Removing camshaft chain sprockets	21
Removing chain guide	21
Removing, stripping down and assembling cylinder head	22
Removing camshafts	22
Removing cylinder head	22
Removing bucket-type tappets	22
Removing valves	23
Remachining valve seat	23
Installing valve and valve stem seal	24
Removing crankshaft	25
Removing big end bearings	25
Removing main bearings	25

Removing pistons with conrods, stripping down and re-assembling	26
Removing piston with conrod	26
Dismantling piston	26
Checking piston dimensions	26
Assembling pistons	27
Checking cylinder dimensions	27
Removing and installing small-end bushing	27
Assembling pistons and conrods	28
Removing and installing crankshaft pinion and rotor flange	28
Removing, dismantling and assembling combined oil-water pump	29
Removing pump	29
Dismantling pump	29
Removing slipring seal and shaft sealing ring	30
Removing pressure relief valve	30
Installing pressure relief valve	30
Install the shaft sealing ring and slipring seal	30
Installing pump shaft and impeller	30
Removing output shaft	31
Removing oil sump	31
Removing oil filter	31
Removing lower section of crankcase	31
Removing and installing oil level sight glass	31
Stripping and assembling output shaft	32
Stripping down output shaft	32
Stripping down tensioning gear	32
Assembling tensioning gear	33
Installing damper	33
Assembling engine	34
Installing output shaft	34
Assembling the crankcase	35
Installing oil mesh strainer	35
Installing oil filter	35
Installing oil sump	35
Measuring crankshaft bearing play	36
Measuring radial play	36
Measuring endplay	37
Checking dimensions of crankshaft	37
Installing crankshaft	38
Installing piston with conrod	39
Measuring big end bearing play	40
Installing big end bearing	40
Installing combined oil-water pump	41
Installing cylinder head	42
Installing camshafts	43

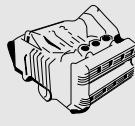

Contents

Page

- Installing timing chain44
- Checking valve clearances45
- Installing intermediate flange46
 - Installing freewheel46
 - Installing countershaft46
 - Installing intermediate flange46
- Installing driver46
- Installing alternator46
- Installing timing case cover47
- Installing hall-effect transmitter47
- Installing cover for Hall-effect transmitter48
- Installing cylinder head cover49
- Installing engine50**
- Checking/adjusting valve clearances52**
- Adjusting valve clearances52

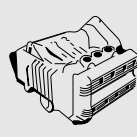

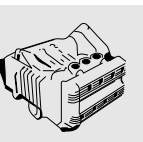

Technical data	K 1100 LT	K 1100 RS
Engine, general		
Engine design	Inline four-stroke engine installed longitudinally, with double overhead camshafts, liquid cooling and electronic fuel injection.	
Location of engine number	At lower rear right of engine block	
Cylinder bore	mm (in)	70.5 (2.77)
Stroke	mm (in)	70 (2.75)
Number of cylinders	4	
Effective displacement	cc	1093
Compression ratio	11.0 : 1	
Power output	kW (hp)	74 (100) at 7500 min ⁻¹
Max. torque	Nm	107 at 5500 min ⁻¹
Permissible maximum engine speed	min ⁻¹	8900
Permissible continuous engine speed	min ⁻¹	8500
Idle speed	min ⁻¹	950 ⁺⁵⁰
Direction of rotation	Anti-clockwise. looking at ignition system	
Compression test pressure	bar (psi)	
good		above 10.0 (142.3)
normal		8.5...10.0 (120.9...142.3)
poor		below 8.5 (120.9)
Engine lubrication	Pressurised oil circuit	
Oil filter	Full-flow type	
Difference for opening bypass valve	bar (psi)	1.5 (21.3)
Oil pressure warning light comes on below	bar (psi)	0.2...0.5 (2.8...7.1)
Pressure relief valve opens at	bar (psi)	5.4 (76.8)
Oil content		
without filter change	l	3.50 (6.2 Imp. pints)
with filter change	l	3.75 (6.6 Imp. pints)
Permissible oil consumption	l/100km (mile/gal)	0.15 (1,875)
Oil pump	Gear-type	



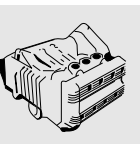

Technical data		K 1100 LT	K 1100 RS
Valves			
Valve clearances with engine cold (max. 35 °C)			
Inlet valve	mm (in)	0.15...0.20 (0.0059...0.0079)	
Exhaust valve	mm (in)	0.25...0.30 (0.0098...0.0118)	
Valve timing		at 5/100 mm (0.002 in) preload and 3 mm (0.118 in) lift	
Inlet opens		14° after TDC	
Inlet closes		18° after BDC	
Exhaust opens		18° before BDC	
Exhaust closes		14° before TDC	
Valve length			
Inlet	mm (in)	115.1 (4.531)	
Exhaust	mm (in)	113.7 (4.476)	
Valve head dia.			
Inlet	mm (in)	26.45 (1.041)	
Exhaust	mm (in)	22.95 (0.886)	
Stem dia.			
Inlet	mm (in)	5.96...5.975 (0.2346...0.2352)	
Wear limit	mm (in)	5.94 (0.2339)	
Exhaust	mm (in)	5.945...5.96 (0.2341...0.2346)	
Wear limit	mm (in)	5.925 (0.2333)	
Valve head edge thickness			
Inlet	mm (in)	1.04 (0.041)	
Exhaust	mm (in)	1.09 (0.043)	
Max. valve head runout			
Inlet, exhaust	mm (in)	0.02 (0.0008)	
Valve seat angle			
Inlet, exhaust		44° 30'...20'	
Valve seat width			
Inlet	mm (in)	1.1 (0.043) ± 0.15 (0.006)	
Wear limit	mm (in)	2.5 (0.098)	
Exhaust	mm (in)	1.3 (0.051) ± 0.15 (0.006)	
Wear limit	mm (in)	3.0 (0.118)	
Length of valve guide			
Inlet	mm (in)	45 (1.772)	
Exhaust	mm (in)	57.5 (2.264)	

Technical data		K 1100 LT	K 1100 RS
Valves			
Valve guide dia.			
Extl. dia.	mm (in)	11.533...11.544 (0.4541...0.4545)	
Intl. dia.	mm (in)	6.0...6.012 (0.2362...0.2367)	
Wear limit	mm (in)	6.1 (0.2402)	
Bore in cylinder head	mm (in)	11.5...11.518 (0.4528...0.4535)	
Repair stage	mm (in)	11.7...11.718 (0.4606...0.4613)	
Valve stem clearance			
Inlet	mm (in)	0.025...0.052 (0.001...0.002)	
Exhaust	mm (in)	0.040...0.067 (0.0016...0.0026)	
Valve spring			
Extl. dia.	mm (in)	21.6 (0.8504) ± 0.2 (0.0079)	
Wire dia.	mm (in)	3.2 (0.126)	
Spring length, off-load	mm (in)	41.1 (1.618)	
Wear limit	mm (in)	39.6 (1.559)	
Winding direction		clockwise	
Number of effective windings		3.8...6	
Total number of windings		7.8	
Camshaft			
Inlet camshaft	°	284	
Exhaust camshaft	°	284	
Guide bearing dia.	mm (in)	29.970...24.0 (1.180...0.945)	
Wear limit	mm (in)	29.95 (1.179)	
Guide bearing bore	mm (in)	30.02...30.041 (1.1819...1.1827)	
Camshaft bearing bore	mm (in)	24.02...24.041 (0.945...0.9465)	
Radial clearance			
Guide bearing	mm (in)	0.020...0.071 (0.0008...0.0028)	
Camshaft bearing	mm (in)	0.020...0.071 (0.0008...0.0028)	
Cam base circle dia.	mm (in)	30 (1.181)	
Cam height, inlet and exhaust	mm (in)	38.855 (1.5297) ± 0.031 (0.0012)	
Wear limit	mm (in)	38.550 (1.5177)	
Tappets			
Extl. dia.	mm (in)	26.853...26.840 (1.0572...1.0567)	
Wear limit	mm (in)	25.970 (1.0224)	
Bore in cylinder head	mm (in)	26.065...26.086 (1.0262...1.0270)	
Wear limit	mm (in)	26.170 (1.0303)	
Radial clearance	mm (in)	0.072...0.106 (0.0028...0.0042)	
Wear limit	mm (in)	0.200 (0.0079)	
Timing chain			
Single roller chain, endless, pre-stretched, with 126 links			





Technical data			K 1100 LT	K 1100 RS
Crankshaft				
Main bearing and crankpin markings			Grinding stage 0	
no colour spot			Grinding stage 1	
with colour spot				
Width of guide bearing	mm (in)	23.020...23.053 (0.9063...0.9076)		
Axial play	mm (in)	0.080...0.183 (0.0031...0.0072)		
Wear limit	mm (in)	0.250 (0.010)		
Main bearing dia.				
	Grinding stage 0	mm (in)	44.976...45.000 (1.7707...1.7716)	
	Grinding stage 1	mm (in)	44.726...44.750 (1.7609...1.7618)	
Main bearing radial play	mm (in)	0.020...0.056 (0.0008...0.0022)		
Wear limit	mm (in)	0.130 (0.0051)		
Main bearing bore dia.	mm (in)	49.00...49.14 (1.929...1.935)		
Crankpin dia.				
	Grinding stage 0	mm (in)	37.976...38.000 (1.4951...1.4961)	
	Grinding stage 1	mm (in)	37.726...37.750 (1.4853...1.4862)	
Big end bearing width	mm (in)	21.810...22.065 (0.8587...0.8687)		
Connecting rod				
Small end bore dia.	mm (in)	41.000...41.016 (1.6142...1.6148)		
Wide big end bearing	mm (in)	21.973...22.025 (0.8651...0.8671)		
Big end bearing endplay	mm (in)	0.130...0.312 (0.0051...0.0123)		
Wear limit	mm (in)	0.400 (0.0157)		
Piston pin bore dia.	mm (in)	20.000...20.021 (0.7874...0.7882)		
Piston pin bore dia. with bushing	mm (in)	18.000...18.021 (0.7087...0.7095)		
Distance between centers				
	up to 1992 model year	mm (in)	125.0 (4.9213) ± 0.1 (0.0039)	
	from 1993 model year on	mm (in)	131.0 (5.1575) ± 0.1 (0.0039)	
Permissible weight difference	g	± 4		
Cylinders				
Bore				
	A	mm (in)	70.500 (2.7756) ± 0.005 (0.0002)	
	B	mm (in)	70.510 (2.7760) ± 0.005 (0.0002)	
Wear limit		mm (in)	+ 0.05 (0.002)	
Pistons				
Weight group identification			stamped + or -	
Piston dia. Make: KS				
	A	mm (in)	70.473 (2.7745) ± 0.007 (0.0003)	
	B	mm (in)	70.483 (2.7749) ± 0.007 (0.0003)	
Direction of installation			Arrow on piston crown points forward	
Installed clearance	mm (in)	0.015...0.039 (0.0006...0.0015)		
Wear limit	mm (in)	0.130 (0.0051)		

Technical data			K 1100 LT	K 1100 RS
Piston rings				
1st groove	Rectangular-section			
	Height	mm (in)	1.175...1.190 (0.0462...0.0469)	
	Wear limit	mm (in)	1.100 (0.0433)	
Ring gap		mm (in)	0.20...0.40 (0.0079...0.0157)	
	Wear limit	mm (in)	1.50 (0.059)	
Side clearance		mm (in)	0.040...0.075 (0.0016...0.0030)	
	Wear limit	mm (in)	0.30 (0.0118)	
2nd groove	Micro-chamfer			
	Height	mm (in)	1.178...1.190 (0.0464...0.0469)	
	Wear limit	mm (in)	1.100 (0.0433)	
Gap		mm (in)	0.10...0.30 (0.0039...0.0118)	
	Wear limit	mm (in)	0.300 (0.0118)	
3rd groove	Equal-chamfer ring with tubular spring			
	Height	mm (in)	2.475...2.490 (0.0974...0.0980)	
Gap		mm (in)	0.20...0.45 (0.0079...0.0177)	
	Wear limit	mm (in)	1.50 (0.0591)	
Side clearance		mm (in)	0.020...0.055 (0.0008...0.0022)	
	Wear limit	mm (in)	0.30 (0.0118)	
Installed direction of piston rings			Top marking facing up (grooves 2 and 3)	
Piston pin				
Piston pin dia.		mm (in)	18 (0.7087) ^{-0.004 (0.0002)}	
	Wear limit	mm (in)	17.96 (0.7071)	
Bore dia. in piston		mm (in)	18.002...18.006 (0.7087...0.7089)	
Play in piston		mm (in)	0.002...0.010 (0.00008...0.00039)	
Play in conrod		mm (in)	0.006...0.021 (0.00024...0.00083)	
	Wear limit	mm (in)	0.060 (0.00236)	

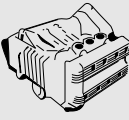

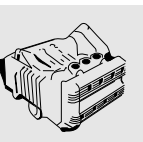

Removing engine

- Remove fuel tank.
- Remove knee pads.
- Remove fuel tank.
- Remove lower section of fairing at left and right.
- Remove radiator surround.
- Drain coolant.
- Remove radiator.

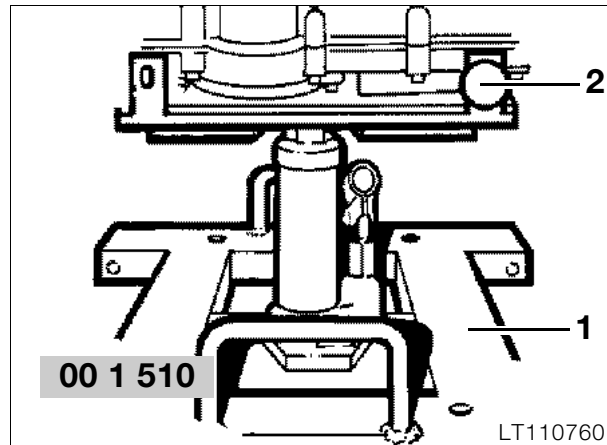

- Attach hoist, **BMW No. 00 1 510**, to oil sump.
- Remove rear shield plate with coolant level equalising tank.
- Remove Motronic control unit.

Caution:

Detach negative battery terminal first, then positive terminal. Connect the positive battery terminal first, then the negative terminal.

- Remove the battery.

Caution:

Do not allow brake fluid to come into contact with painted parts of the motorcycle, because brake fluid destroys paint.

- Drain the brake fluid.

Caution:

Avoid damage to the brake lines.

- **(ABS I)** Detach both pressure modulators and secure them to the frame.
- **(ABS II)** Remove the ABS unit.
- Detach the brake hose fastening at the battery carrier.
- Remove the left footrest plate.
- Remove the right footrest plate together with the brake line and master brake cylinder.

- Detach the engine wiring harness.
- Separate the plug connections for the speed and ABS signals.
- Detach the throttle cable.
- Detach the choke cable.
- Disconnect clutch cable.
- Remove the exhaust system.
- Remove suspension strut.
- Detach engine mounting at frame.
- Secure front wheel to hoist.

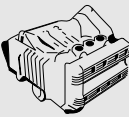
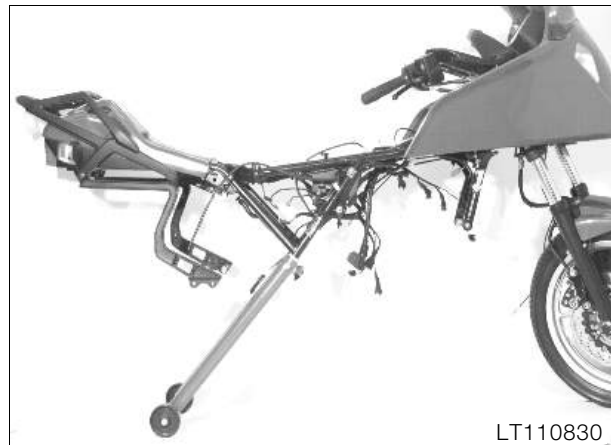

- Raise the frame with telescopic fork and frame support, **BMW No. 46 5 620**, over the engine block, and set it down.
- Remove the battery holder.
- Remove the starter motor.
- Remove the coils.
- Remove the main (centre) stand.
- Take out the two lower gearbox bolts.
- Screw the main (centre) stand on hand-tight.
- Remove the alternator cover.

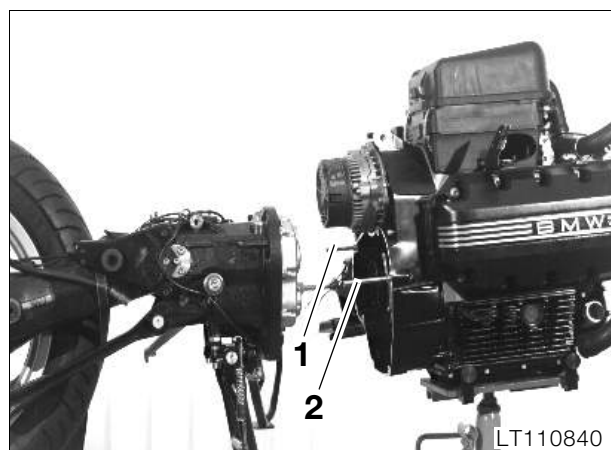

- Screw guide pins (1) und (2), **BMW No. 23 1 820**, into the holes with the reamed sleeve; the longer pin (2) must be at the right.
- Pull the gearbox off slowly.

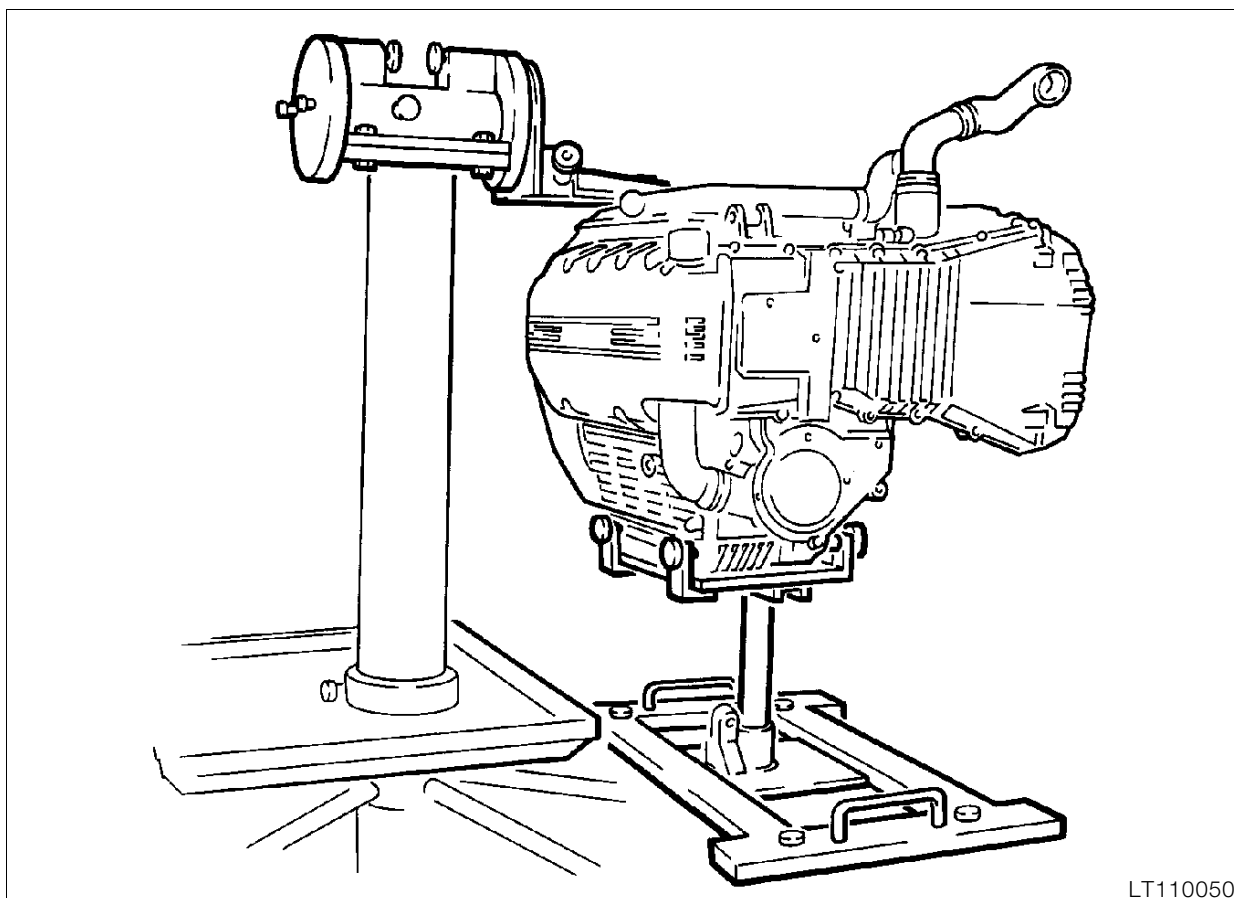

LT110050

Dismantling engine

- Remove air cleaner box.
- Remove fuel injection rail.
- Remove throttle rail.

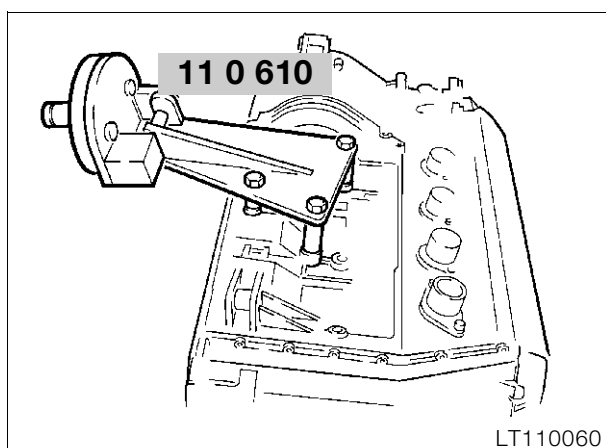

LT110060

- Attach engine mount, **BMW No. 11 0 610**, to the engine block.
- Lower the hoist and support the engine on assembly stand, **BMW No. 00 1 490**.
- Remove the hoist.
- Drain the oil.

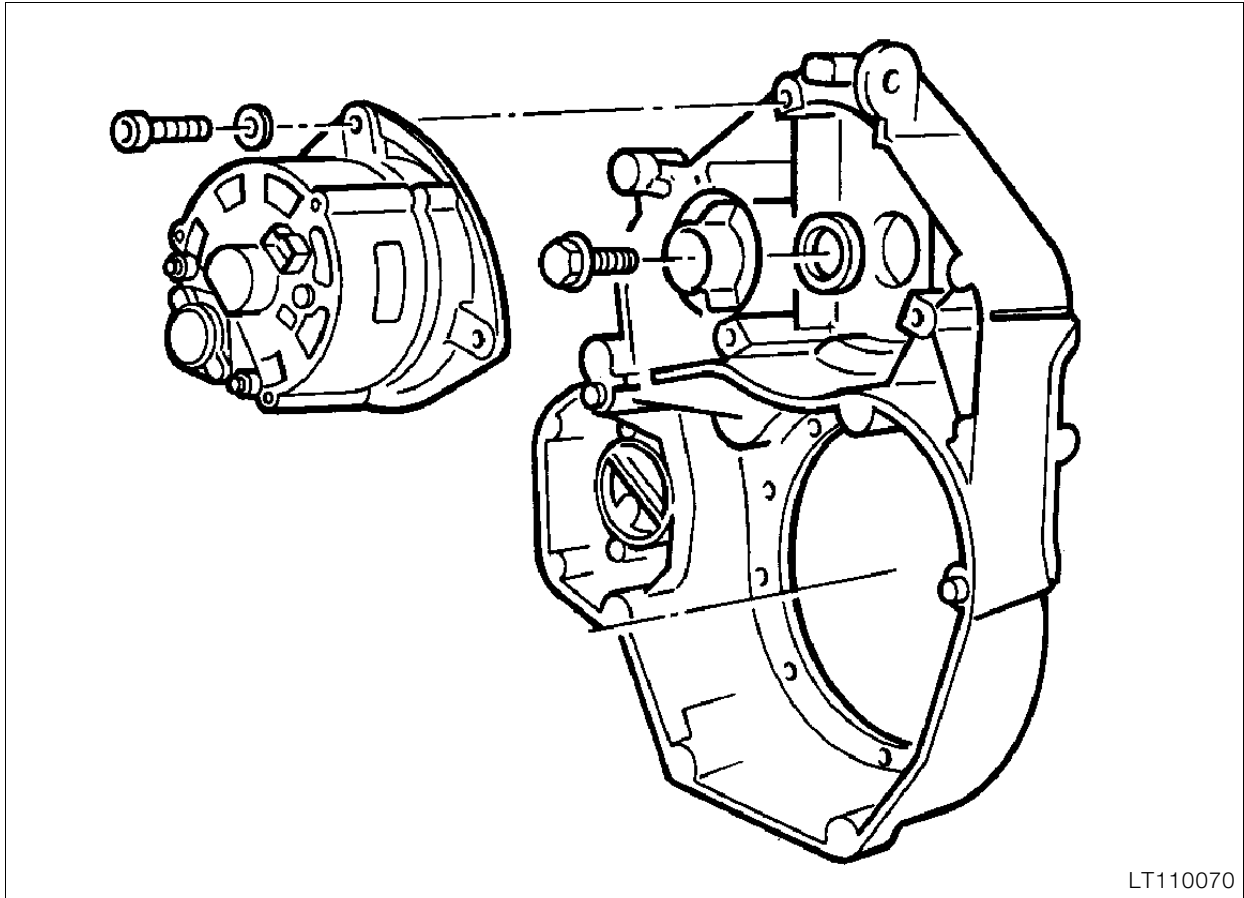

LT110070

Removing intermediate flange

- Remove alternator.
- Remove coils with holder.

Removing driver

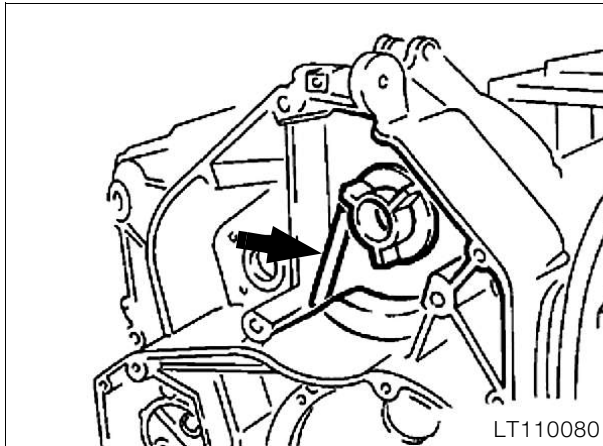

LT110080

- To remove the screw, support the driver (arrow).
- Pull the driver off by hand.

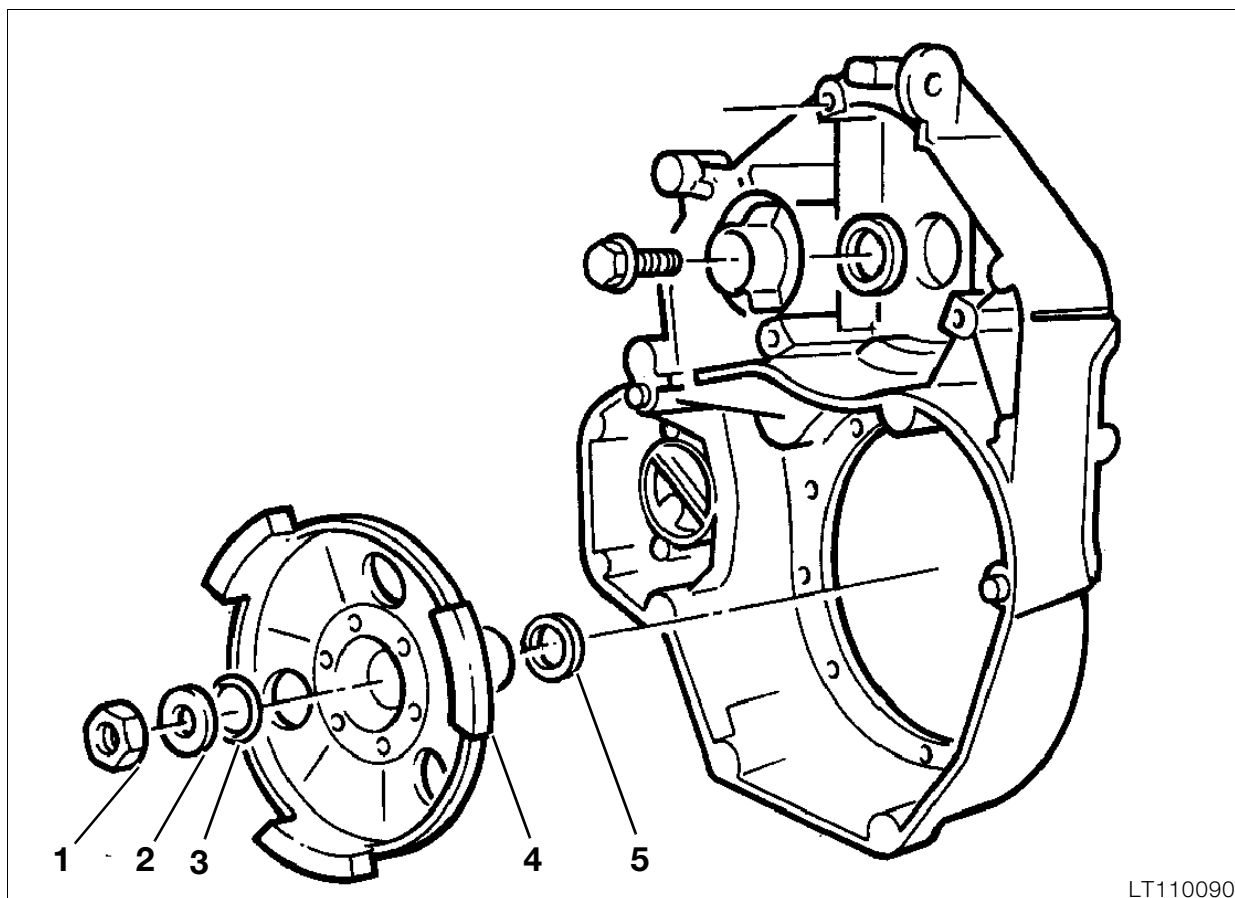
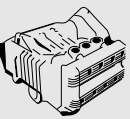

LT110090

Removing clutch housing

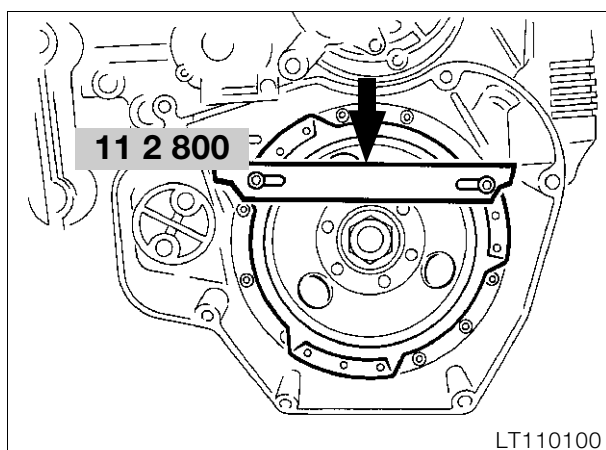

LT110100

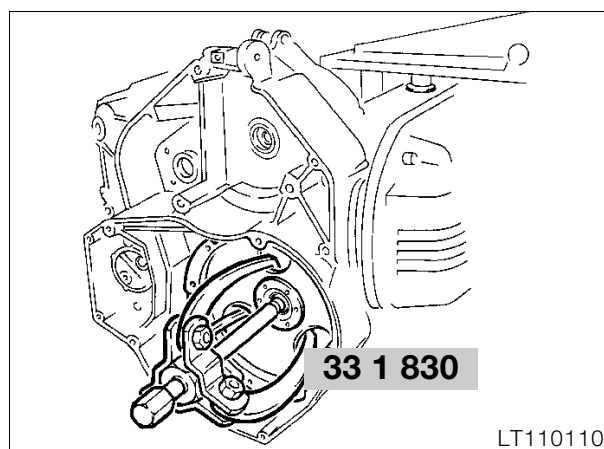

LT110110

- Install the retaining device (arrow), **BMW No. 11 2 800**, in the position illustrated.
- Unscrew hex nut (1) and take off thrust ring (2).
- Push O-ring (3) forwards with the clutch housing and remove with a hook.
- Pull out clutch housing (4), noting the presence of thrust washer (5).
- If necessary, pull the clutch housing off with a three-arm puller, **BMW No. 33 1 830**.
- Remove the intermediate flange.

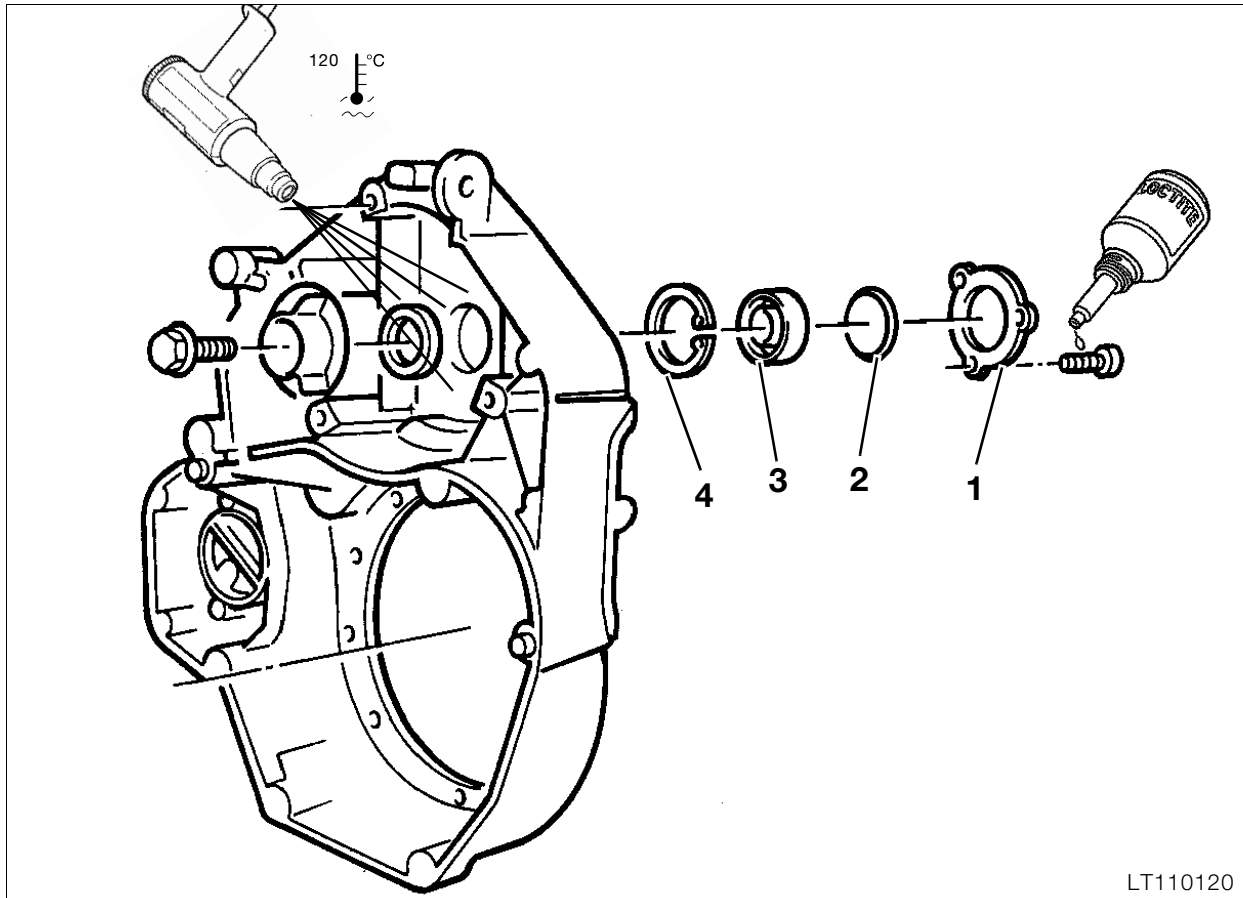

LT110120

Stripping down and re-assembling intermediate flange

Removing the driver bearing

- Bearing plate (1)
- Cup spring (2)
- Pull out ball bearing (3) with counter-support, **BMW No. 00 8 572**, and internal puller 21/2, **BMW No. 00 8 571**.
- Seeger circlip (4)

Installing driver bearing

- Heat the intermediate flange at the bearing seat to 120 °C.
- Press the ball bearing in as far as the Seeger circlip.

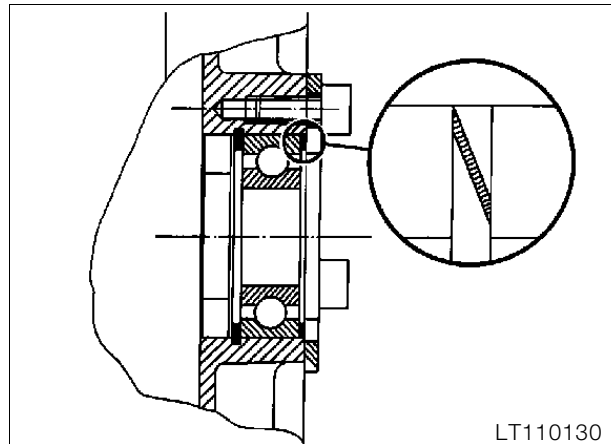

LT110130

- Insert the cup spring with the larger diameter facing the bearing.
- Install the bearing plate with the large cutout facing upwards.
- The retaining screws must be clean and free from grease; insert them with **Loctite 243**.



Tightening torque:

Bearing plate..... 9 Nm

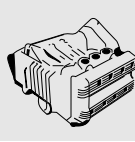

Removing and installing shaft sealing ring for driver

- If the intermediate flange has been removed, lever out the sealing ring.

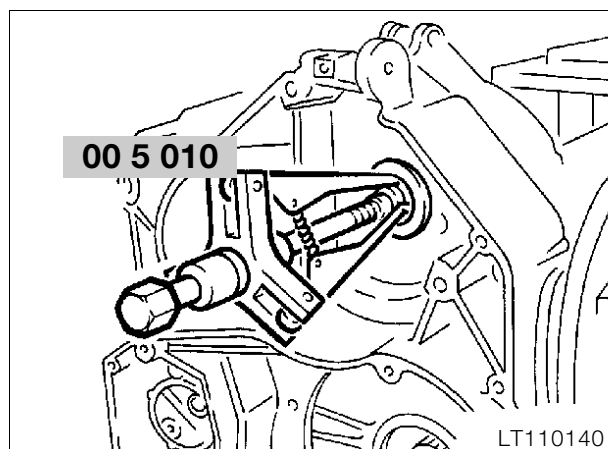

- If the intermediate flange is installed, pull out the sealing ring with an internal puller, **BMW No. 00 5 010**, and pressure head.
- Pre-shape the sealing ring, which must be dry, with the thumb and drive it in with drift, **BMW No. 11 1 620**, and handle, **BMW No. 00 5 500**.

Removing countershaft and layshaft with freewheel

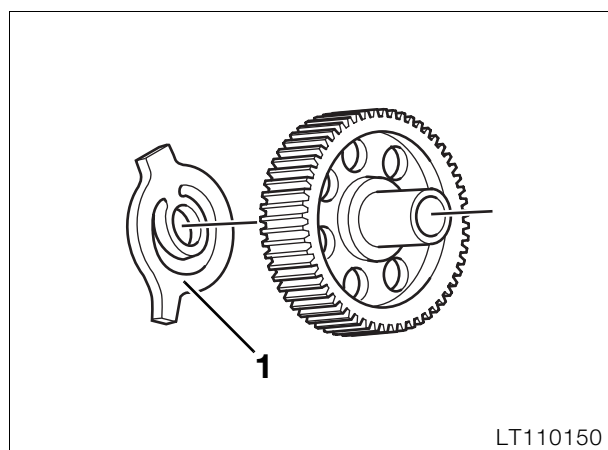

- Pull countershaft and layshaft out of the engine block together.
- Note flat spring (1).

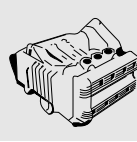
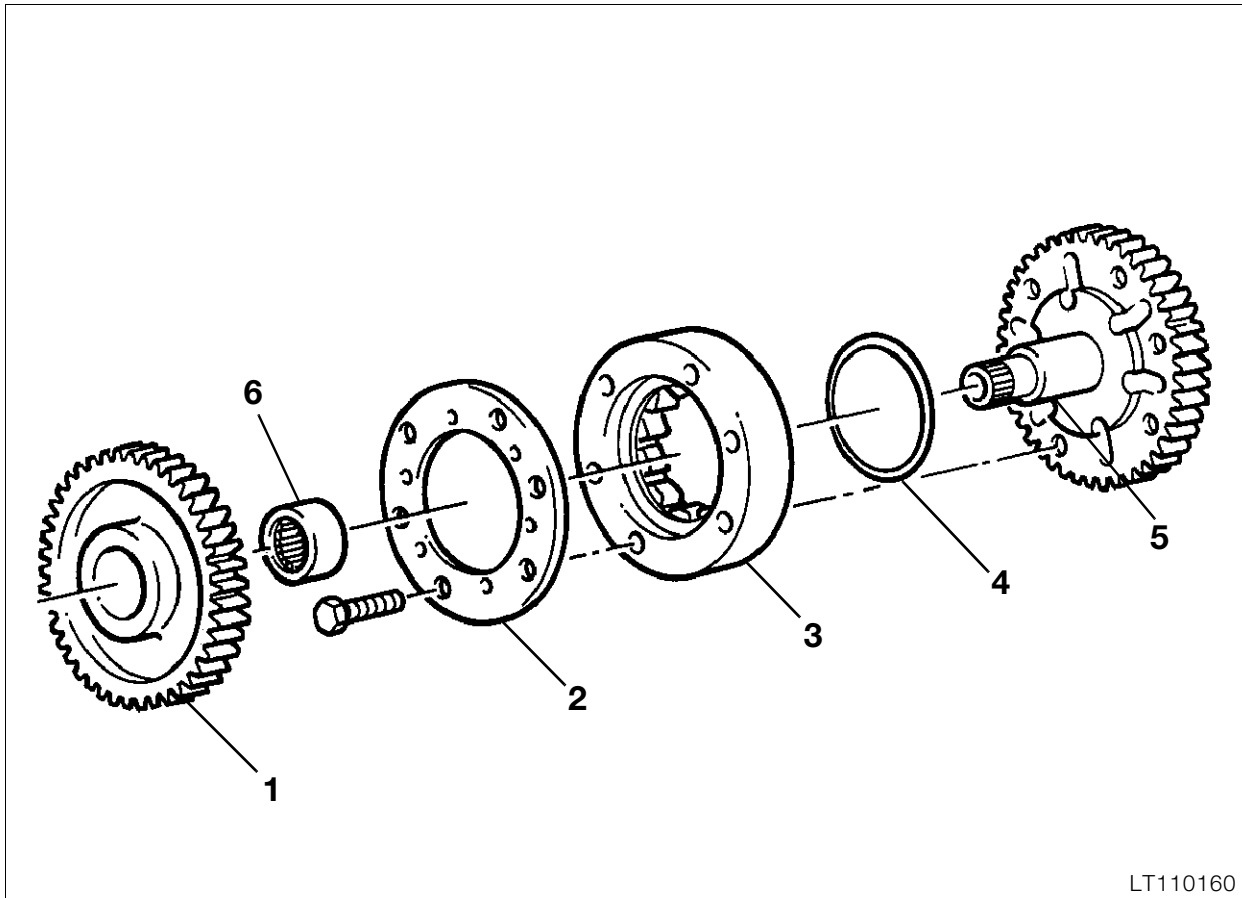

LT110160

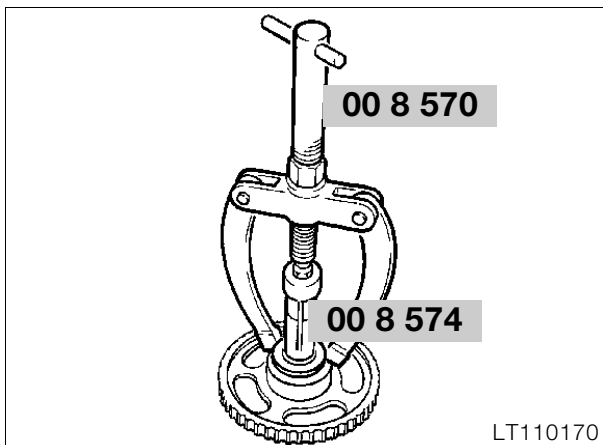

LT110170

Dismantling and assembling freewheel

Stripping down freewheel

- Pull freewheel gear (1) off layshaft (5).
- Clamp the layshaft into a vice with soft jaws (smooth side down).
- Remove cover plate (2).
- Pull off freewheel cage (3).
- Take out cup spring (4).
- Pull needle roller bearing (6) out of the freewheel gear with counter-holder, **BMW No. 00 8 570**, and internal puller 21/3, **BMW No. 00 8 574**.

Assembling freewheel

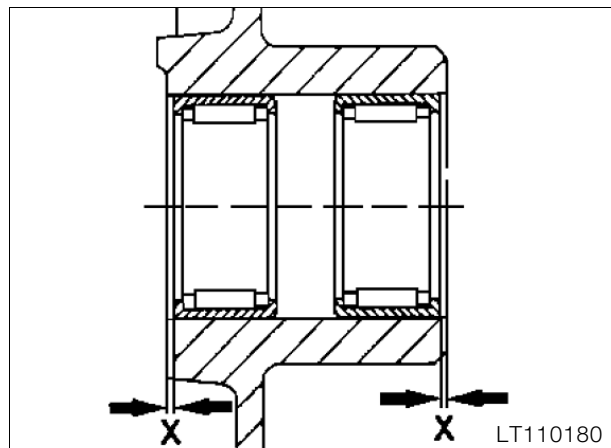

LT110180

- Press the needle roller bearing into the freewheel gear so that distance (x) is the same at both sides.

Distance "X" 0.4 ± 0.2 mm (0.016 ± 0.008 in)

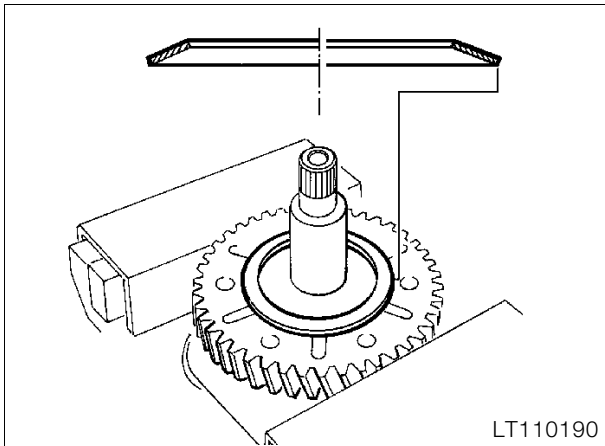
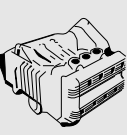

Removing and installing layshaft needle roller bearing

Removing bearing

- Heat the bearing seat to 100 °C.
- Pull out the bearing with counter-support, **BMW No. 00 8 570**, and internal puller 21/3, **BMW No. 00 8 574**.
- If the bearing is defective and cannot be pulled out, carefully cut through the needle roller sleeve with a grinder.

Installing bearing

- Heat the bearing seat to 120 °C.
- Centre the bearing and drive it in with a 21 mm (0.82 in) drift with a pin of smaller diameter (15.95 mm/0.628 in).

- Place the cup spring in position.
- Insert the freewheel (oiled with engine oil) into the outer race.
- Install the outer race (with clamp block facing cover plate); the cup spring must snap into the outer race.
- Place the cover plate in position.



Tightening torque:

Retaining screws..... 10 Nm

- Push the freewheel gear on to the layshaft while turning it clockwise.
- Push the thrust washer and O-ring on to the layshaft.

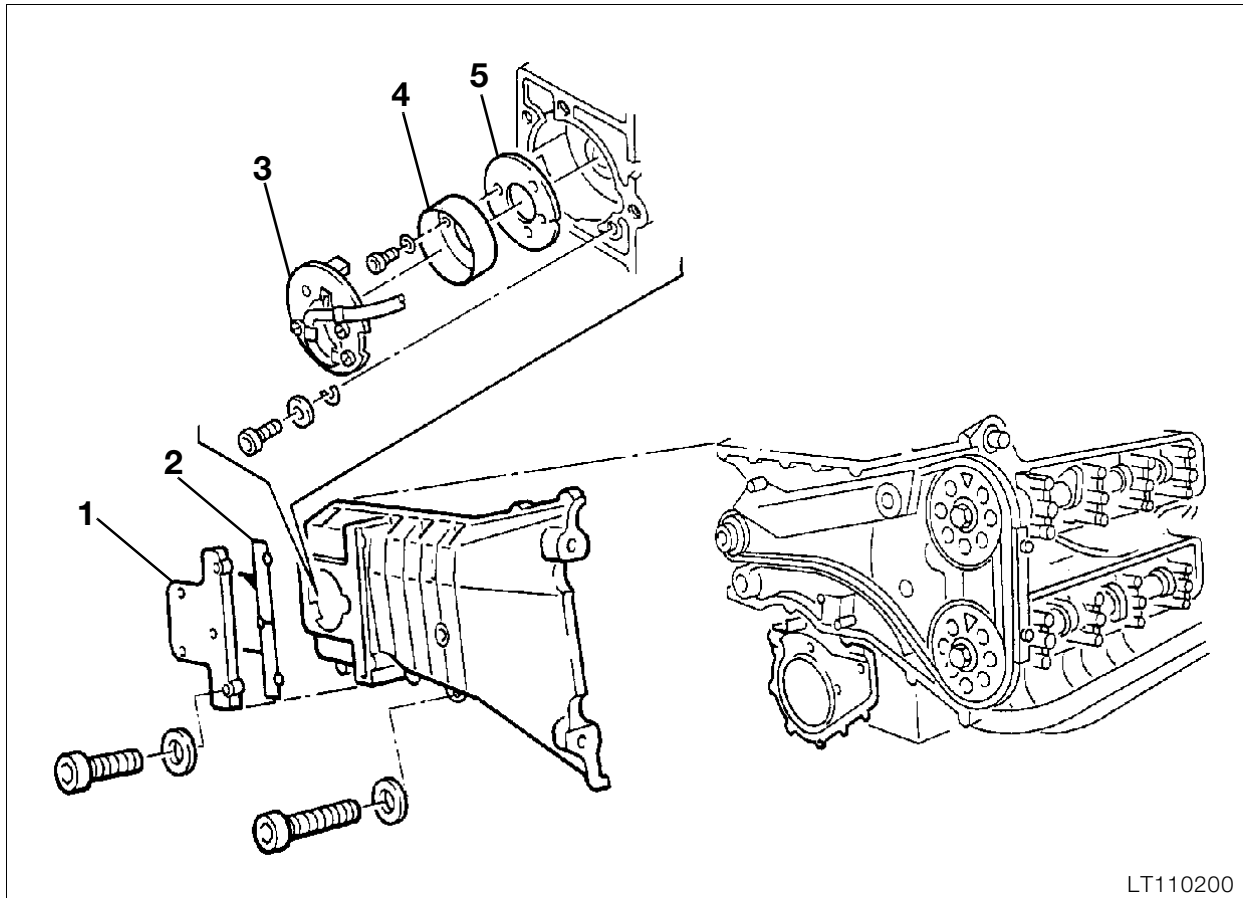

LT110200

Removing timing chain cover

Removing the Hall-effect signal transmitter

- Remove cover (1).
- Take off gasket (2).
- Remove Hall-effect signal transmitter (3), noting the semi-circular shim washers.



Note:

Mark the correct installed position of the adjusting washer on the engine block, or remove it in the TDC position.

- Remove gate rotor (4) and take off adjusting washer (5).

Remove the crankshaft cover

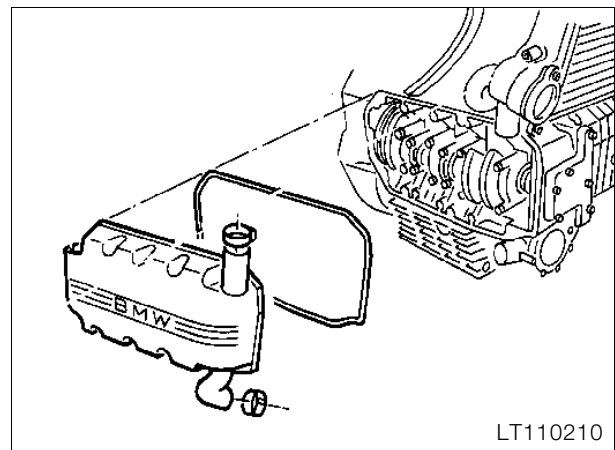

LT110210

- Detach the coolant hose at the water pump and radiator.
- Remove the cover.

Removing cylinder head cover

- Remove the ignition leads.
- Remove the cylinder head cover.

Removing and installing sealing ring in timing case cover

- Drive the sealing ring out with a suitable drift.
- Drive the sealing ring in from the inside using handle, **BMW No. 00 0 500**, and drift, **BMW No. 11 1 610**.

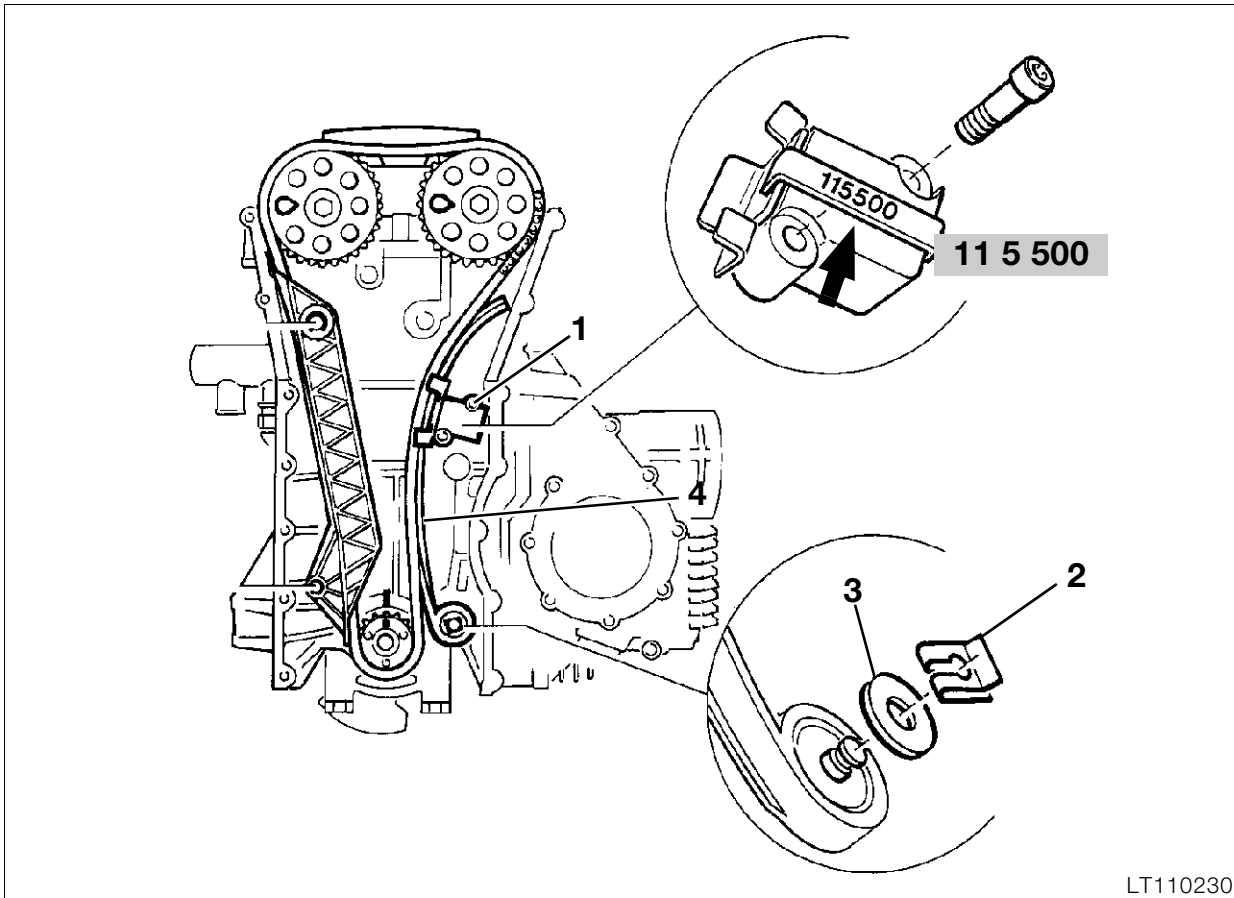
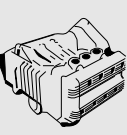

LT110230

Removing the timing chain

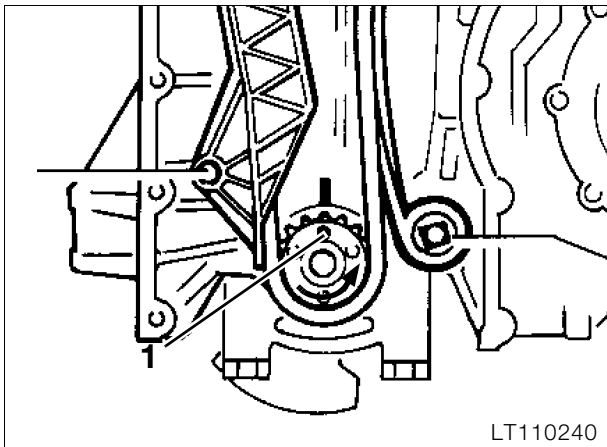

LT110240

- Set cylinder 1 (timing end) to TDC, noting direction of rotation (arrow). Pin (1) on the crankshaft must be aligned with the marking on the housing.

Removing chain tensioner

- Secure chain tensioner (1) with clamp, **BMW No. 11 5 500**, (arrow) and remove it.

Removing chain tensioner rail

- Remove clip (2) and washer (3).
- Pull out tensioner rail (4).

Renewing chain tensioner rail facing

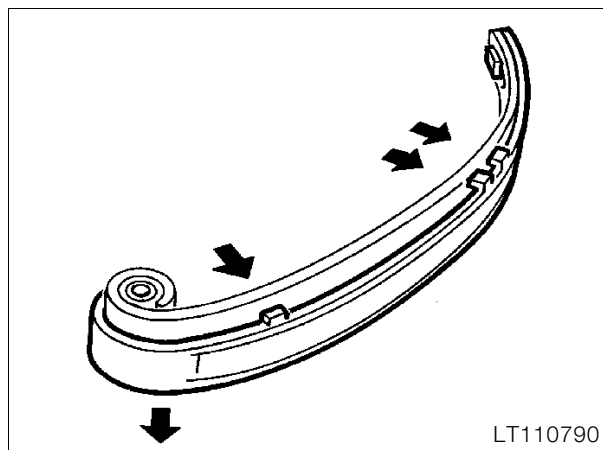

LT110790

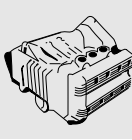
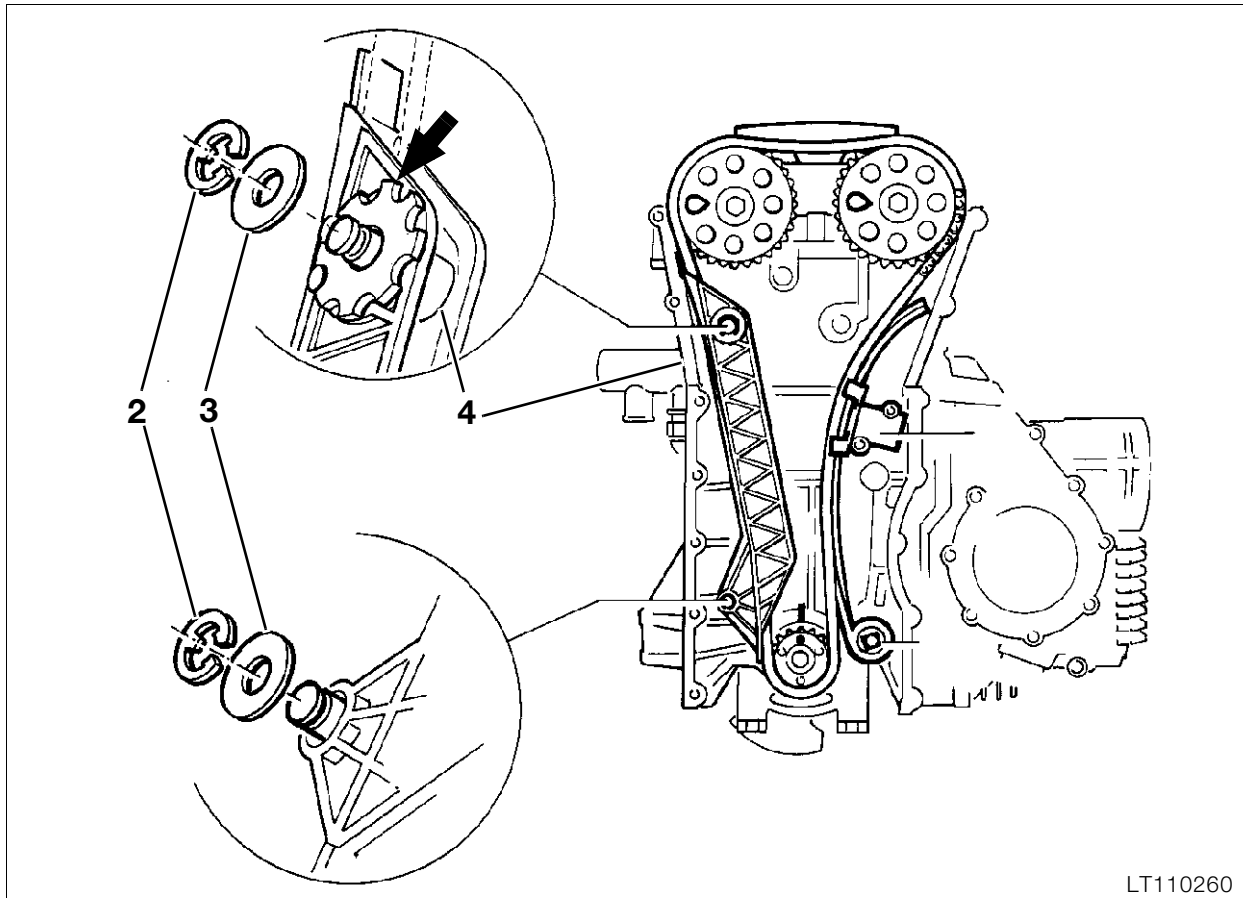

Removing camshaft chain sprockets

- When taking out the retaining screws, hold the hexagon on the camshaft to prevent it from turning.

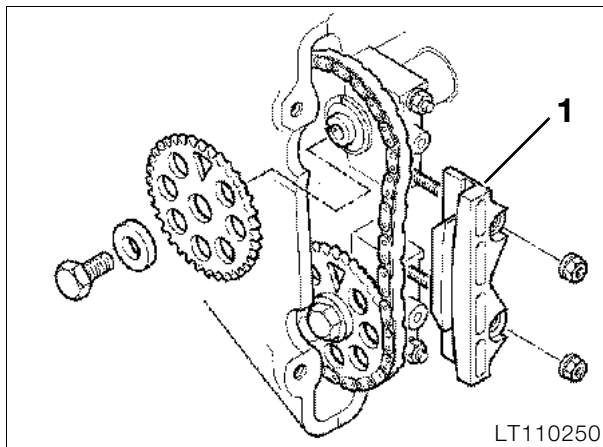

- Remove chain guide (1).

Removing chain guide

- Remove keepers (2) and washers (3) at the pivot pins.
- Raise chain guide (4) slightly at the cylinder head and press it down again.
- The toothed washer with eccentric (arrow) must project slightly.
- Pull out the toothed washer.
- Take off the chain guide with the timing chain.

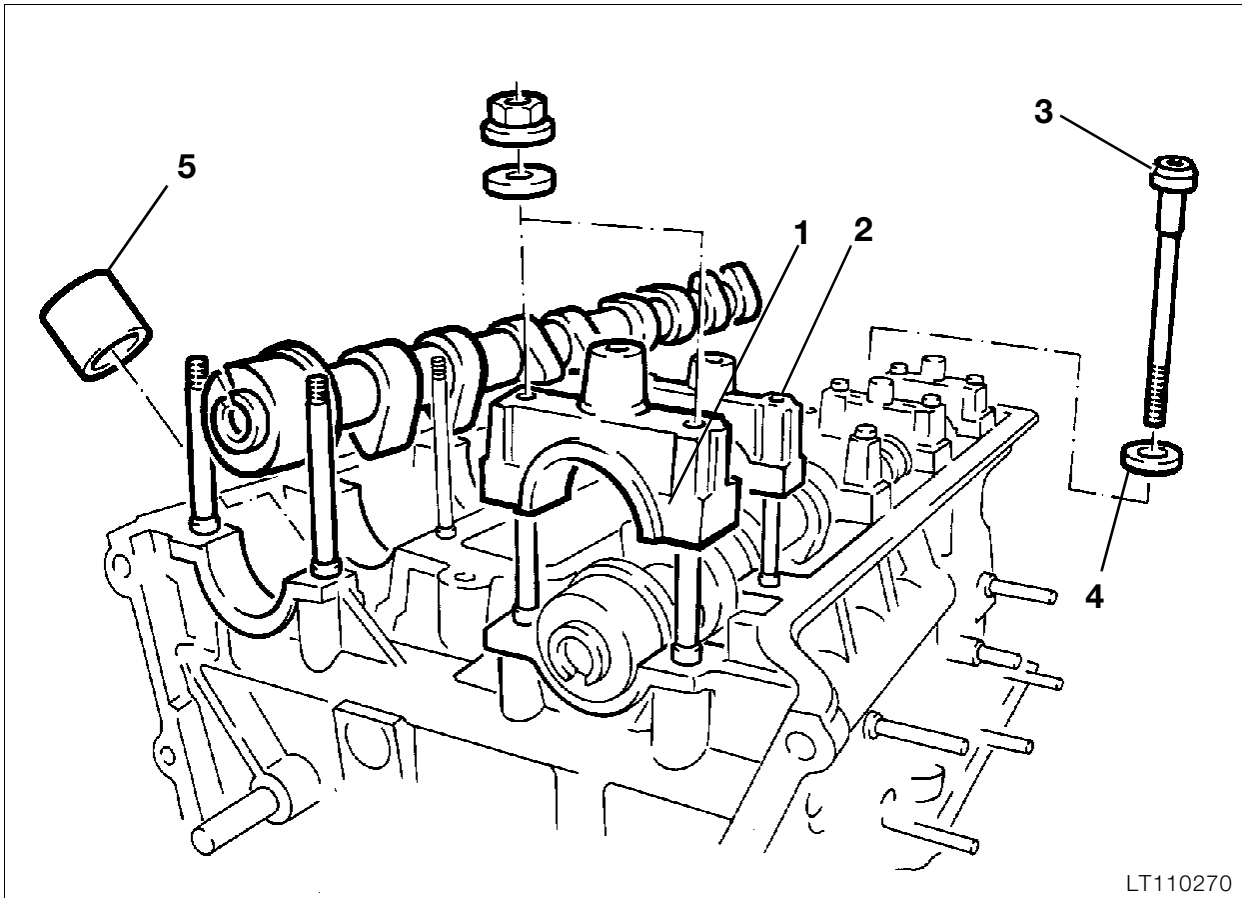

LT110270

Removing, stripping down and assembling cylinder head

Removing camshafts

- Remove the bearing caps (1) for the thrust bearings first, to prevent tilting.
- Release tension uniformly at radial bearing caps (2) and remove them.
- Take out the camshafts.

Removing cylinder head

- Unscrew the cylinder head bolts (3) with Torx insert, **BMW No. 00 2 610**.
- Strike the cylinder head lightly with a plastic-faced hammer to dislodge it.

Removing bucket-type tappets

- Using special suction tool, **BMW No. 11 3 251**, pull bucket tappets (5) out of the cylinder head.
- Make a note of which tappet belongs to which valve.

Removing valves

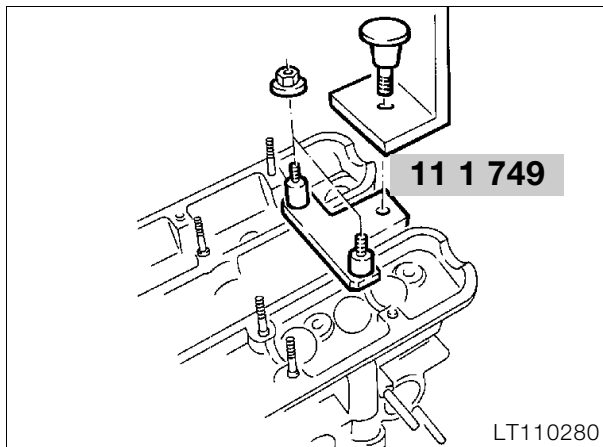

- Screw support plate, **BMW No. 11 1 749**, for the valve spring clamping tool on to the rear of the cylinder head.

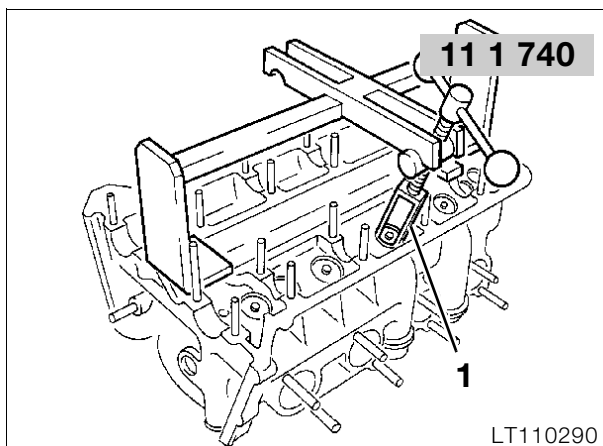

- Attach valve spring clamping tool, **BMW No. 11 1 740**.
- Use pressure cage (1), **BMW No. 11 1 748**.
- Place the cylinder head flat on a wooden board and clamp the valve spring.

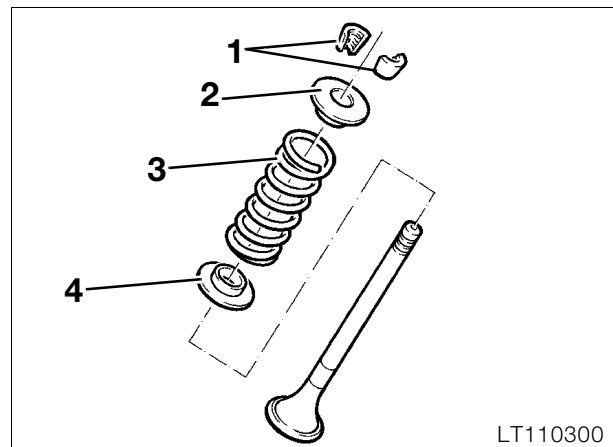

- Pull valve collets (1) out with a magnetic screwdriver.
- Release valve spring (3) and remove the various components.
- Upper spring plate (2), lower spring plate (4).
- Pull out the valve stem seal with pliers, **BMW No. 11 1 250**.

Remachining valve seat

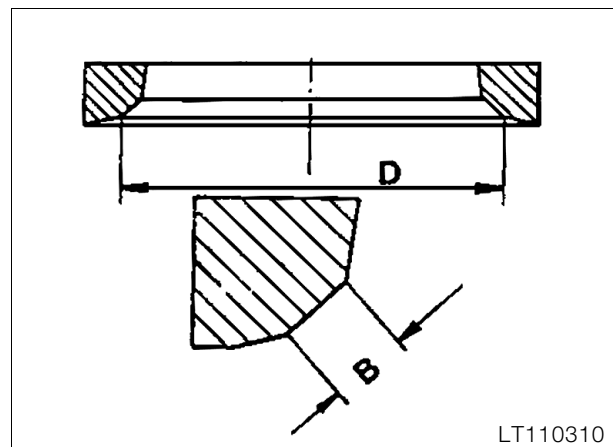

D = valve diameter
B = valve seat width

- When remachining, the correct width of the valve seat must always be maintained.



Note:
Machine the valve seat with turning tool, **BMW No. 11 0 500**.

- If the valve seat has been remachined, a new valve must be installed.

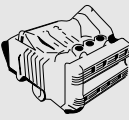

Installing valve and valve stem seal



Note:

If a valve was removed, the valve stem seal must be renewed.

- Oil the stem when installing the valve.
- Insert the lower spring plate.

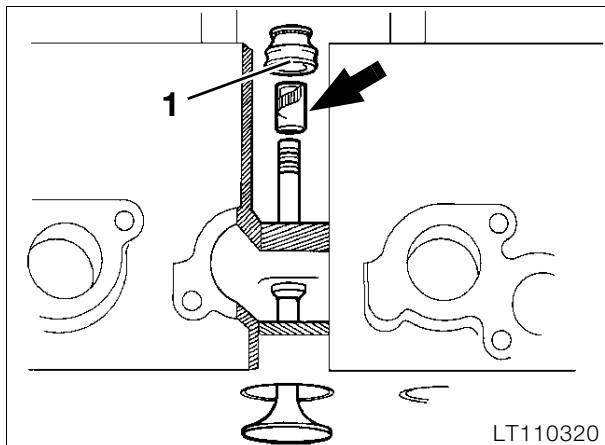

- Push assembly sleeve (arrow), **BMW No. 11 1 960**, on to the valve stem.
- Drive in sealing ring (1) with drift, **BMW No. 11 5 601**, until the drift reaches the cylinder head.



Caution:

Remember to remove the assembly sleeve from the valve stem.

- Insert the valve spring.
- Install the upper spring plate.
- Clamp the valve spring, lightly oil the valve collets and insert them, then release the spring.
- Clean and oil the bucket-type tappet before inserting.

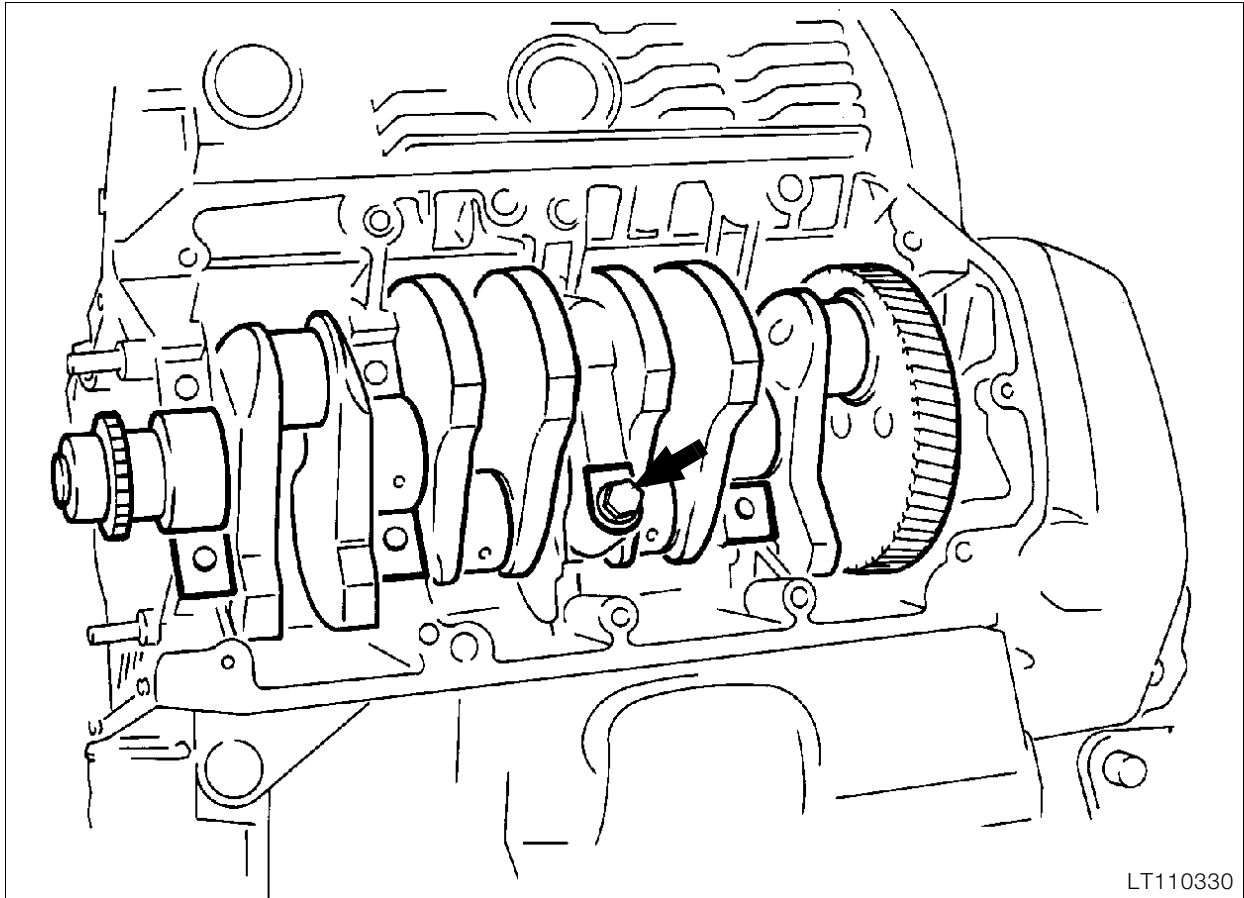

LT110330

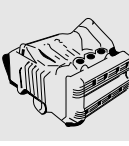

Removing crankshaft

Removing big end bearings

- Move the piston in cylinders 1 and 4 to the bottom dead centre (BDC) position.

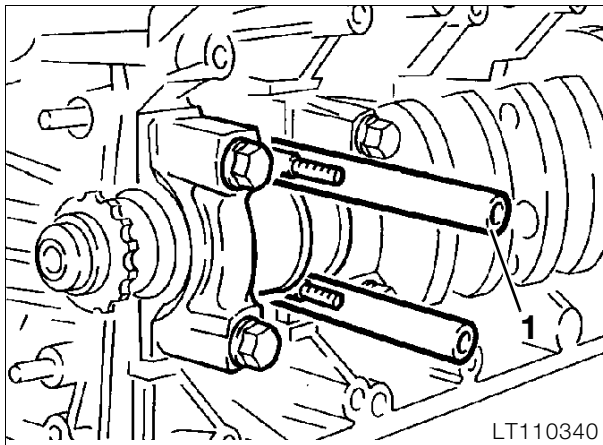

LT110340

- Remove the big end bearing caps.



Note:

Push protective tube (1) (app. 50 mm (2 in) long) on to big end bolts.

- Repeat the work sequence at cylinders 2 and 3.

Removing main bearings

- Take out all main bearing bolts except one (arrow).
- Take off the bearing caps.
- Take out the last bolt.
- Take off the bearing cap, pressing the crankshaft in towards the housing while doing so.



Note:

Bearing caps 1-3 are marked for identification. Bearing 4 (thrust bearing) and bearing 5 are not marked. Cylinder 1 = timing end of engine.

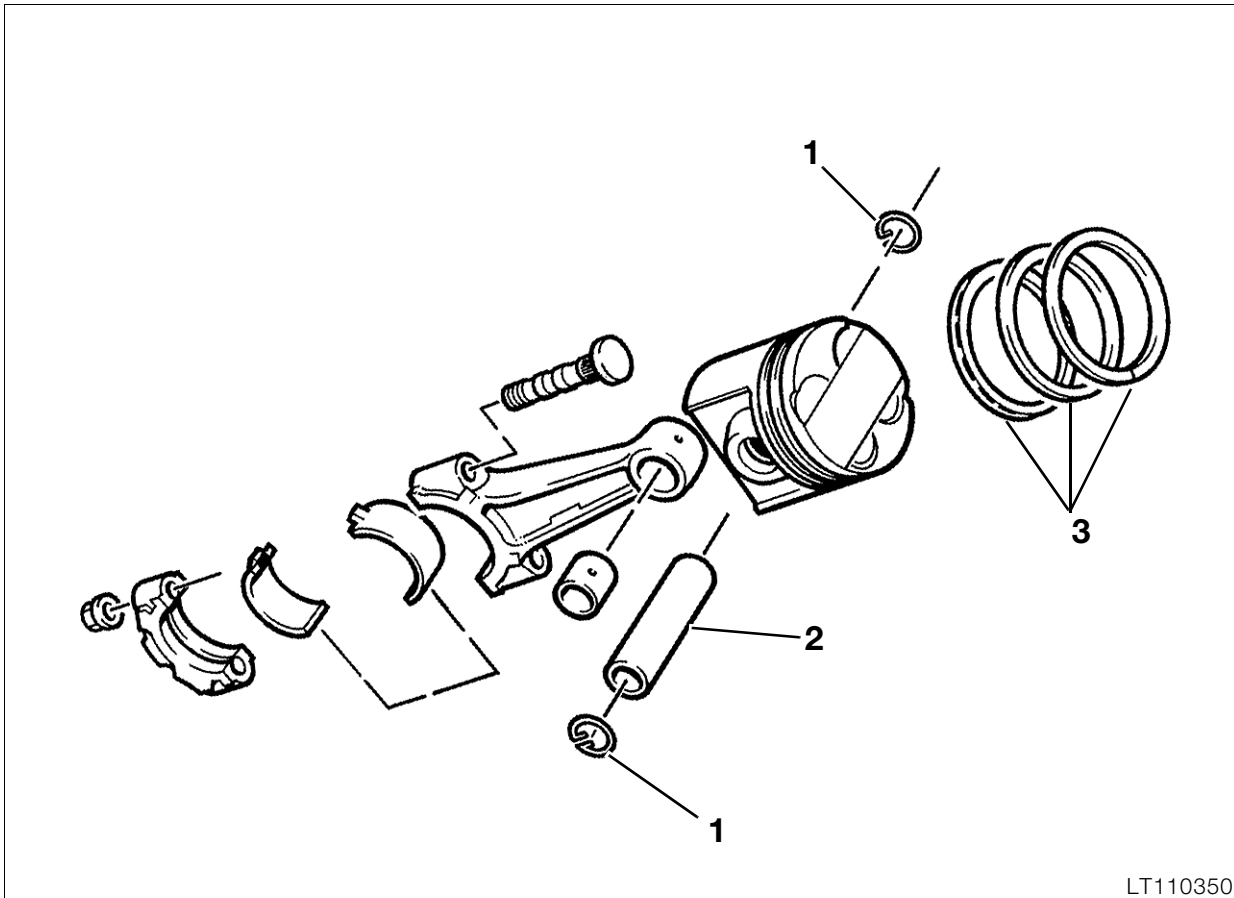
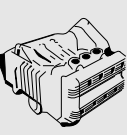

LT110350

Removing pistons with conrods, stripping down and re-assembling

Removing piston with conrod

- Press the piston with conrod out from the crankshaft side.

Dismantling piston

- Remove the circlip (1) at one side.
- Press out piston pin (2) with drift, **BMW No. 11 2 930**.
- Carefully remove piston rings (3).
- Clean the piston.

Checking piston dimensions

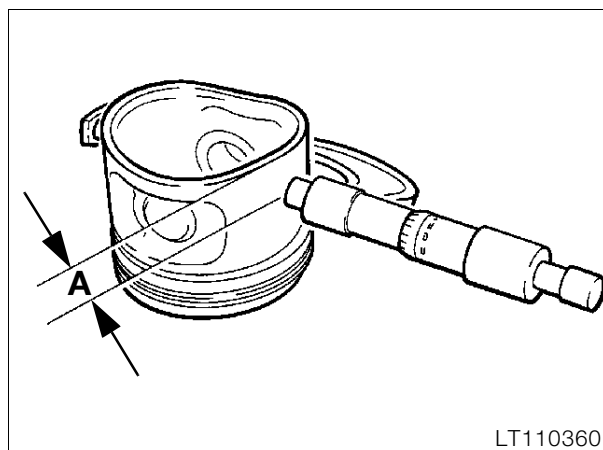

LT110360

- Measure piston diameter with a micrometer at distance "A".

Make:	Dimension "A"
KS.....	12.0 mm (0.472 in)
Mahle.....	7.6 mm (0.299 in)

- Measure piston ring side-flank clearance with feeler gauges.
- Measure the piston ring end gap in the cylinder.

For side clearance and gap, see Technical data page 11.9

Assembling pistons

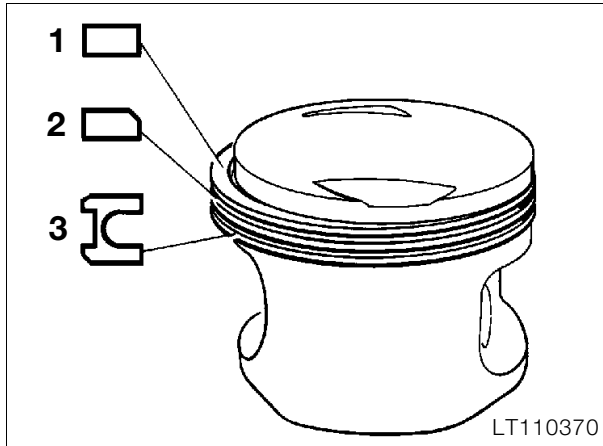

- Install piston rings, using piston-ring pliers.
 - 1st groove: rectangular-section ring
 - 2nd groove: micro-chamfer ring (note pin for ring gap and TOP marking).
 - 3rd groove: equal-chamfer ring with tubular spring, (note TOP marking).



Note:

The tubular spring gap must be offset by 180° from the equal-chamfer ring gap.

Removing and installing small-end bushing

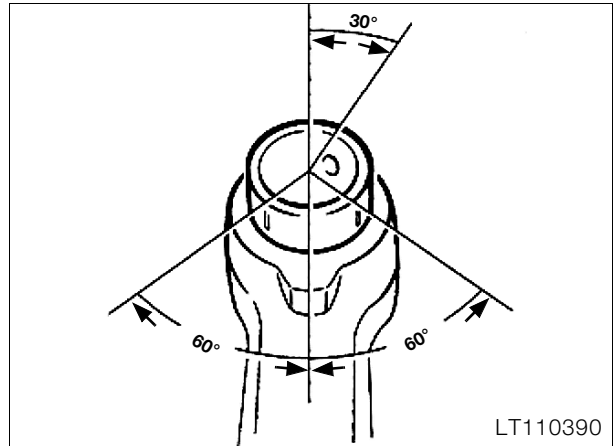

- Press out the small-end bushing.
- The gap in the new bushing, when pressed in, must be at an angle of 60° either to the left or the right of the centre axis.
- Ream out the small-end bushing.
- Drill the oil hole and deburr it.

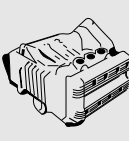

Caution:

It should be possible to push the piston pin through the small-end bushing with only light pressure.

Checking cylinder dimensions

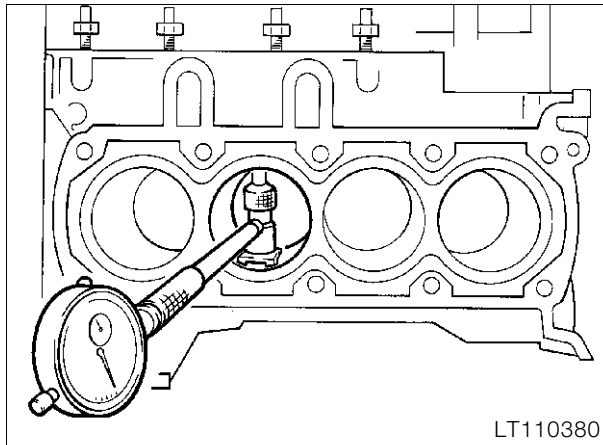

- Set the internal micrometer to the nominal cylinder bore diameter.
- Measure the cylinder bore at three heights and in a crosswise pattern: in the direction of forward travel and at a right angle to it.

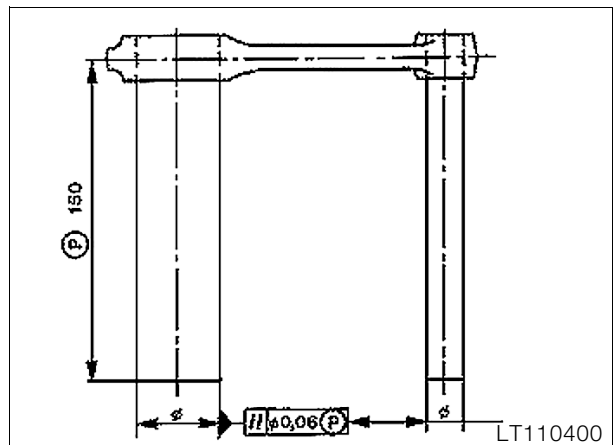

- Check that conrod bores are parallel.
- The difference over the measured length "P" must not exceed 0.06 mm (0.0024 in).

Measured length "P"..... 150 mm (5.906 in)

Assembling pistons and conrods



Note:

[LT] Modified conrod length and pistons from 1993 model year on

- Comply with conrod weight tolerances.

Weight tolerance± 4 g

- Assemble piston and conrod.

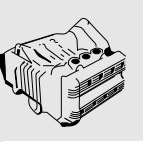

Note:

The oil bore in the conrod eye is on top in the installed position. The arrow marking on the piston crown must point in the forward-travel direction.

- Install only pistons of the same make and the same weight category.



Caution:

Renew the piston pin circlip each time it is removed.

Removing and installing crankshaft pinion and rotor flange

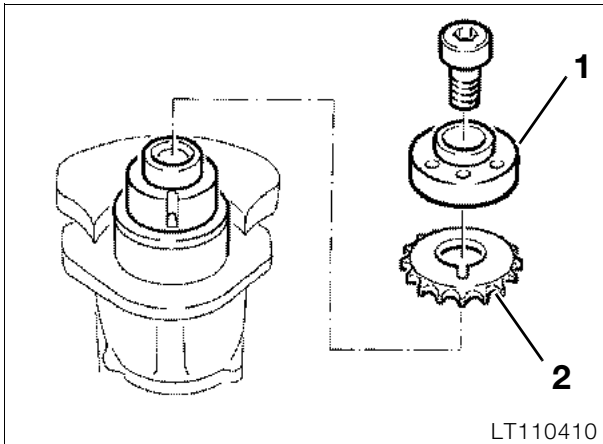

Tightening torque:

Machine screw 50 Nm

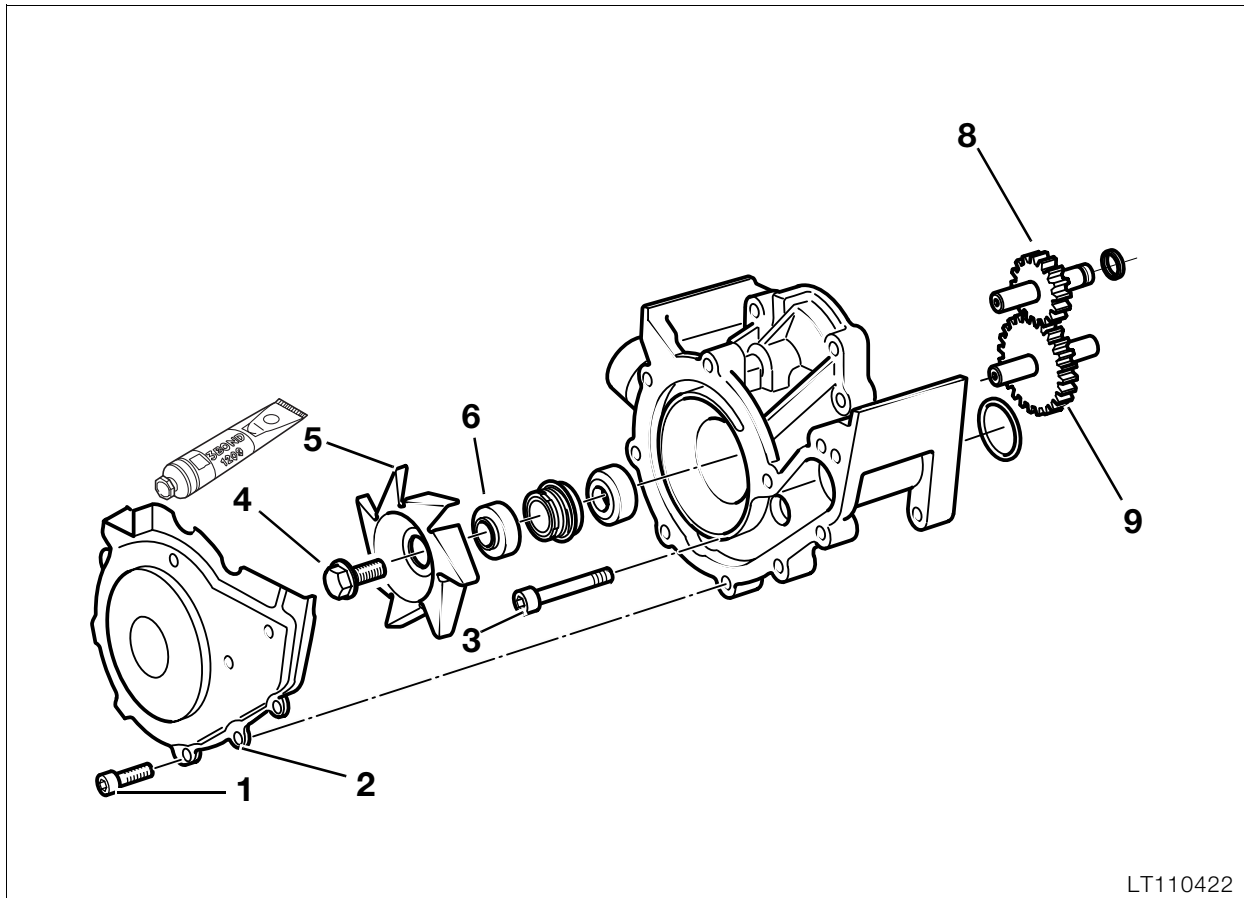

LT110422

Removing, dismantling and assembling combined oil-water pump

Removing pump

- Pull off the wires for the oil pressure and water temperature display at the switch.
- Pull the wires out of the housing.
- Remove housing cover (2) and loosen the gasket with light blows of a plastic-faced hammer.
- Remove the housing and loosen the gasket with light blows of a plastic-faced hammer.
- Pull off the housing.

Dismantling pump

- Clamp the pump housing into a vise at the sealing faces, using soft jaws.
- Remove the impeller (5), holding the pump shaft to prevent it from moving.
- Take off the impeller with spacing bushing (6).
- Pull out pinion (8) and pump shaft (9).
- Examine the pump housing for damage.

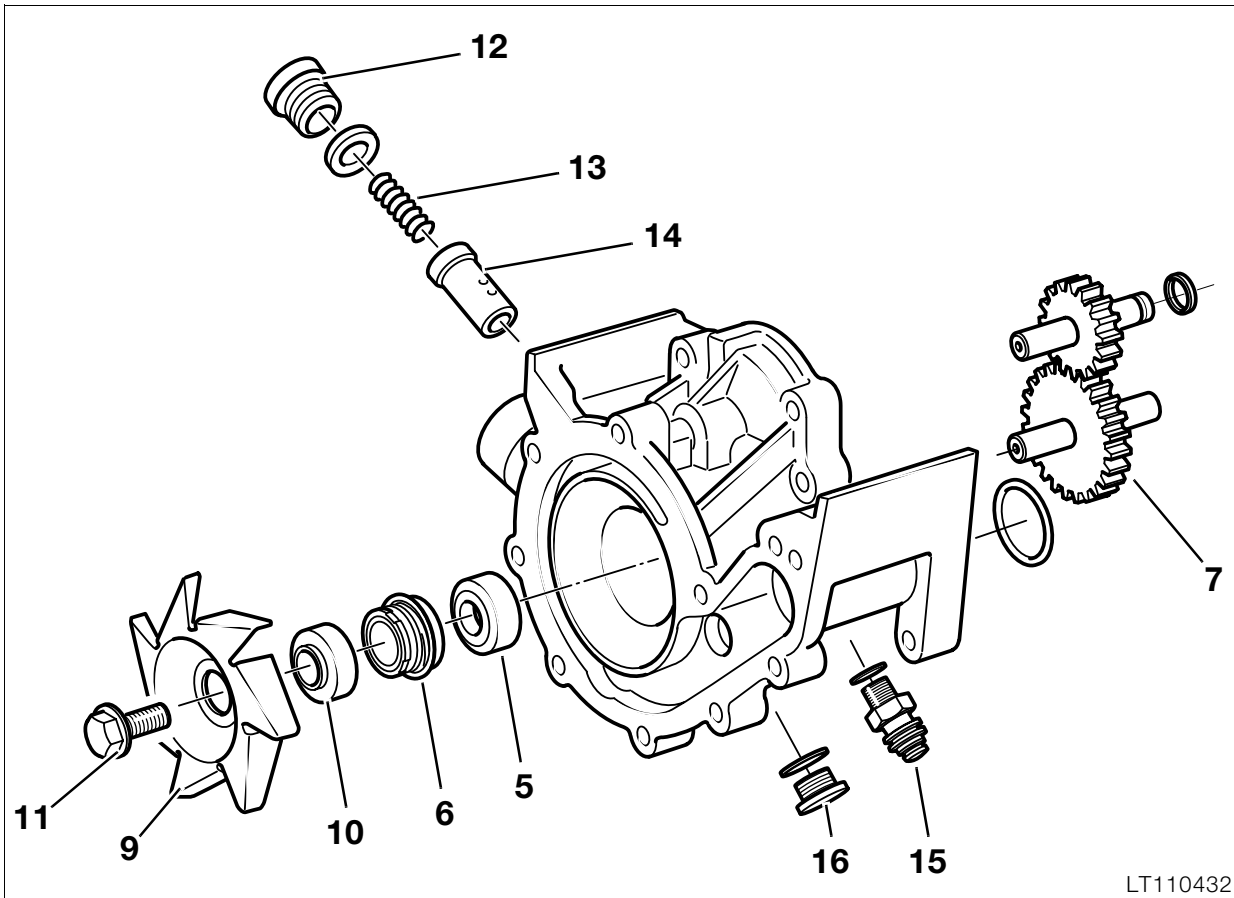
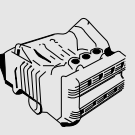

LT110432

Removing slipping seal and shaft sealing ring

- Press out slipping seal (6) with a drift.
- Using a 5 mm (0.2 in) wide screwdriver, carefully press out sealing ring (5).

Removing pressure relief valve

- Loosen threaded union (12) and pull out spring (13).
- Pull valve piston (14) out with a magnet and examine it for damage.

Installing pressure relief valve

- Oil valve piston (14) lightly before installing.
- Insert spring (13) and insert and tighten the screw plug with a new seal.

Install the shaft sealing ring and slipping seal

- Drive in sealing ring (5) from the water side with the open side downwards, using drift, **BMW No. 11 1 640**, and handle, **BMW No. 00 5 500**.
- Press in slipping seal (6) with drift, **BMW No. 23 1 780**, and handle, **BMW No. 00 5 500**.

Installing pump shaft and impeller

- Oil pump shaft (7) lightly and push it into the housing from the oil side.
- Place impeller (9) with spacing bushing (10) in position. When tightening, hold the pump shaft to prevent it from turning.

Tightening torque:

Screw plug (12) 27 Nm

Tightening torques:

Impeller screw (11) 33 Nm

Oil pressure switch (15) 40 Nm

Water temperature sensor or

Screw plug (16) 9 Nm

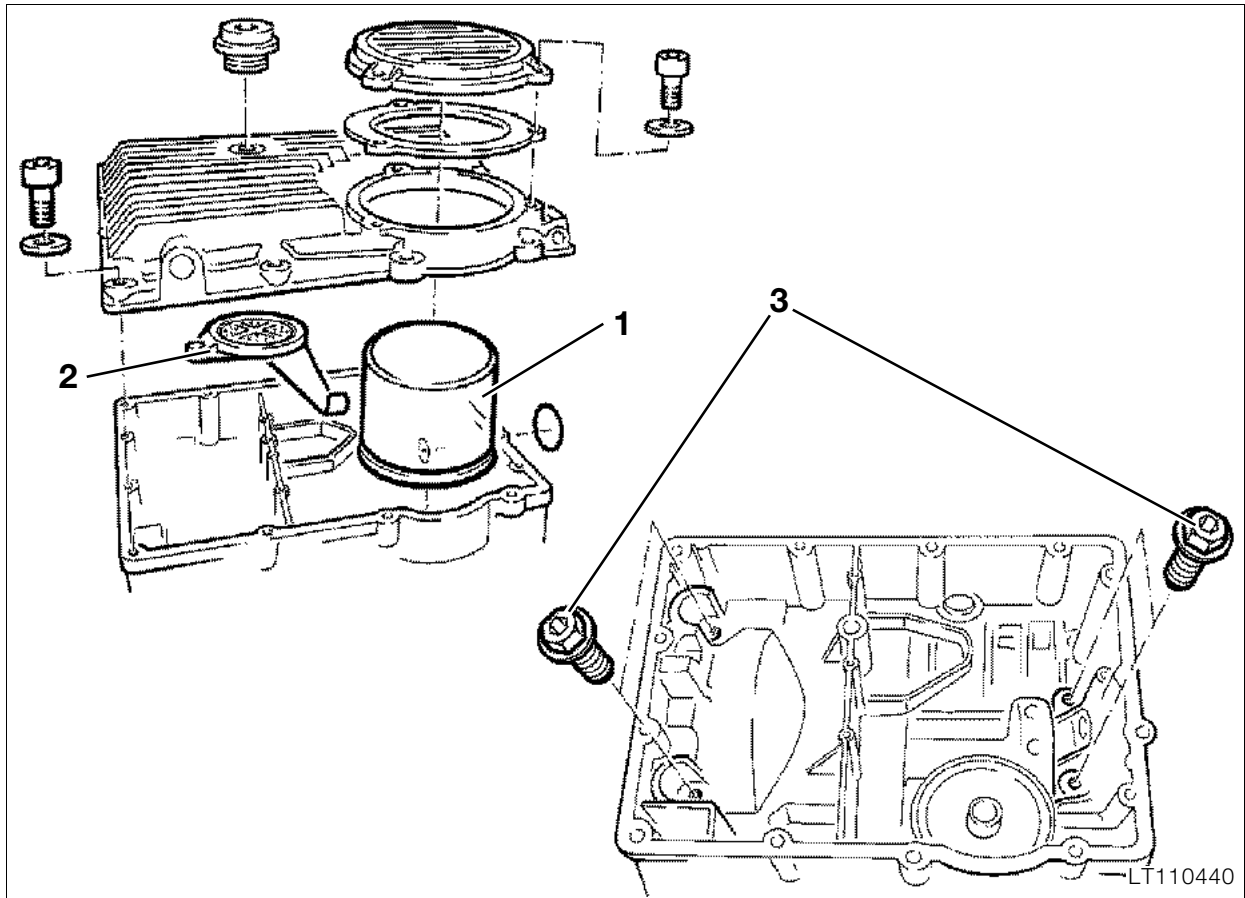

Removing output shaft

Removing oil sump

- After removing the screws, loosen the seal with light blows of a plastic-faced hammer.

Removing oil filter

- Unscrew oil filter (1) with the oil filter wrench, **BMW No. 11 4 650**.

Removing lower section of crankcase

- Take out retaining screws and screws (3) holding the output shaft.
- With light blows of a plastic-faced hammer, loosen the gasket and take off the lower section of the housing. Note presence of O-rings.
- Carefully lift out the output shaft; the needle roller bearing and circlip are loose on the shaft.

Removing and installing oil level sight glass

- Pierce the plastic disc with a large screwdriver and lever out the oil level sight glass.
- Oil the sealing face of the oil level sight glass lightly and drive it in with a drift,

BMW No. 00 5 550.

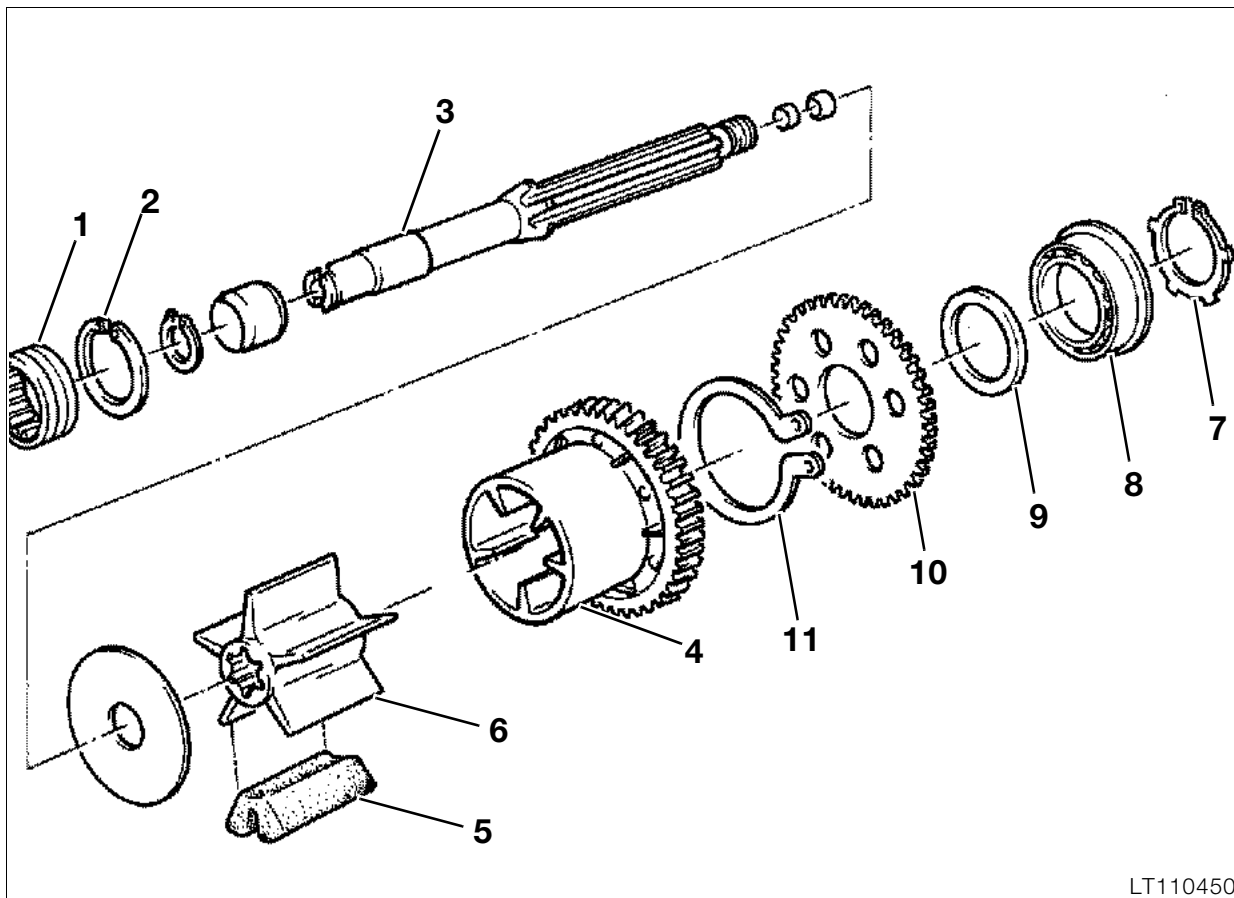
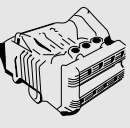

LT110450

Stripping and assembling output shaft

Stripping down output shaft

- Take off needle roller race (1) and circlip (2).
- Pull output shaft (3) out of damper housing (4).
- Drive the output shaft out of the inner section of the damper (5) with a plastic-faced hammer.

Stripping down tensioning gear

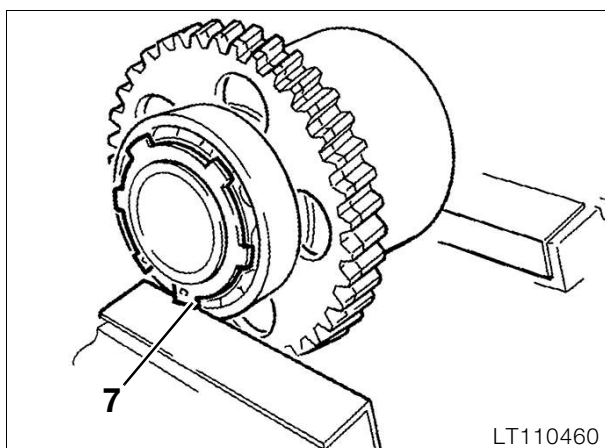

LT110460

- Remove circlip (7) with Seeger circlip pliers.
- Using two-arm puller, **BMW No. 00 8 400**, and thrust block, **BMW No. 33 1 307**, pull off ball bearing (8).
- Take off spacing ring (9).
- Remove tensioning gear (10) with counter-holder, **BMW No. 12 4 600**.
- Remove tensioning spring (11).



Note:

Inspect all parts for damage or wear.

- Clamp the damper housing into a vise with soft jaws, to take the load off circlip (7).

Assembling tensioning gear

- Insert the tensioning spring.
- Install tensioning gear with counter-holder, **BMW No. 12 4 600**.
- Clamp the tensioning gear with damper housing together into a vice with soft jaws.

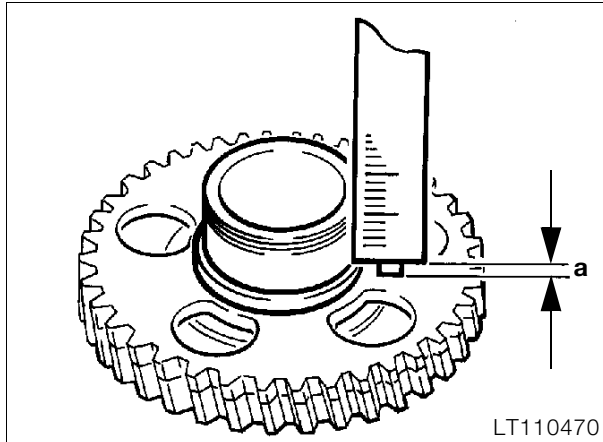

- Measure distance "a" from ball bearing seat to tensioning gear.

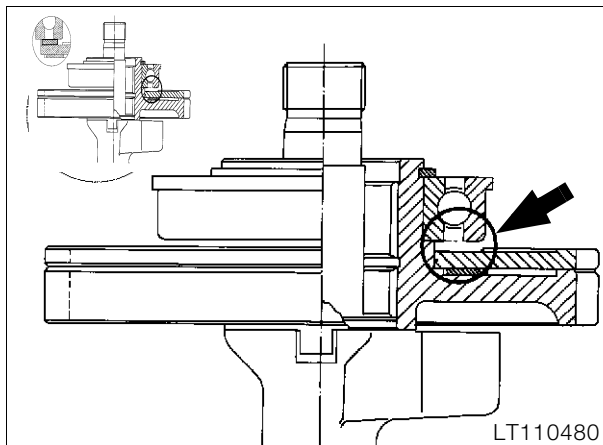

- Place a suitable spacing washer (arrow) on the tensioning gear.



Note:

The thickness of the spacing washer must never exceed this measurement.

- Heat the ball bearing to 80 °C and install it (with shoulder upwards).

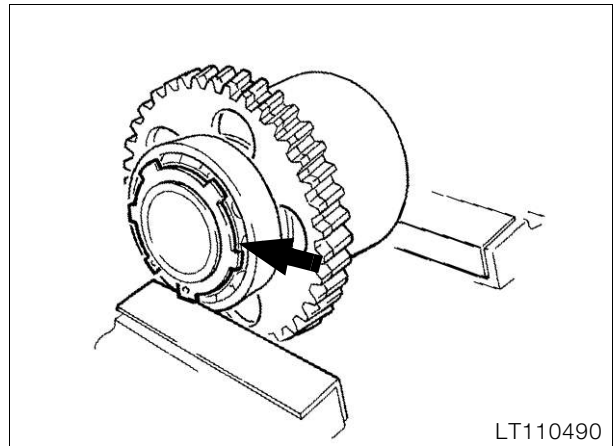

- Clamp the damper housing and the ball bearing together in the vice (with soft jaws).
- Place the circlip (arrow) in the groove in front of the bearing, using Seeger circlip pliers.
- The circlip must snap completely into the groove.

Installing damper

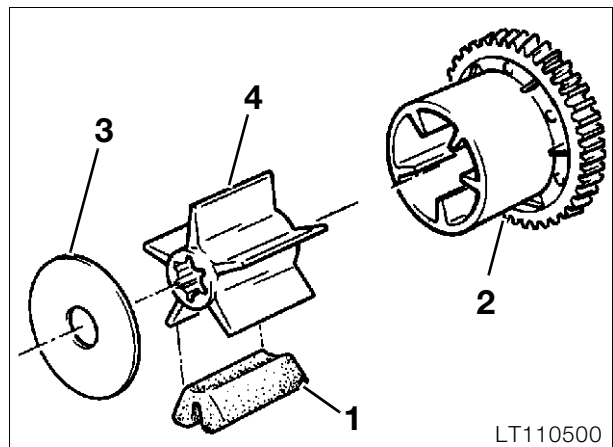

- Insert damper rubbers (1) into damper housing (2).
- Push retaining plate (3) on to output shaft; heat the inner section of damper (4) slightly and press it on.
- Push the damper housing on to the output shaft.

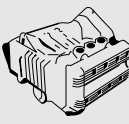

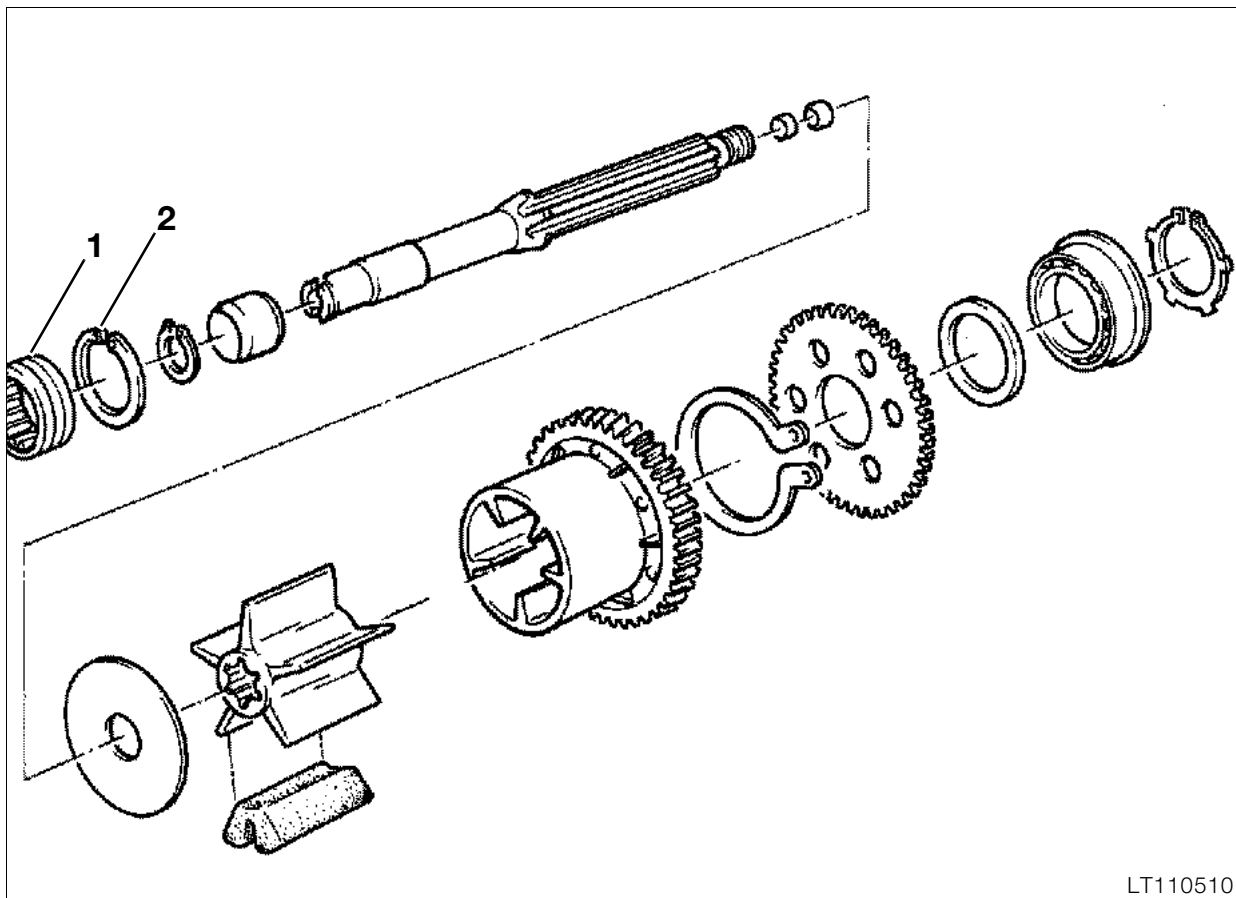
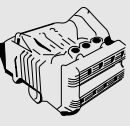

Assembling engine

Installing output shaft

- Push circlip (1) and needle roller sleeve (2) on to the bearing point.
- Place the output shaft in the crankcase.

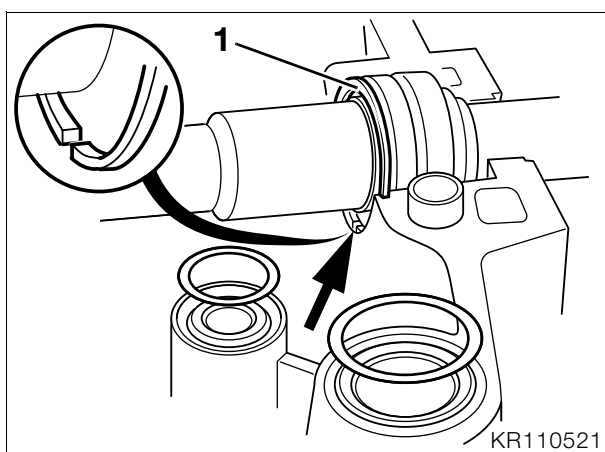

Note:

Gap of circlip (1) in crankcase (arrow).

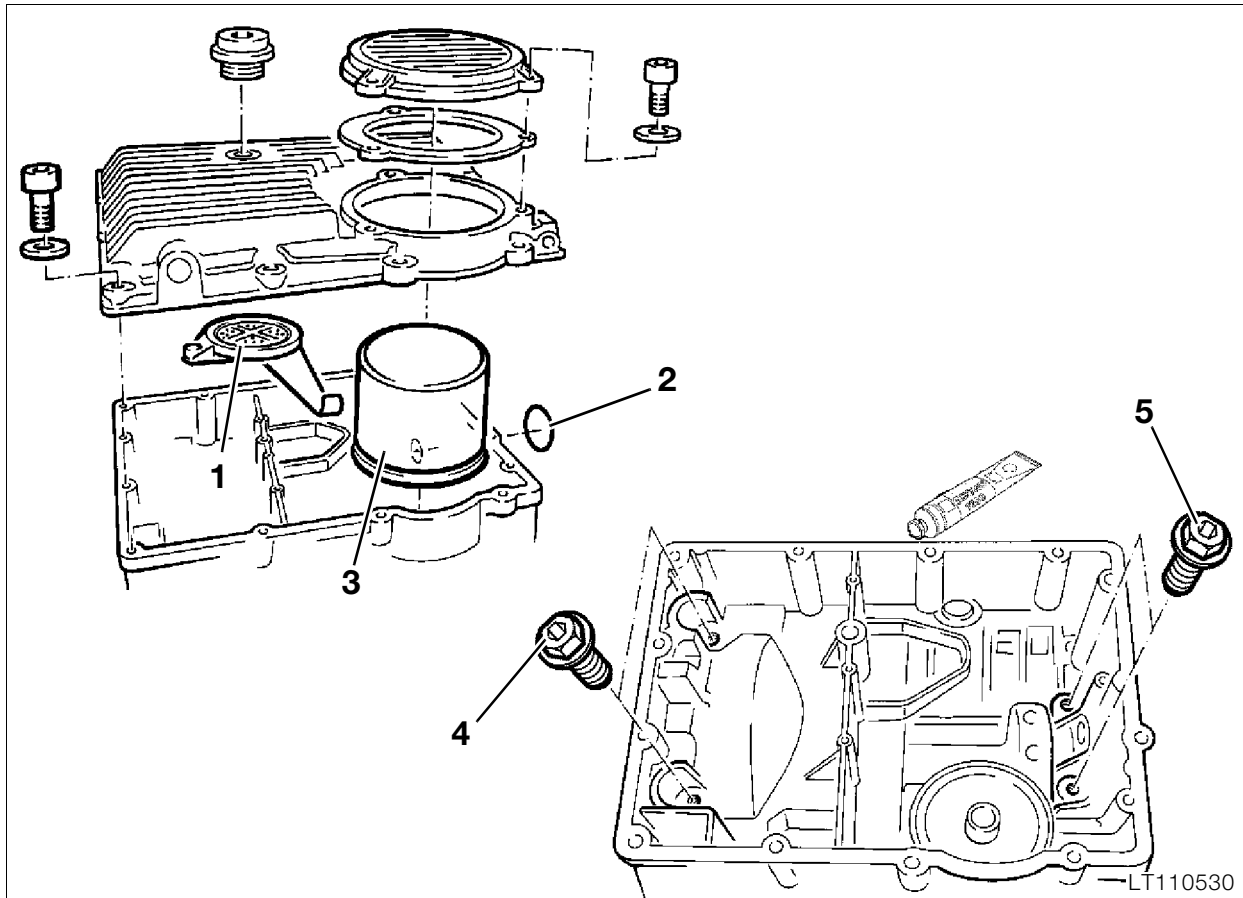

Assembling the crankcase

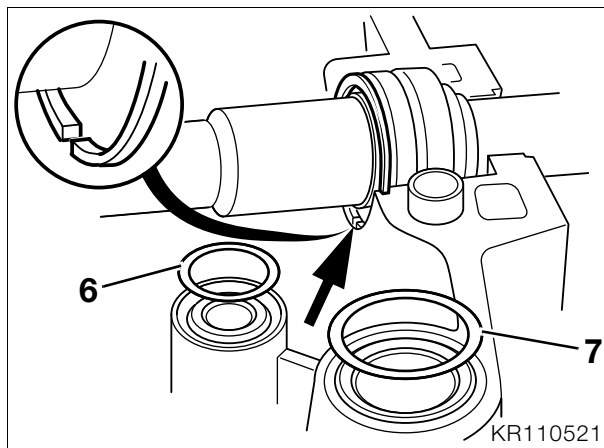

- Install O-rings (6,7) for the water and oil passages.
- Coat the sealing faces (which must be free from oil and grease) lightly with **3-Bond-1209**.
- Place the two halves of the housing together.
- Screw in bearing bolts (4, 5) for the shouldered and needle roller bearings, and tighten alternately.

Tightening torques:

Shouldered bearing (4)	40 Nm
Needle roller bearing (5)	18 Nm
Retaining screws of two halves of the housing	7 Nm

Installing oil mesh strainer

- Note presence of O-ring (2).

Installing oil filter

- Coat the oil filter sealing ring with oil.
- Do not tighten the oil filter more than half a turn beyond the point where it makes contact.

Installing oil sump

- Coat the sealing faces (which must be free from oil and grease) with **3-Bond 1209**.

Tightening torques:

Retaining screws	7 Nm
Oil filter	11 Nm

Measuring crankshaft bearing play

Measuring radial play

- Crankshaft bearing points must be clean and lightly oiled.
- Place the crankshaft in the crankcase and install the bearing caps so that the joint lines are aligned.



Note:

Bearing caps 1...3 are marked; bearings 4 (thrust bearing) and 5 are not marked.

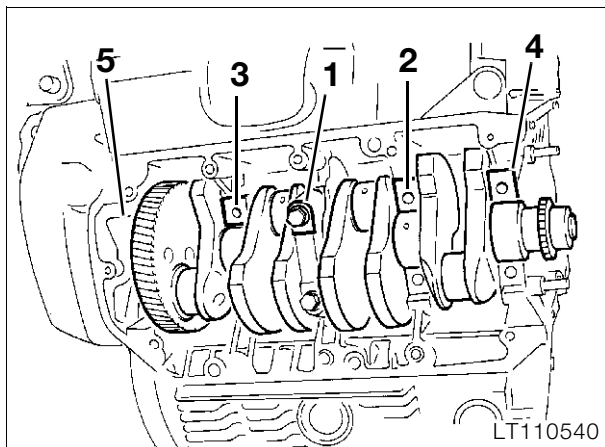
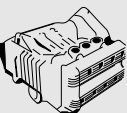

- Tighten the bearings in the order shown, starting from the centre and working outwards.



Tightening torque:

Main bearings 50 Nm

- Turn the crankshaft to top dead centre at the bearing to be measured.
- Take off the bearing cap.
- Turn the crankshaft further by approximately another 30°.
- Wipe off oil at the bearing journal and bearing shell.

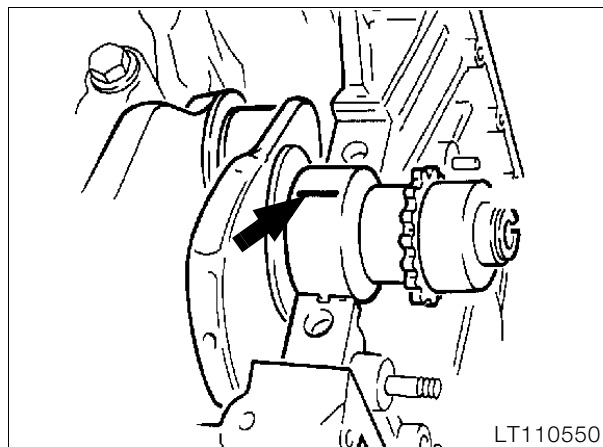

- Measure bearing play with Plastigage Type Pg-1, **BMW No. 00 2 590**.
- Place the Plastigage strip (arrow) over the entire width of the bearing, 6...8 mm (0.24...0.32 in) from the centre.



Tightening torque:

Main bearings 50 Nm



Note:

Do not turn the crankshaft any more.

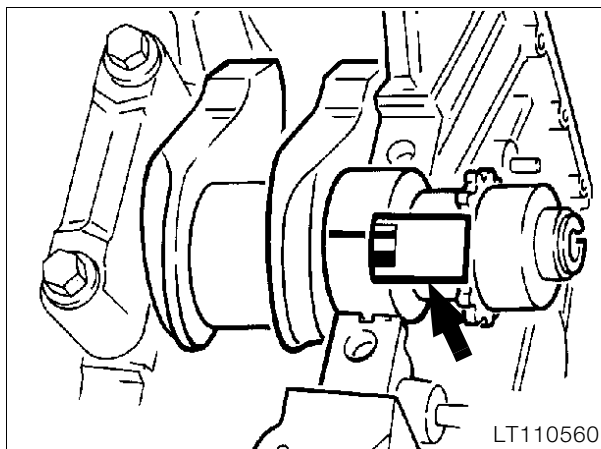

- Remove bearing cap.
- Determine the width of the strip and thus the bearing play with the comparison scale (arrow).

Radial

clearance 0.020...0.056 mm (0.0008...0.0022 in)

Wear limit 0.110 mm (0.0043 in)

Measuring endplay

- Install the crankshaft and measure as for radial play.

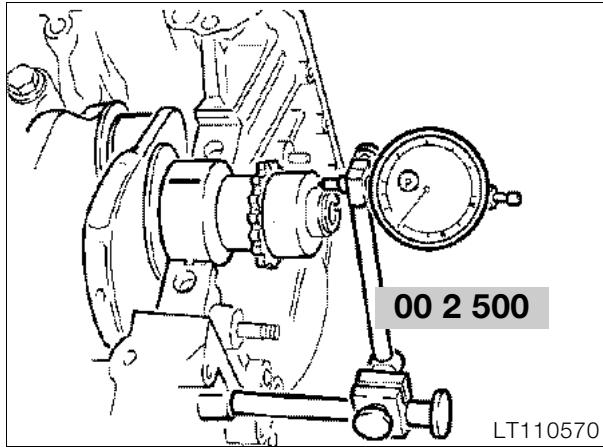

- Screw measuring fixture, **BMW No. 00 2 500**, with dial gauge into the tapped hole for the timing case cover.
- Move the crankshaft from one limit to the other and take the dial gauge reading.

Axial play..... 0.080...0.183 mm (0.0031...0.0072 in)
Wear limit 0.250 mm (0.0098 in)

Checking dimensions of crankshaft

- If measured bearing play was too large, the dimensions of the crankshaft must be checked. Regrinding stages "0" and "1" are available; the crankshaft is marked with the appropriate number of paint spots at the bearing point. If there are no paint spots, this indicates regrinding stage "0".

Crankshaft dimensions..... see Technical Data

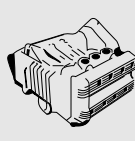

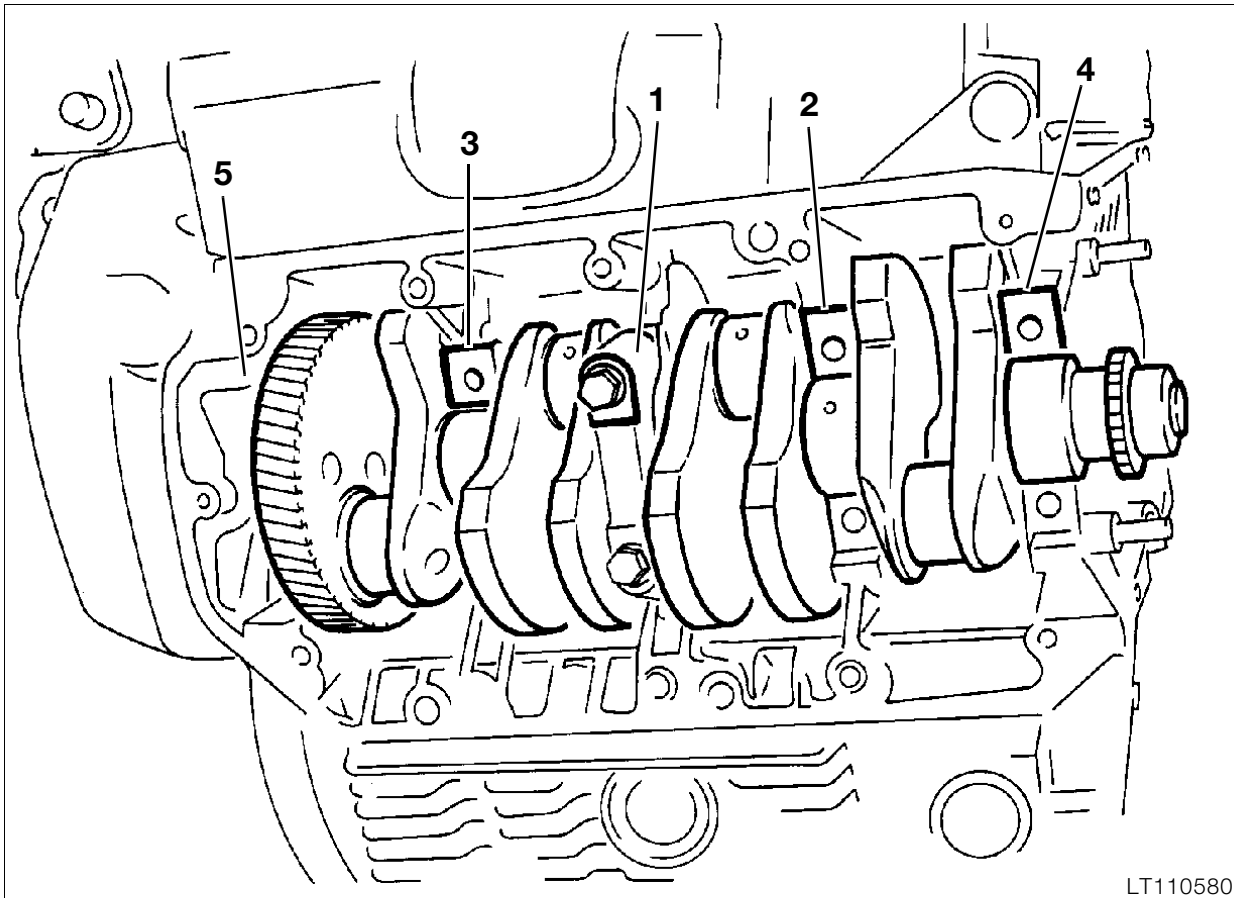
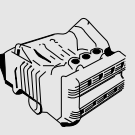

LT110580

Installing crankshaft

- Oil the bearings lightly before inserting the crankshaft.
- Install the corresponding bearing caps with the grooves aligned.



Note:

Bearing caps 1...3 are marked for identification; bearing caps 4 (thrust bearing) and 5 are not marked.

- Tighten the bearings in the order shown, starting from the centre and working outwards.



Tightening torque:

Main bearings 50 Nm

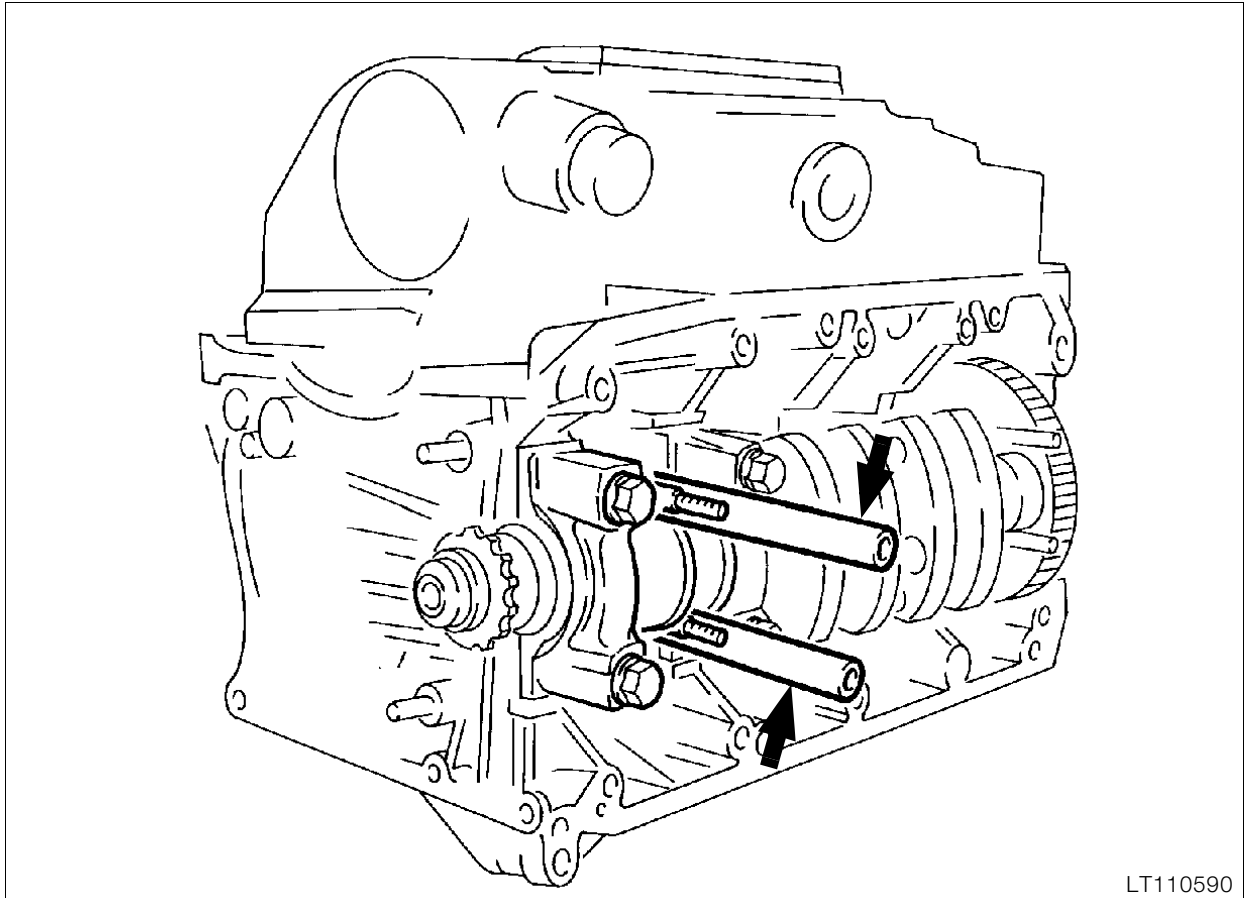

LT110590

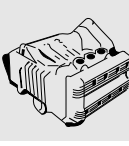

Installing piston with conrod

- Turn the corresponding crankpin to bottom dead centre.
- The piston ring gaps must be offset by app. 120° in each case.



Note:

The gap of the micro-chamfer ring in groove 2 is determined by the pin.

- Oil the piston rings, piston skirt and cylinder wall thoroughly.

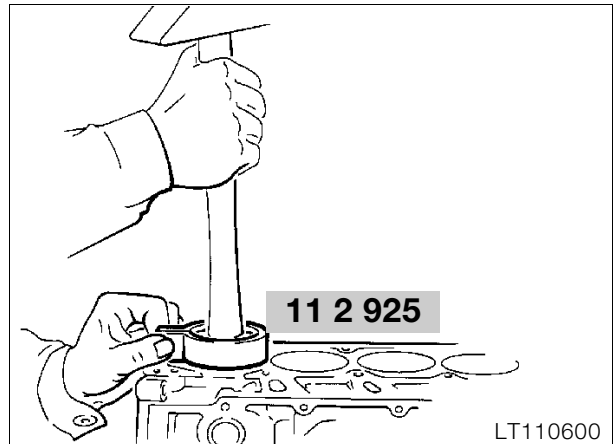

LT110600

- Using tensioning strap, **BMW No. 11 2 925**, compress the piston rings.
- Insert the piston with conrod into the cylinder.
- Drive the piston carefully into the cylinder with a hammer handle.
- The arrow on the piston crown must point towards the timing end of the engine (cyl. 1).
- Make sure that the pistons are in the same weight category.

Measuring big end bearing play

- Turn the crankpin 30° away from bottom dead centre.
- Wipe oil off crankpin and bearing cap.

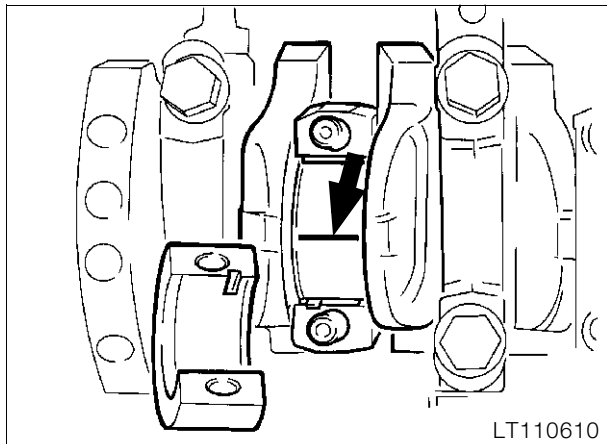

- Place Plastigage strip (arrow), Type PG-1, **BMW No. 00 2 590**, over the entire width of the bearing, 6...8 mm (0.24...0.32 in) away from the centre of the crankpin.
- Attach the bearing caps with the joint lines aligned, and tighten them.

Tightening torque:
Big end bearings 30 Nm

Note:
The crankshaft must not be turned any more at this stage.

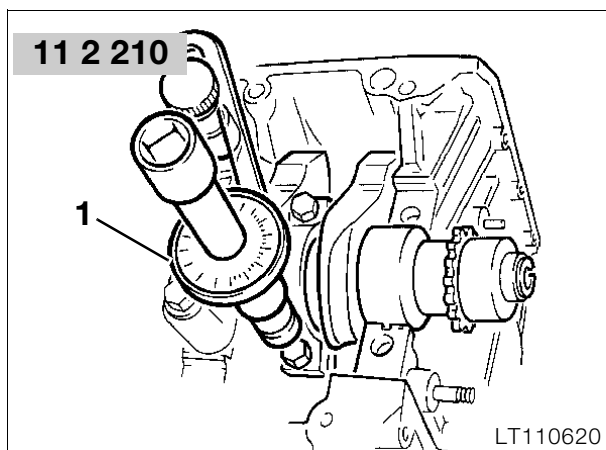

- Tighten the big end bearings with wrench angle indicator (1), **BMW No. 11 2 210**.

Tightening torque:
Wrench angle 80°

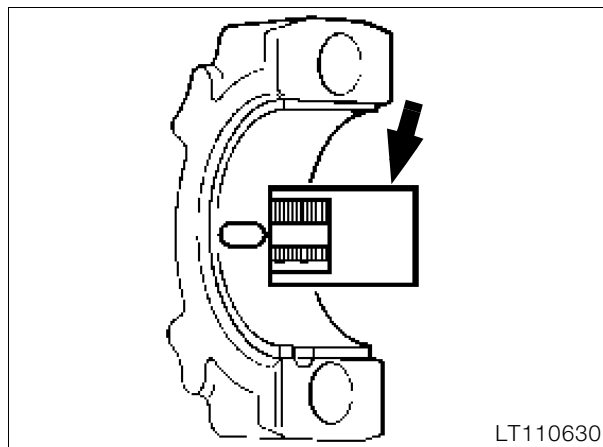

- Unscrew and remove the bearing cap.
- Determine bearing play against comparison scale (arrow).

Bearing
play 0.030...0.066 mm (0.0012...0.0026 in)
Wear limit 0.130 mm (0.0051 in)

- If bearing shells are renewed, note paint marks on crankpin and on big end bearing.
- Regrinding stages "0" and "1" are available; the crankpins are marked with a corresponding number of paint spots.
- If there are no paint spots, this indicates regrinding stage "0".

Note:
The crankshaft can only be reground in stage "0", and must be hardened and finished afterwards.

Installing big end bearing

- Move the crankpin of the cylinder concerned to bottom dead centre.
- Oil the crankpin and attach the conrod.
- Pull the protective tubes off the bolts.
- Attach the bearing caps with the joint lines aligned, and tighten them.

Tightening torque:
Big end bearings 30 Nm

- Using wrench angle indicator, **BMW No. 11 2 500**, tighten the big end bearing.

Tightening torque:
Wrench angle 80°

Installing combined oil-water pump

- Apply a thin coat of **3-Bond 1209** to the sealing faces, which must be free of oil and grease.
- Place O-ring on water passage.
- Insert the input pinion into the output shaft with an oiled O-ring.
- Attach the pump housing and insert the screws loosely at first.



Note:

Turn the crankshaft several times in order to centre the gearwheels, at the same time gradually tightening the retaining screws.

- Tighten the retaining screws fully.



Tightening torque:

Pump housing to crankcase..... 7 Nm

- Insert the wire for the oil pressure telltale and temperature display through the housing and connect it.
- Apply a thin coat of **3-Bond** to the sealing faces on the cover and housing, which must be free from oil and grease.
- Place the housing cover in position and tighten it.



Tightening torque:

Cover to pump housing..... 7 Nm

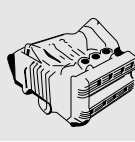

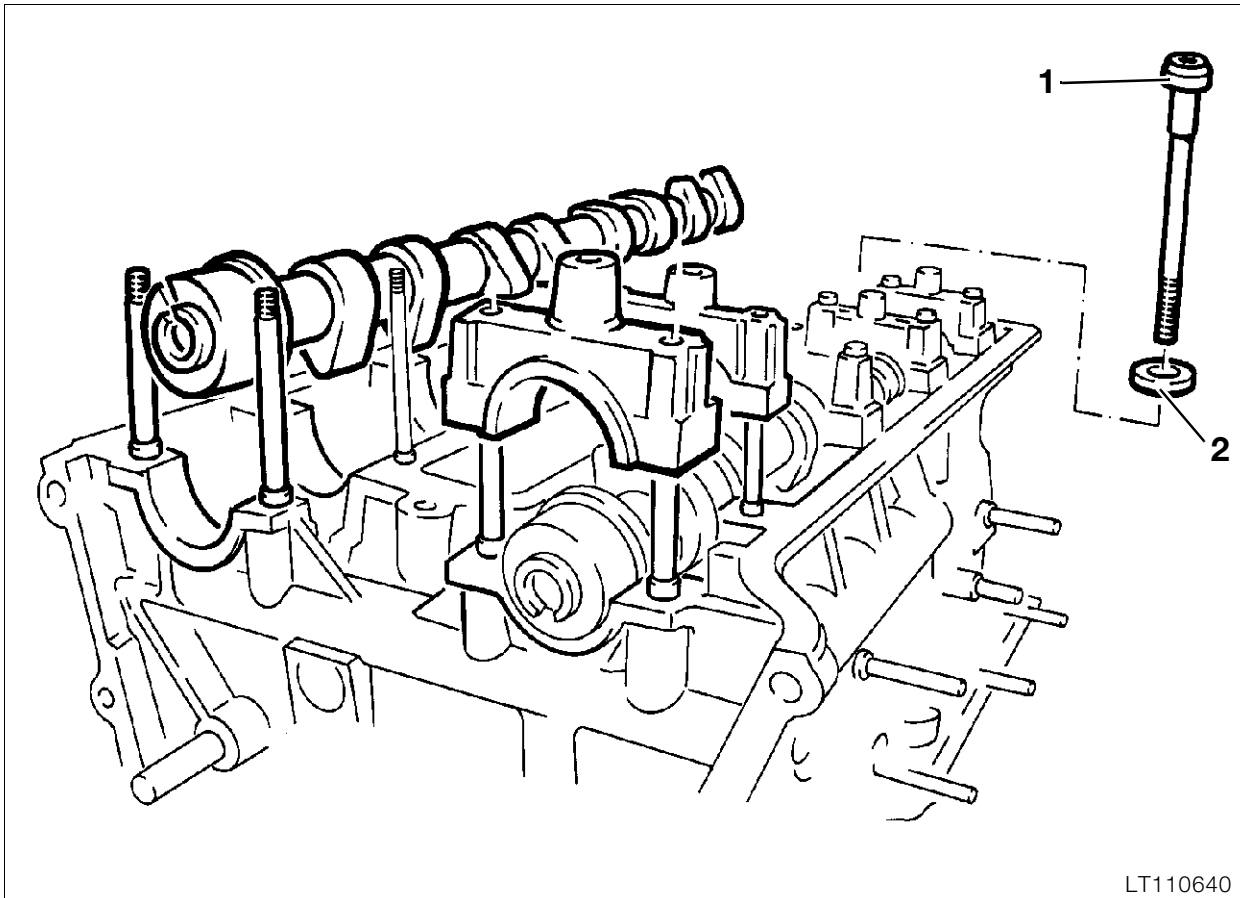
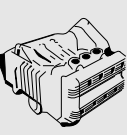

Installing cylinder head

- Move the piston in cylinder 1 to top dead centre (cylinder 1 = timing end).
- Place the cylinder head gasket in position; no holes or passages must be obstructed.



Note:

Use only cylinder head bolts with long thread [from 12/94].

- Place the cylinder head in position and insert bolts (1) with washers (2) as far as possible.

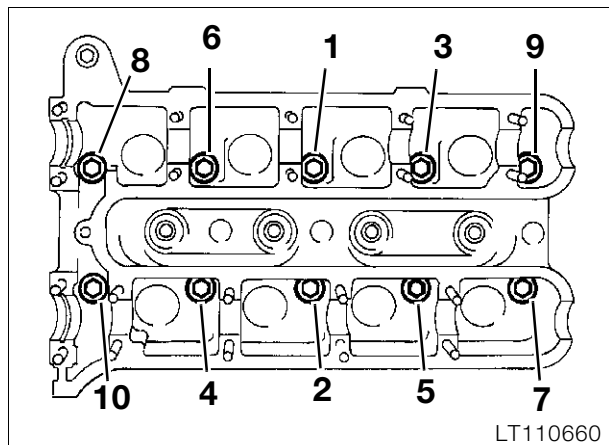

- Tighten the cylinder head bolts in the order shown.



Tightening torque:

Cylinder head bolts 20 Nm

- Attach tighten angle measuring device, **BMW No. 11 2 500**, using two T 50 Torx inserts, **BMW No. 00 2 630**.
- Tighten the cylinder head bolts, to the specified torque and angle, as specified.

Tightening angle..... 90°

Installing camshafts



Note:

Note correct identification of camshafts.

Inlet side : three grooves after thrust bearing
Exhaust side: two grooves after thrust bearing

- The camshaft bearing caps are also marked.

Inlet side: odd numbers
Exhaust side: even numbers

- The numbers increase from the front (timing end) to the rear.
- Oil the camshafts at their bearing points.
- Tighten the bearing caps uniformly, working from the inside outwards.
- Install the thrust bearing (timing end) with chain guide last of all.

**Tightening torque:**

Bearing cap..... 9 Nm

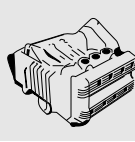

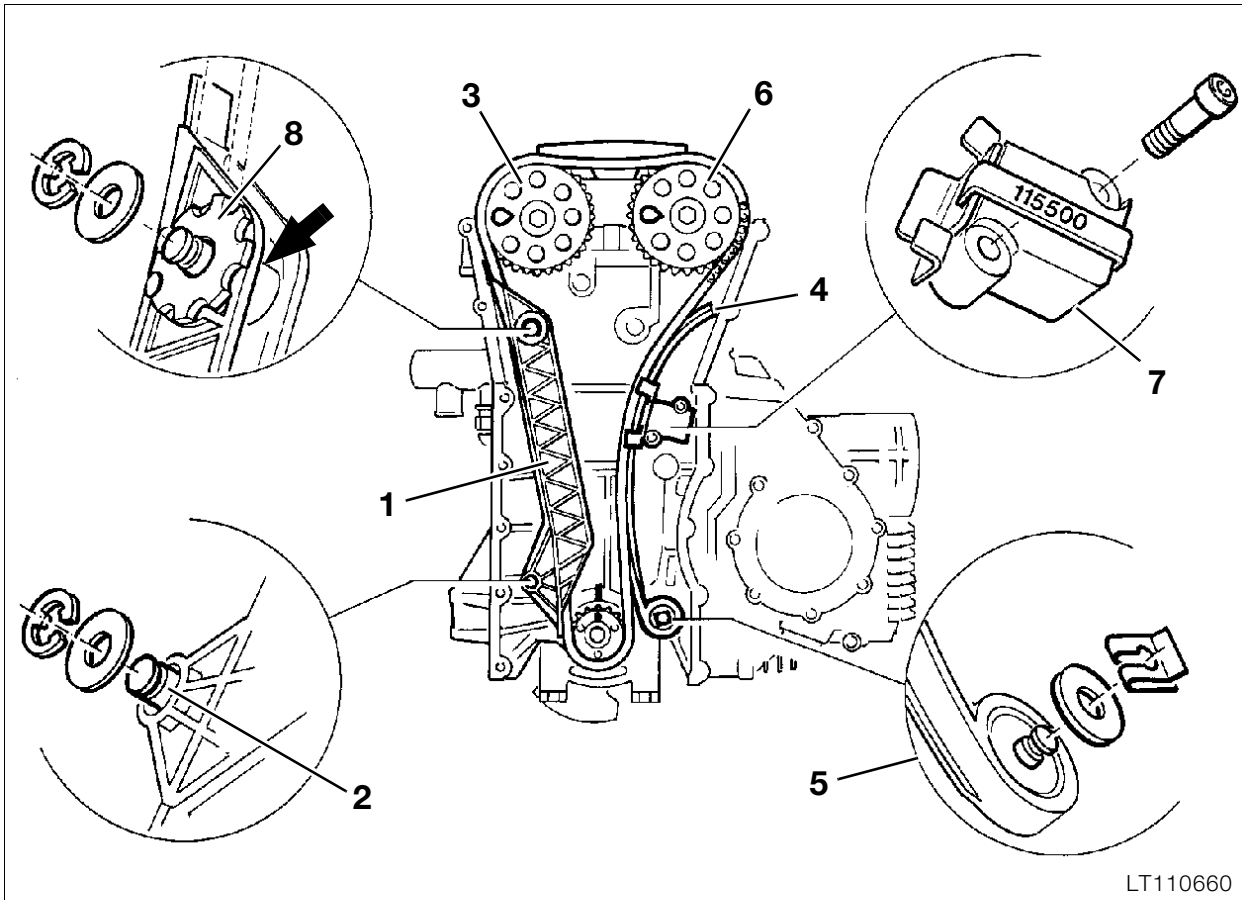

LT110660

Installing timing chain

- Turn the camshaft so that the grooves on the ends are vertical in relation to the cylinder head at the rear.
- The grooves at the front end must point towards the crankshaft.

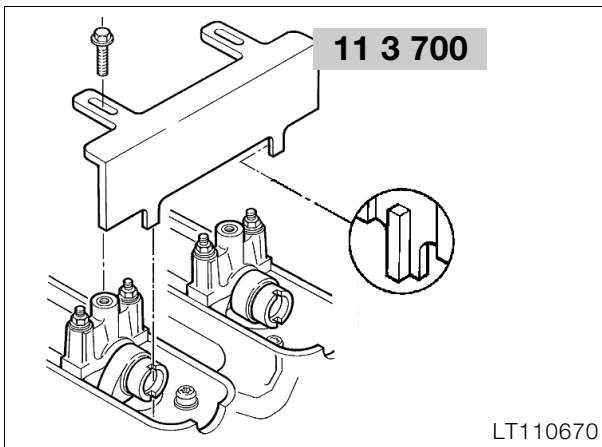

- Insert adjusting tool, **BMW No. 11 3 700**, and attach it to the camshaft bearings.
- Place the timing chain in guide rail (1) and press in spacing bushing (arrow).

- Place the timing chain round the crankshaft chain sprocket and press the guide rail on to the pivot pin.
- Secure the guide rail at the lower pivot pin (2) with the washer and clip.
- Install chain sprocket (3) for the inlet camshaft so that the timing chain is pulled taut towards the guide rail.
- Insert the retaining screw as far as possible.
- Press tensioning rail (4) on to the pivot pin and secure with the large washer and clip (5).
- Install chain sprocket (6) for the exhaust camshaft so that the timing chain is as taut as possible between the chain sprockets.
- Insert the retaining screw as far as possible.
- Using tensioning tool, **BMW No. 11 5 500**, install chain tensioner (7) and secure.

Tightening torque:

Chain tensioner 9 Nm

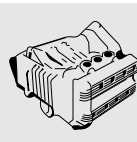
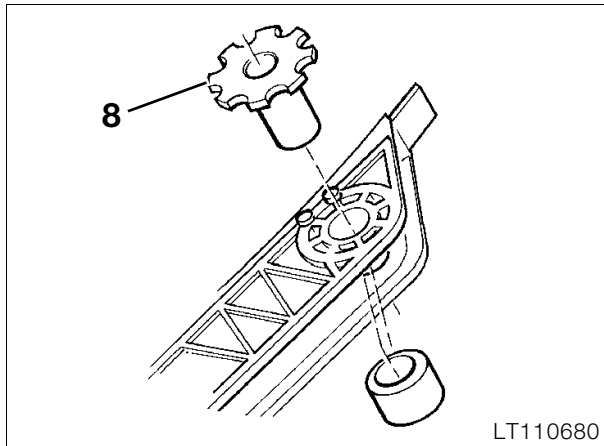

- Press serrated washer (8) with eccentric shoulder into the chain guide rail spacing bushing by a small amount.
- Turn the serrated washer until the guide rail is touching the outer edge of the cylinder head.
- Press the serrated washer in fully and allow it to engage at the two pins.
- Secure the serrated washer with the small washer and clip.
- Remove the special tool.
- Tighten the chain sprockets, holding the hexagon on the camshaft to prevent it from turning.



Tightening torque:

Chain sprocket..... 54 Nm

Checking valve clearances

- Turn the engine over at the crankshaft (counterclockwise).
- Measure valve clearance with feeler gauge.

Valve clearances:

Inlet..... 0.15...0.20 mm (0.006...0.008 in)
 Exhaust..... 0.25...0.30 mm (0.010...0.012 in)

- If the valve clearance has to be corrected, remove the timing chain and camshaft again.
- Renew the bucket tappets.

Installing intermediate flange

Installing freewheel

- Insert the freewheel into the crankcase with the helical-cut gearwheel leading.
- Oil the needle roller bearing well.

Installing countershaft

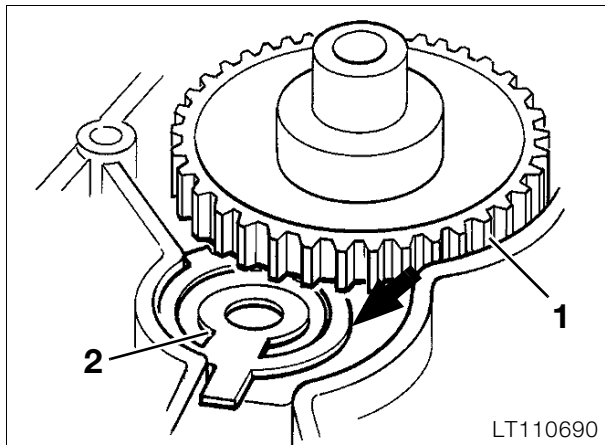

- Insert countershaft (1) into the crankcase with the small gearwheel facing downwards.
- Insert spring (2) with the larger external diameter (arrow) projecting upwards and located behind the freewheel gear.

Installing intermediate flange

- Apply a thin coat of **3-Bond 1209** to the sealing faces, which must be free from oil and grease.
- Attach the intermediate flange (with all collets in position).
- Tighten screws with Torx insert, **BMW No. 00 2 600**.

 **Tightening torque:**
Intermediate flange..... 9 Nm



Note:

Note rubber filler in the starter motor area.

Installing driver

- Clean tapped hole and screw (must be free from grease).
- Push driver on to layshaft.
- Secure retaining screw with **Loctite 273 FL**.



Tightening torque:

Driver 33 Nm

Installing alternator

- Install the alternator with the damping rubber.



Tightening torque:

Alternator 22 Nm

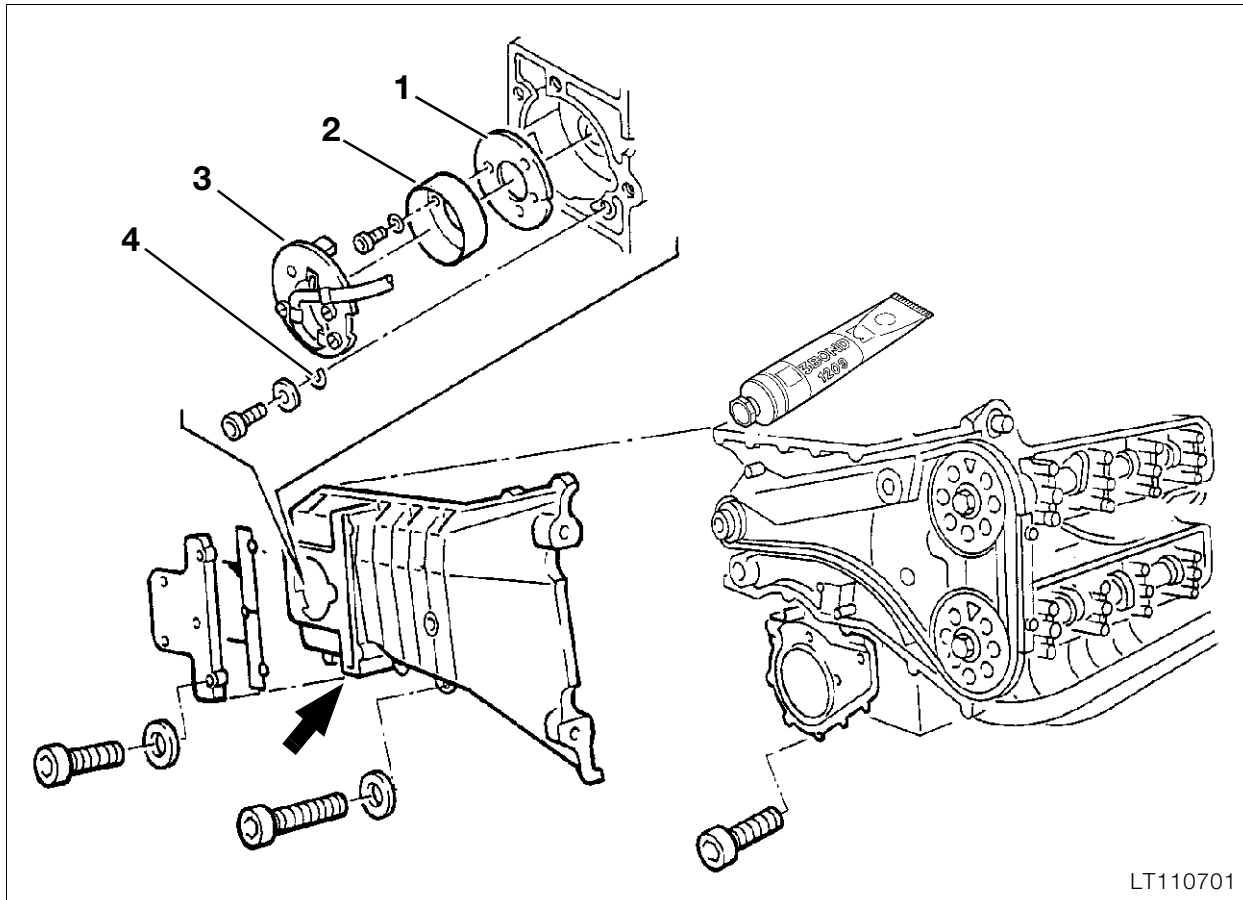

LT110701

Installing timing case cover

- Apply a thin coat of **3-Bond 1209** to the sealing faces, which must be free from oil and grease.
- Pass the wires for the telltale lights (oil pressure, coolant temperature) through the cable duct (arrow).
- Place the timing case cover in position and tighten it.

 **Tightening torque:**
Timing case cover 7 Nm

Installing hall-effect transmitter

- Screw adjusting disc (1) and gate rotor (2) to the crankshaft.

 **Tightening torque:**
Gate rotor 2.5 Nm

- Insert baseplate (3) for Hall-effect transmitter.
- The cutouts in the baseplate and timing case cover should coincide.
- Insert the retaining screws with shim washer and semi-circular washer (4).

 **Tightening torque:**
Baseplate 6 Nm

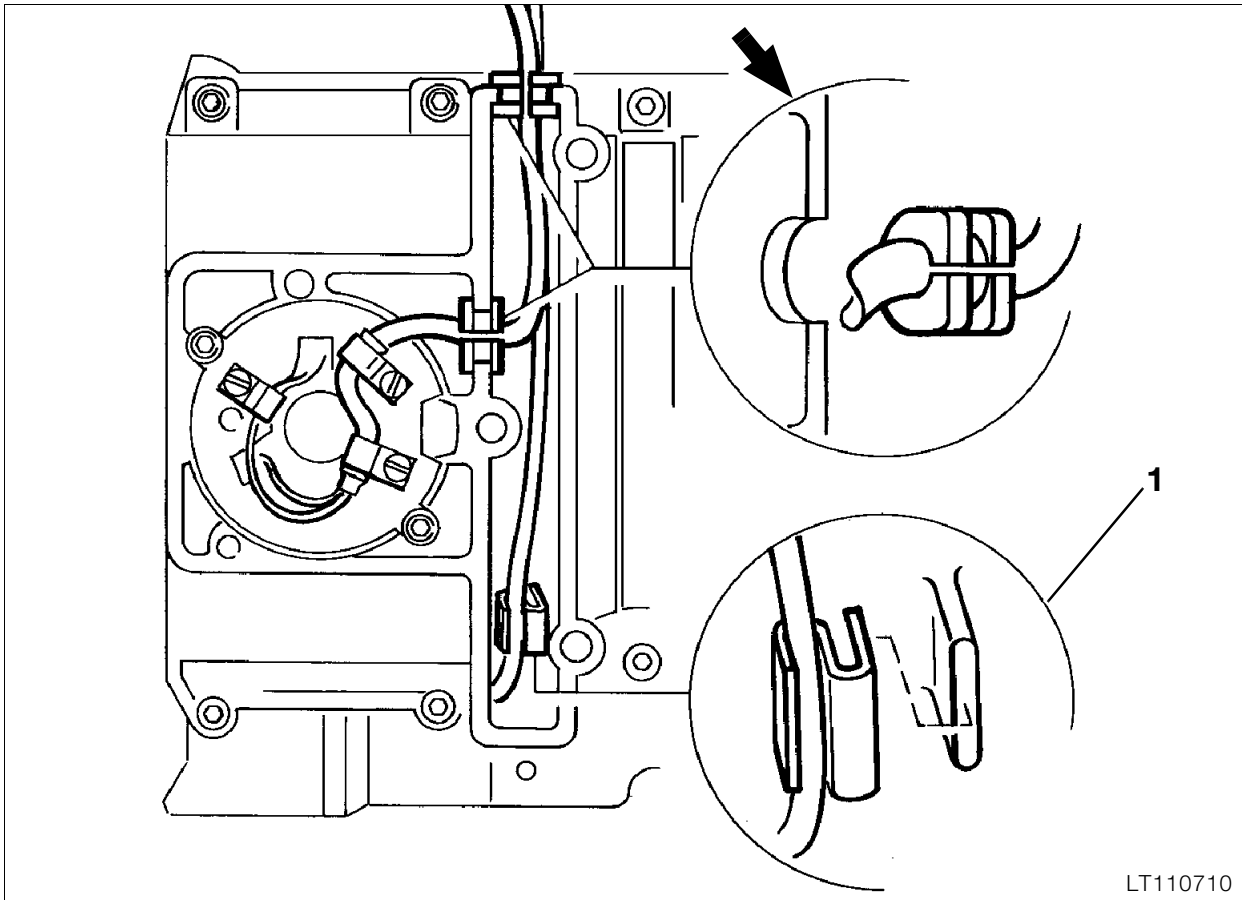
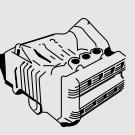

LT110710

Installing cover for Hall-effect transmitter

- Install the wire for the Hall-effect transmitter with rubber grommet (arrow) in the timing case cover.
- Secure the wire for the oil pressure telltale and coolant temperature with clip (1).
- Install cover with cork gasket.



Tightening torque:

Cover 6 Nm

Installing cylinder head cover

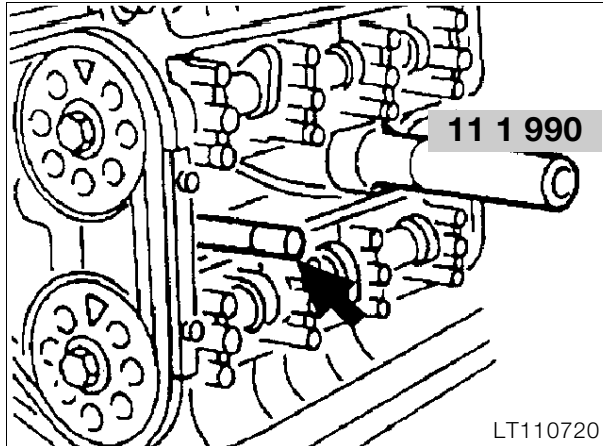

- Insert reamed bolt (arrow), **BMW No. 11 1 980**, into inner front hole.
- Press centering pin, **BMW No. 00 5 500**, into mount under the third camshaft bearing.

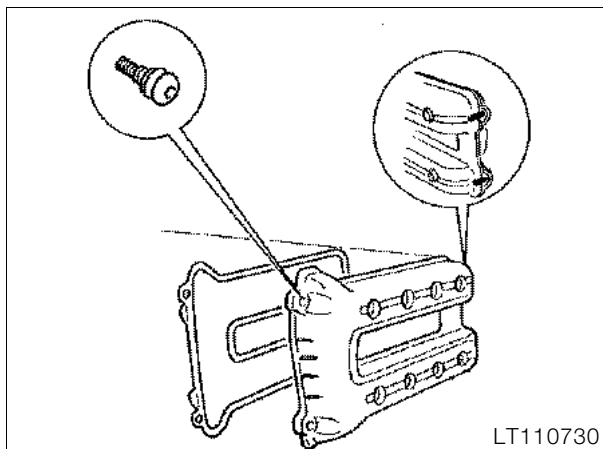

- Install the cylinder head cover gasket with the half-moon cutouts first. The marks at the front and rear of the gasket and the cylinder head cover must coincide.
- Oil the gasket and half-moons lightly.
- Press in the half-moon on the gearbox side first.
- Apply a small amount of **3-Bond 1209** to the joint area of the cylinder head and timing case cover.
- Attach the cylinder head cover with gasket.

- Insert all retaining screws as far as possible.
- Tighten the retaining screws in a crosswise pattern, working from the inside outwards.

Tightening torque:

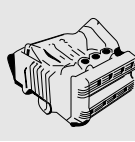

Cylinder head cover 8 Nm

- Take out the reamed and centering screw and insert the remaining retaining screws.

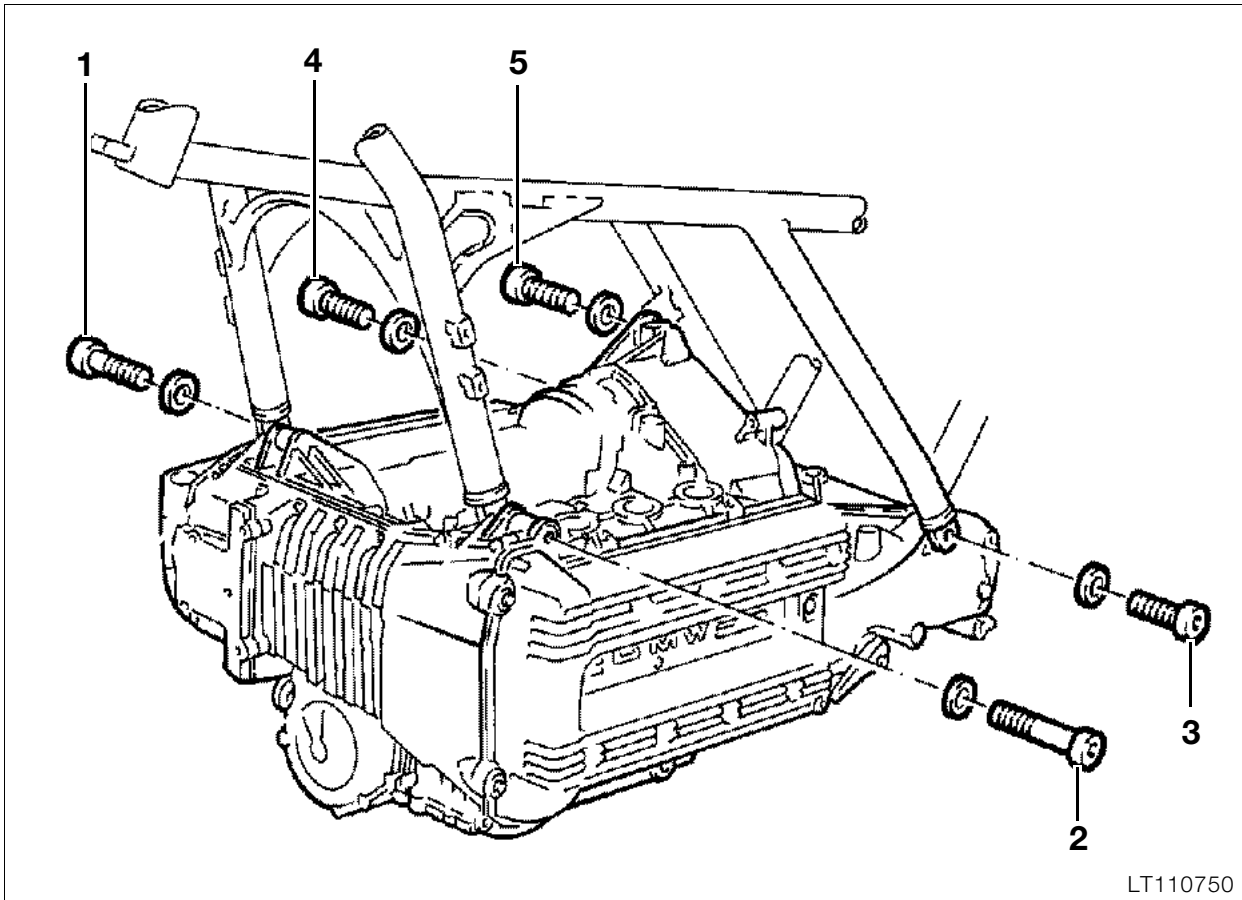



Installing engine

- Attach hoist, **BMW No. 00 1 510**, to the oil sump.
 - Set the engine down on the hoist platform.
 - Release the engine mounting at the engine block.
 - Install the throttle rail.
 - Install the inner bulkhead at the cylinder (3).
 - Install the lower section of the air cleaner housing.
 - Install the fuel return line with pressure regulator.
 - Connect the crankcase breather.
 - Position the frame with telescopic fork and frame support over the engine.
 - Bolt the engine and driveline together.
-  **Tightening torque:**
 Gearbox to intermediate flange 16 Nm
- Bolt the engine and frame together in the order stated here:
 1. Insert all 5 bolts loosely but do not screw them fully in. Insert a 1 mm thick spacing washer at the front right, between the cylinder head and frame strut, and a support washer on the inside.
 2. Tighten bolts 1, 4 and 3.
 3. Shim to the correct thickness at the front left and install the support washer on the outside, then tighten the bolt.
 4. Shim the attachment point at the intermediate flange and tighten the bolt.
-  **Tightening torque:**
 Frame to engine 45 Nm
- Install fuel injection rail.
-  **Tightening torque:**
 Fuel injection rail 7 Nm

- Connect the engine wiring harness (coolant stub pipe, throttle position sensor, CO detector, injectors, air cleaner housing).
- Attach cable straps (three) at fuel injection rail.
- Attach wire cables for increased idle speed and throttle operation.

Throttle cable play..... 0.75 mm (0.03 in)

- Install the radiator.

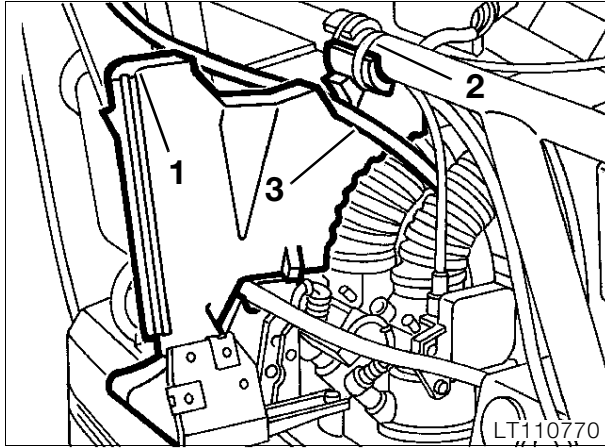

- Install the left engine bulkhead (1).
- Attach cable strap (2).
- Install fuel line (3).

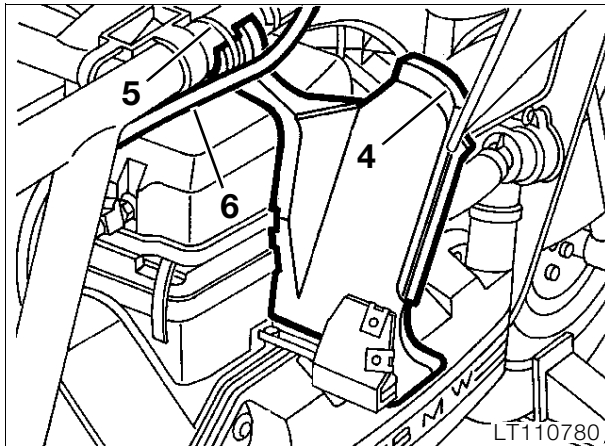

- Install right engine bulkhead (4).
- Attach cable strap (5).
- Install coolant line (6) in bulkhead.
- Install driveline.
- Install fuel tank.
- Install radiator surround.
- Install left and right side sections.
- Install storage compartment.
- Install knee pads.

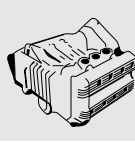

Checking/adjusting valve clearances



Caution:

Never unscrew the spark plugs before measuring valve clearances. Particles of oily soot could become lodged behind an exhaust valve head and falsify the measurement.

- Remove left side section of fairing.
- Remove the cylinder head cover.
- Remove cover for Hall-effect transmitter.
- Turn the engine only at the crankshaft (direction of rotation: anti-clockwise).
- Measure valve clearance with feeler gauge.
- Max. engine temperature 35 °C.
- Determine size of replacement tappets by comparing desired and actual measurements.

Valve clearances:

Inlet 0.15...0.20 mm (0.006...0.008 in)
 Exhaust 0.25...0.30 mm (0.010...0.012 in)

Adjusting valve clearances

- The camshaft must be removed before the bucket tappets can be renewed.
- Set cylinder 1 (timing end) to top dead centre on the ignition stroke.

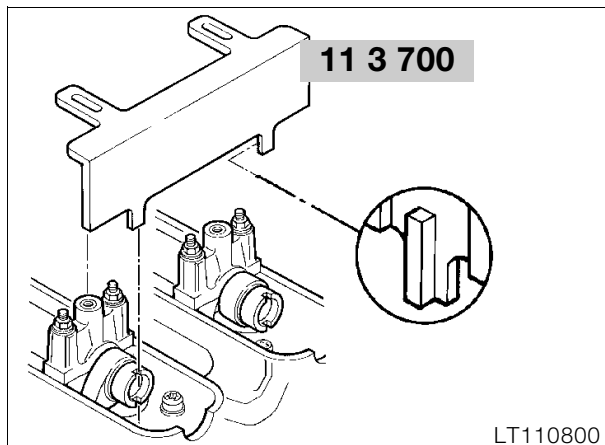

- The adjusting device for the camshafts, **BMW No. 11 3 700**, must enter the slots at the end of the shafts.
- Remove the screw plug in the timing case cover.

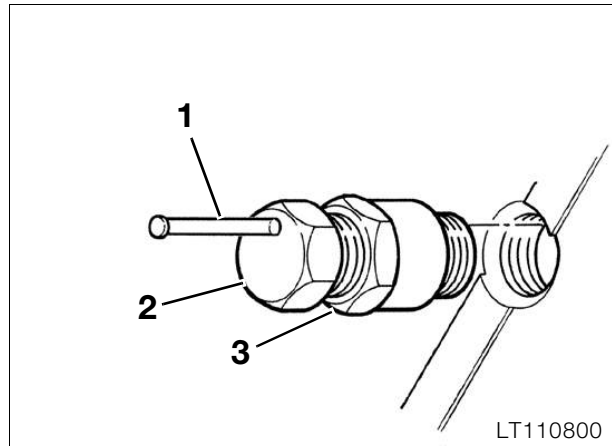

- Hold the chain tensioner and timing chain with eccentric tensioner, **BMW No. 11 2 640**.
- Pull back tensioning pin (1) and screw in eccentric (2) by 3...4 turns.
- Push the tensioning pin forward above the timing chain.
- Turn the eccentric slightly to the right to locate the timing chain and chain tensioner.
- Secure the eccentric with locknut (3).
- Remove the chain sprockets.
- Remove the camshafts.
- Renew the bucket tappets as necessary.
- Assemble in the reverse order of work.

12 Engine electrics

Contents

Page

Technical data	3
Removing and installing Hall generator	5
Adjusting ignition timing	6
Removing and installing ignition coils	8
Removing and installing ignition output stage	9
Removing and installing alternator	10
Disassembling and assembling alternator	11
Alternator [only LT up to 1992 model year]	11
Checking exciter winding	12
Checking armature for short to earth	13
Checking resistance between phase outputs	13
Checking stator winding for short to earth	13
Alternator [LT from 1992 model year on, RS]	14
Checking alternator	15
Checking armature for short to earth	15
Removing and installing starter	16
Disassembling and assembling starter	17
Removing and installing brush holder	18
Renewing carbon brushes	19
Checking starter	20
Checking starter relay	21
Checking starter relay with ohmmeter	21
Troubleshooting	22
Troubleshooting on alternator	22
Troubleshooting on starter	26
Troubleshooting on battery	29

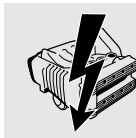



Technical data		K 1100 LT	K 1100 RS
Starter			
Type		Permanent magnet motor	
Gear ratio		27 : 1	
Output	kW	0,7	
Alternator			
Type		Three-phase alternator with integrated fully electronic regulator	
Drive		direct, gear ratio 1 : 1.5	
Maximum output	W/V	460/14 / – 700/14 from Mod.93	
Max. current	A	33/ – 50 Mod.93	
Charge cut-in	rpm	950 ± 50	
Max. speed	rpm	12 300/ – 20 00 from Mod.93	
Spark plugs			
Bosch		XR 5 DC	
Beru		12R-5 DU	
Electrode gap	mm (in)	0.6 (0.2362) + 0.1(0.0039), wear limit 0,9 (0.0354)	
Thread	metric	M 12 x 1.25	
Ignition			
Ignition system		Motronic (mapped ignition timing control)	
Ignition pulse trigger		Two magnetic barriers (Hall generator) secured on the crankshaf	
Ignition timing adjustment, static	°KW	6 vor OT= 0,24 mm (0,00945 in)	
Max. advanced ignition	°KW	31	
Max. ignition control	°KW	25	
Control start	rpm	1 500	
Control end	rpm	8 650	
Speed limitation	rpm	8 980	
Ignition coil			
Double ignition coil, make Bosch			
Resistance:	primary	Ω	~ 0,5
	secondary	kΩ	~ 13





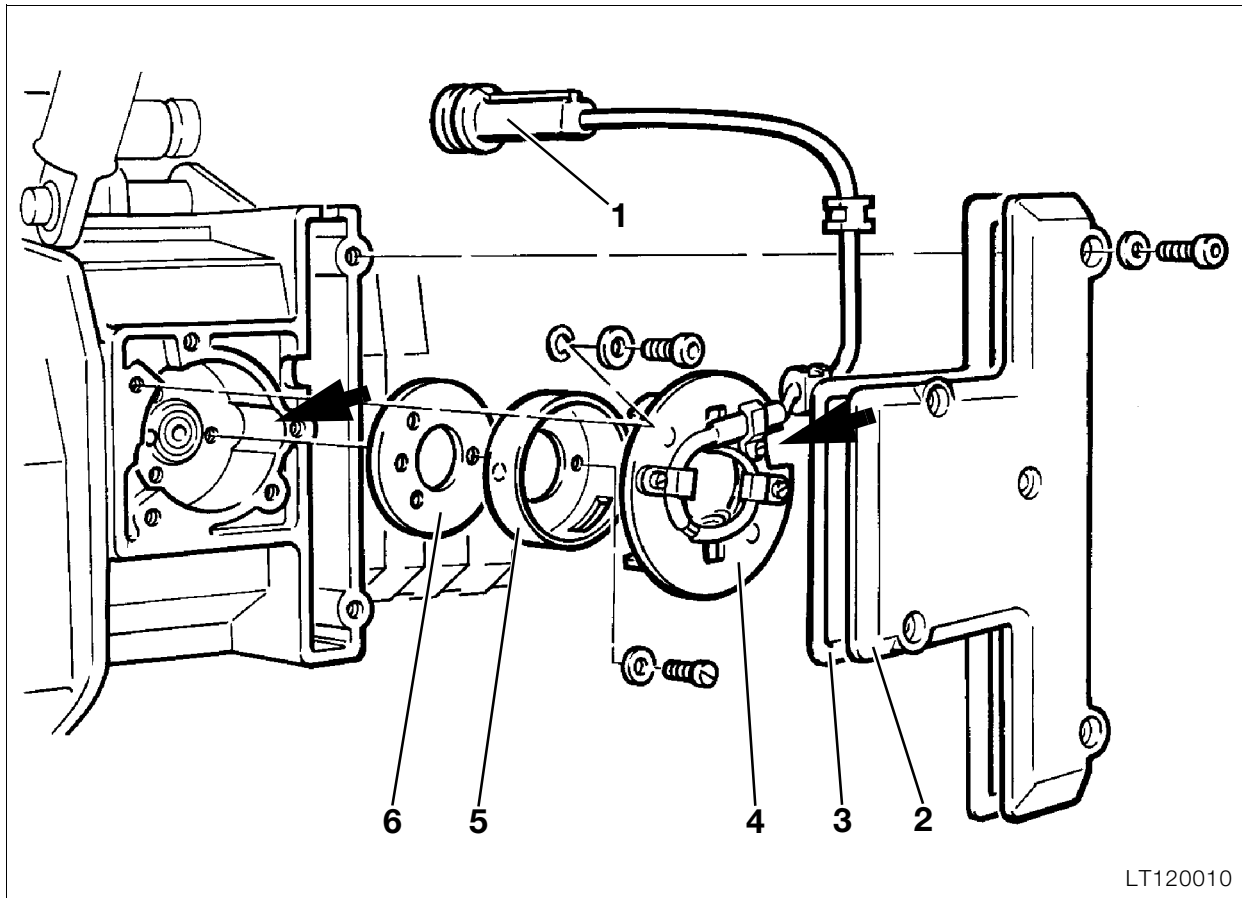

LT120010

Removing and installing Hall generator

- Disconnect ground lead of battery and insulate.
- Remove radiator cowling.
- Remove fuel tank.
- Disconnect Hall generator (1) plug connection.
- Remove cover (2) together with gasket (3).
- Remove base plate (4).
- Remove rotor (5) and setting plate (6).



Note:

Mark installation position of setting plate on engine case, or remove in TDC position.

- Install in the reverse order of removal.



Note:

The recess on the engine case and on the base plate must be aligned flush.



Tightening torques:

Base plate 3.5 Nm
 Cover 9 Nm

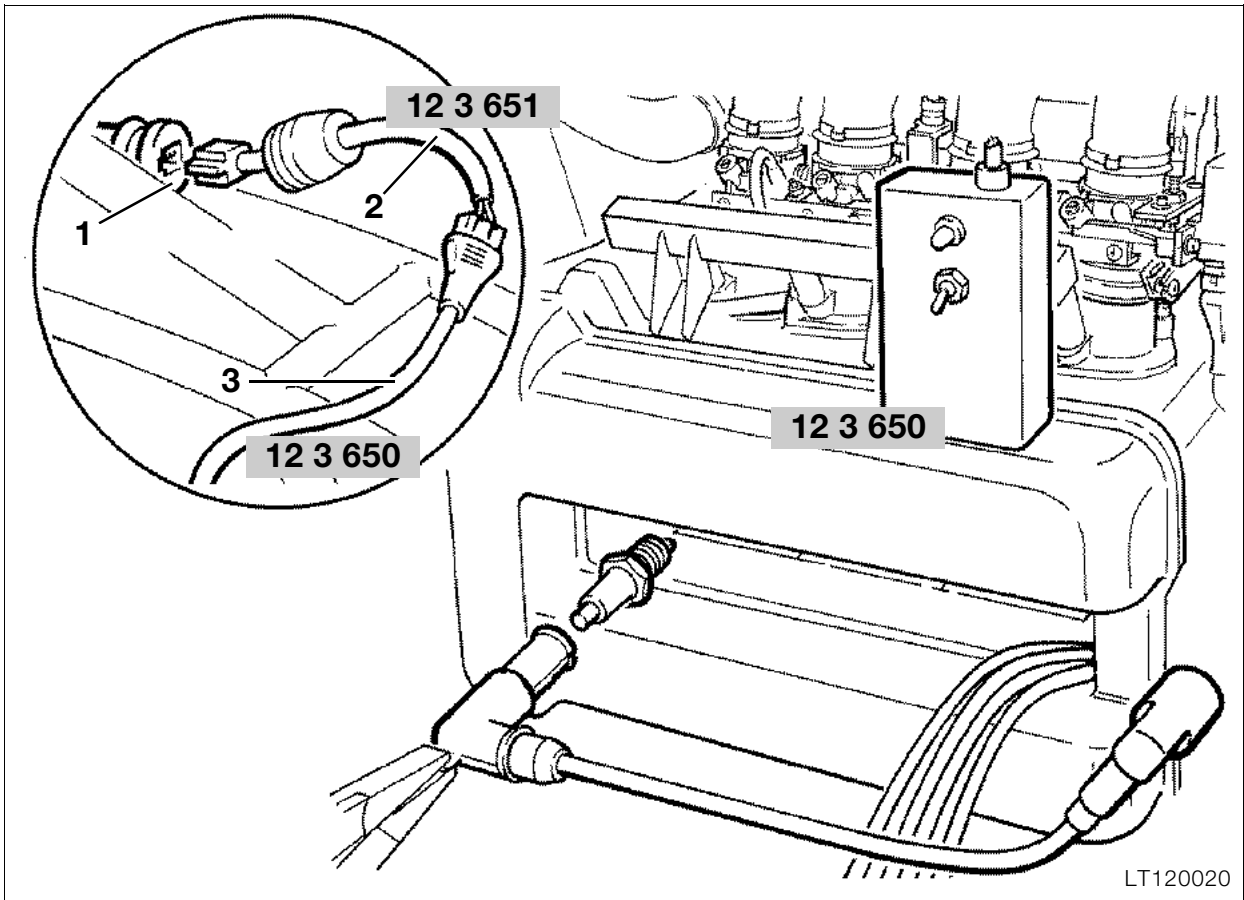

Adjusting ignition timing

- Remove radiator cowling.
- Remove bottom left fairing.
- Remove fuel tank.
- Disconnect plug connection on Hall generator lead under the fuel tank.
- Connect adapter lead (2), **BMW No. 12 3 651**, to Hall generator lead.
- Connect ignition setting device (3), **BMW No. 12 3 650**, to adapter line.
- Disconnect spark plug connector with flat-nose pliers.
- Unscrew spark plugs with spark plug box spanner, **BMW No. 12 3 500**.

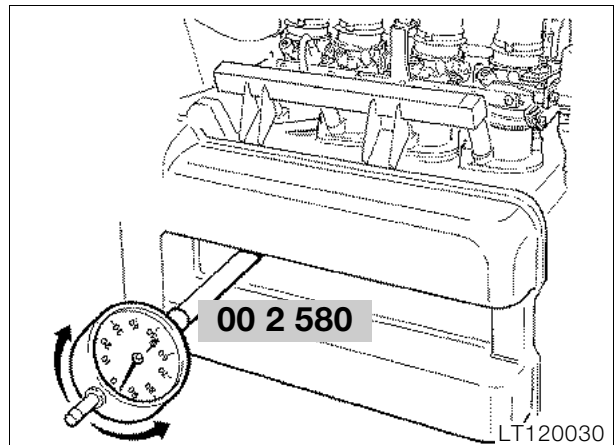

- Screw dial gauge with extension (1), **BMW No. 00 2 580**, into cylinder No. 1.
- Set piston to TDC.
- Set scale ring of dial gauge to 0.
- Turn engine back in clockwise direction until piston setting ignition point is reached.

Ignition point:

6 ° before TDC = 0.24 mm (0.00945 in) before TDC

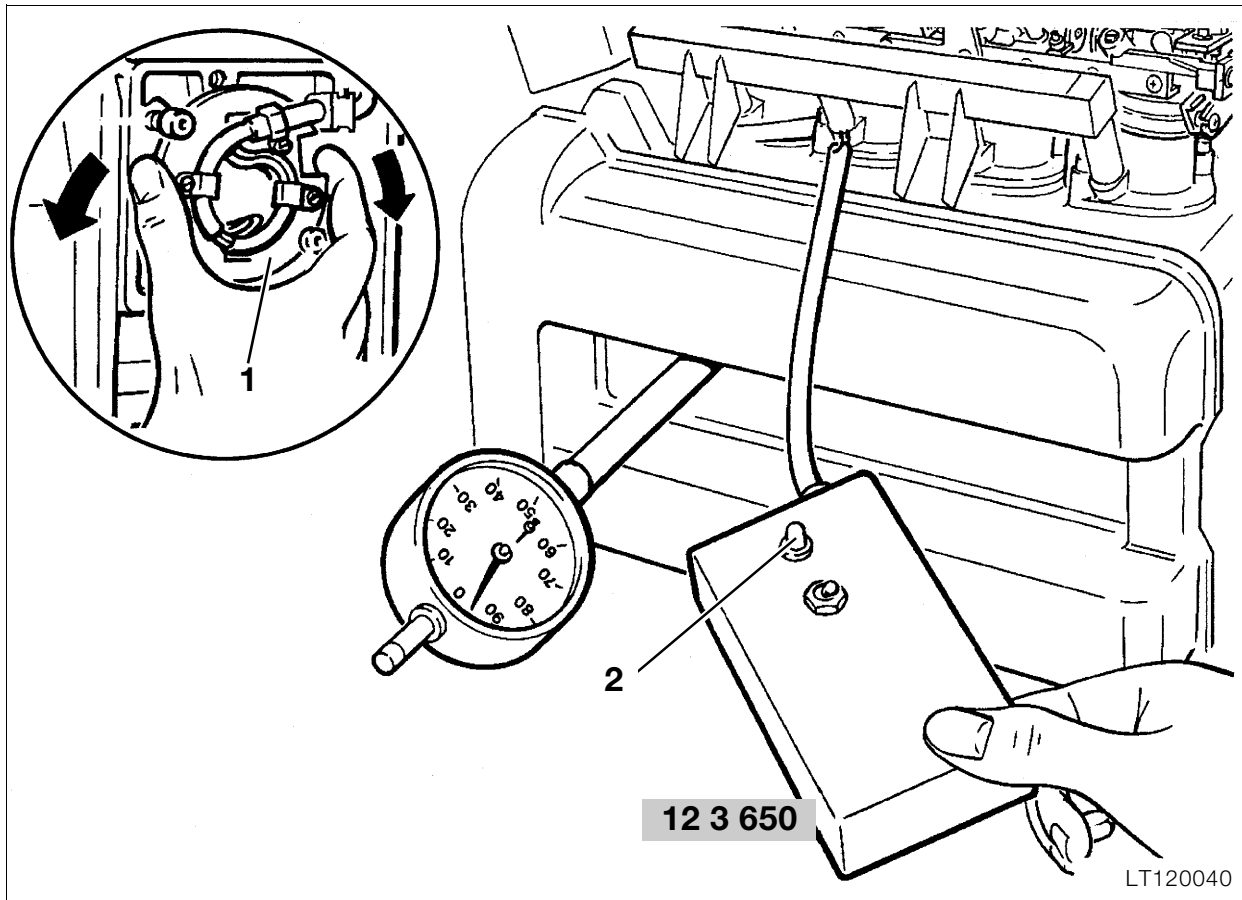

- Loosen base plate (1) and turn to the left or right until diode (2) on ignition setting device goes out.



Note:

Ignition timing adjustment

Turn to left

Turn to right

Retard ignition
Advance ignition

- Firmly tighten base plate.
- Check ignition timing:
Crank engine in normal direction. The diode on the ignition setting device must go out at piston position 0.24 (0.00945 in) mm before TDC.



Tightening torques:

Base plate	3.5 Nm
Cover	9 Nm
Spark plug.....	20 Nm

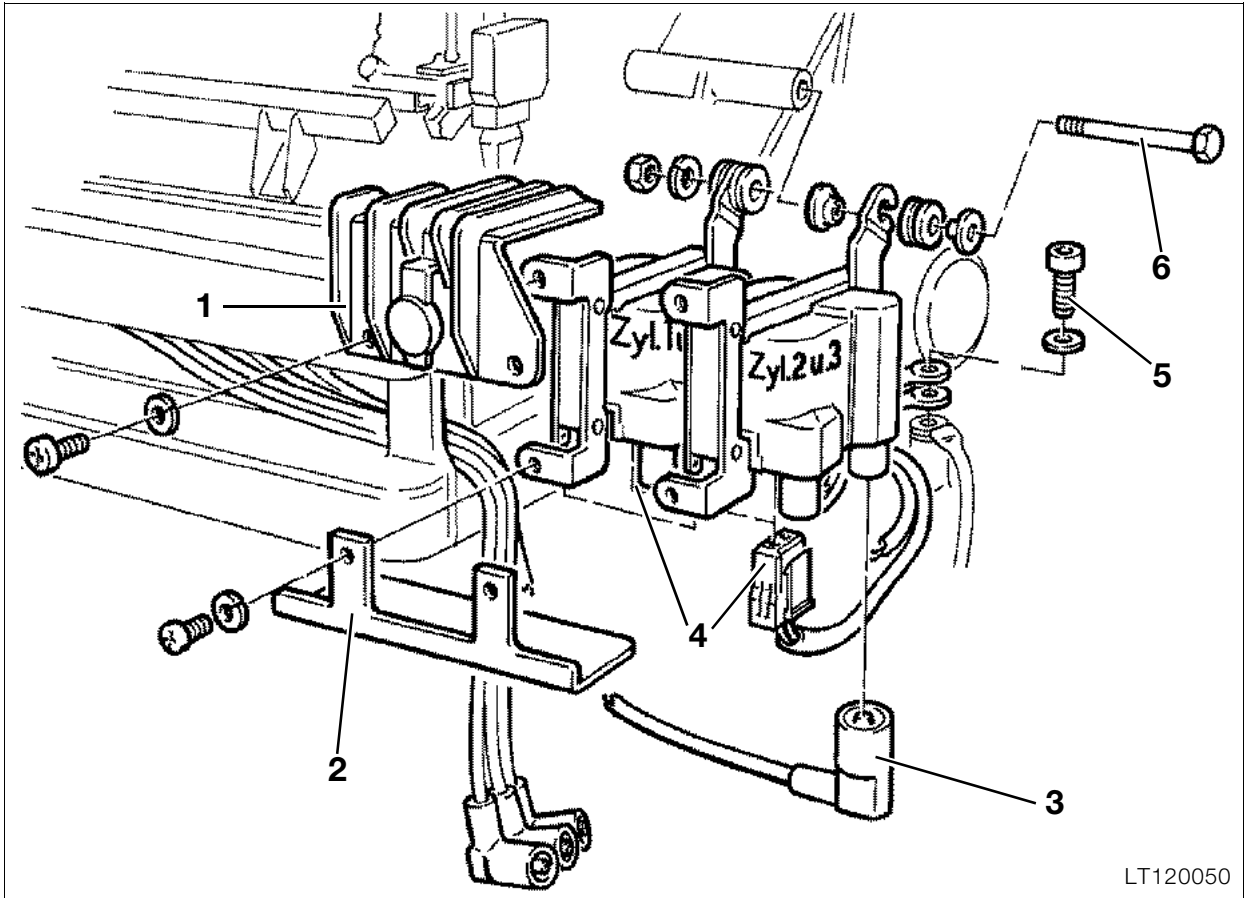

LT120050

Removing and installing ignition coils

- Disconnect earth (ground) lead of battery and insulate.
- Remove top (1) and bottom (2) ignition coil cover.
- Disconnect plug connector (3) at the ignition coils.
- Disconnect plug connector (4) for terminal "1" and "15".
- Release earth (ground) connection (5) on starter.
- Release top and bottom mounting at intermediate flange (6).
- Install in the reverse order of removal.



Note:

Note assignment of ignition leads to ignition coil. Ignition coils are also marked.



Tightening torque:

Ignition coils to intermediate flange 5 Nm

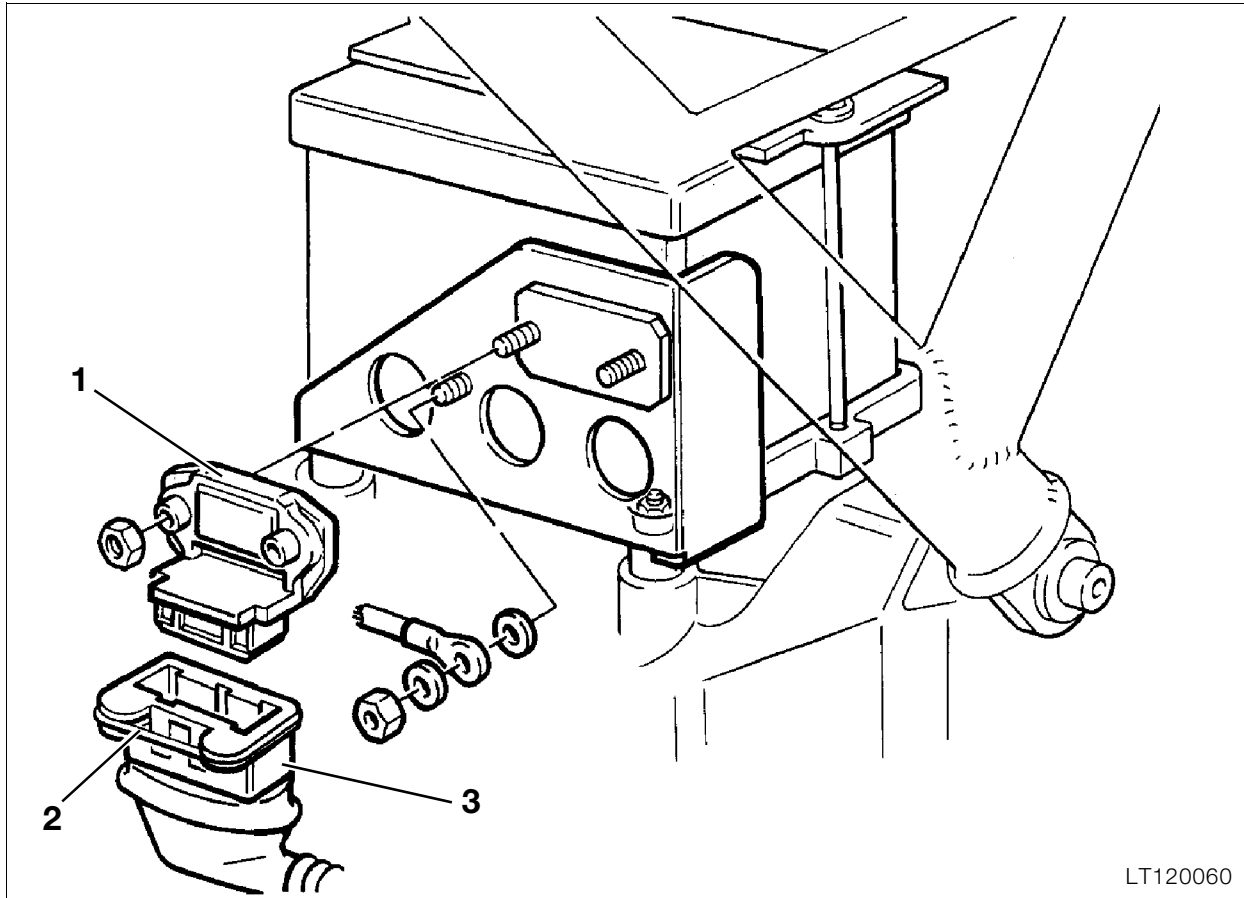

LT120060

Removing and installing ignition output stage

- Remove left battery bracket.
- Disconnect earth (ground) lead of battery.
- Remove ignition coils.
- Remove ignition output stage (1).
- Press retaining clip (2) and detach ignition output stage.
- Install in the reverse order of removal.



Note:

Before installing the ignition output stage, coat the rear with heat conducting paste **Curil K 2**.

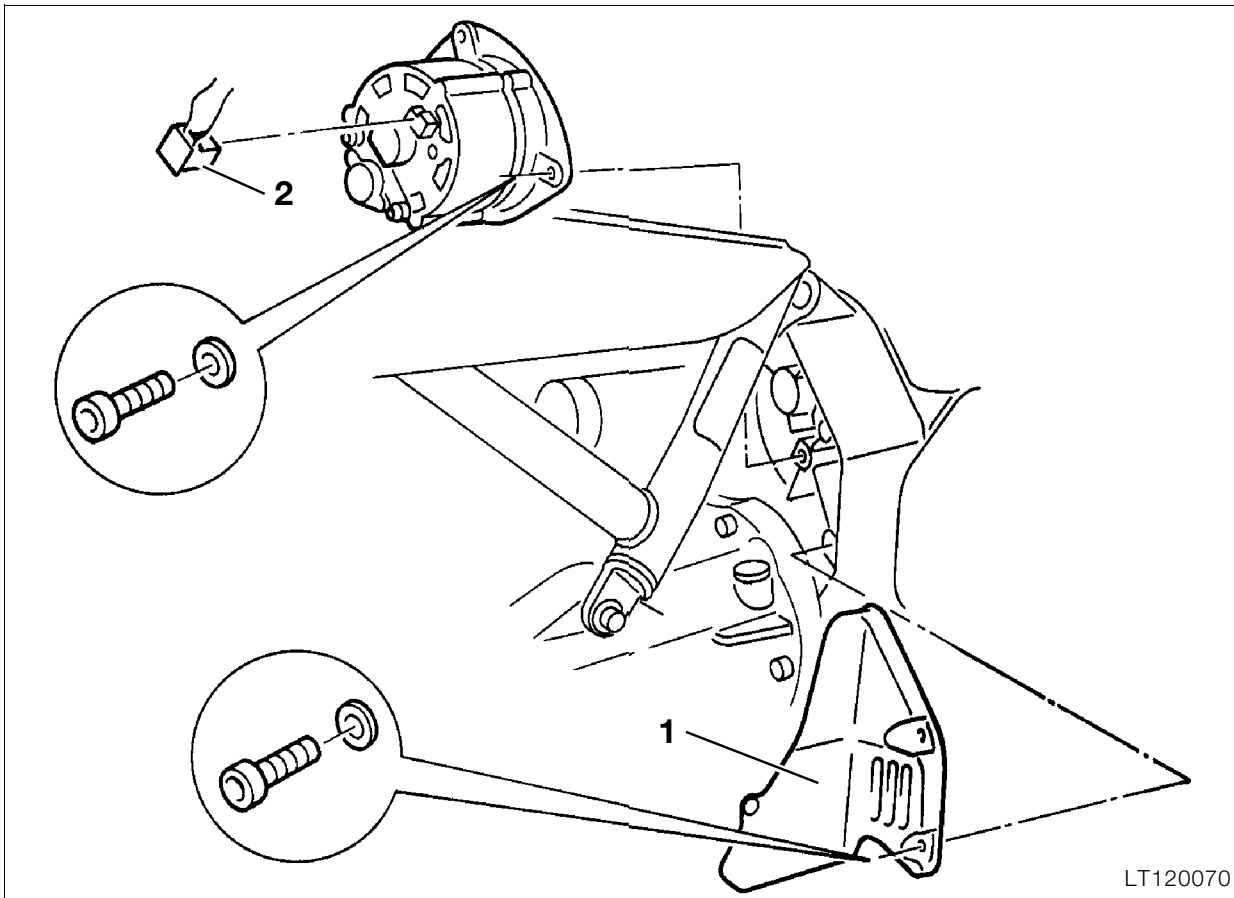

Removing and installing alternator

- Remove right battery panel.
- Remove Motronic control unit.
- **[ABS I]** Remove ABS control unit.
- Remove battery.
- Remove cover (1).
- Disconnect plug (2).
- Remove alternator.
- Install in the reverse order of removal.

 **Tightening torque:**
 Alternator 22 Nm

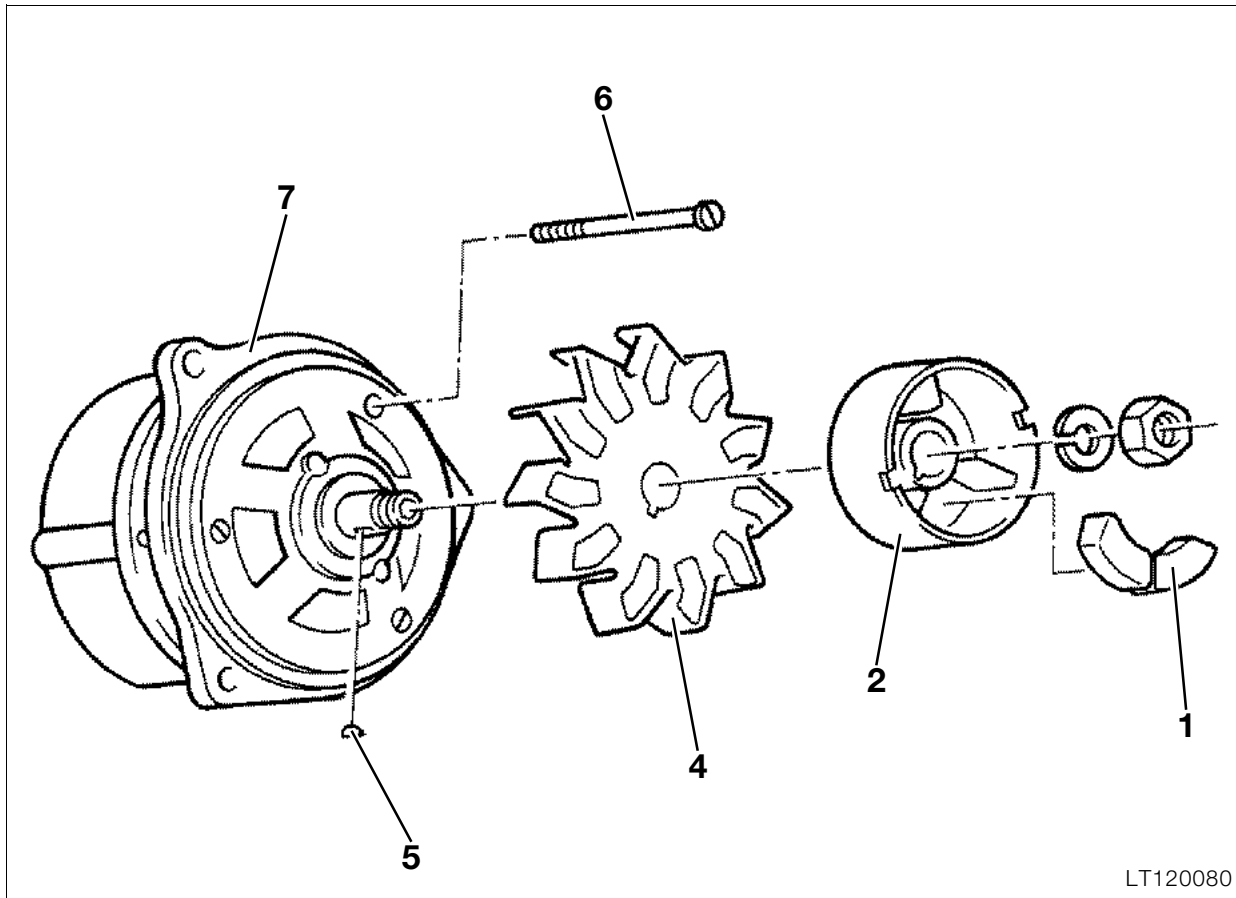

LT120080

Disassembling and assembling alternator

Alternator
[only LT up to 1992 model year]

- Remove damper elements (1)

- Remove coupling housing (2) with holding tool (3), **BMW No. 12 4 600**.
- Pull off fan wheel (4).
- Remove key (5).
- Release retaining screw (6) for bearing end plate.
- Clamp alternator in vice with jaw guards.
- Remove bearing end plate (7) with three-point puller, **BMW No. 33 1 830**.

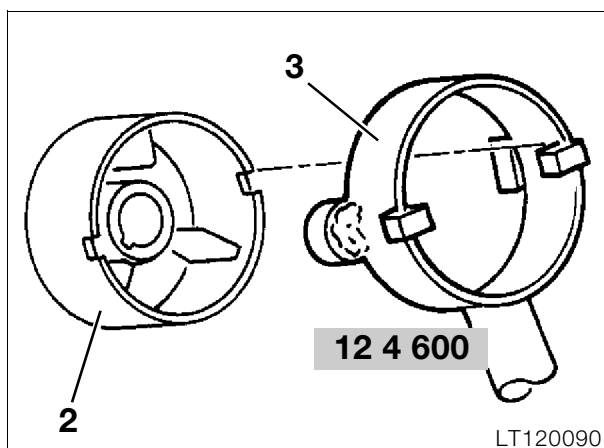

Tightening torque:
Coupling housing.....50 Nm

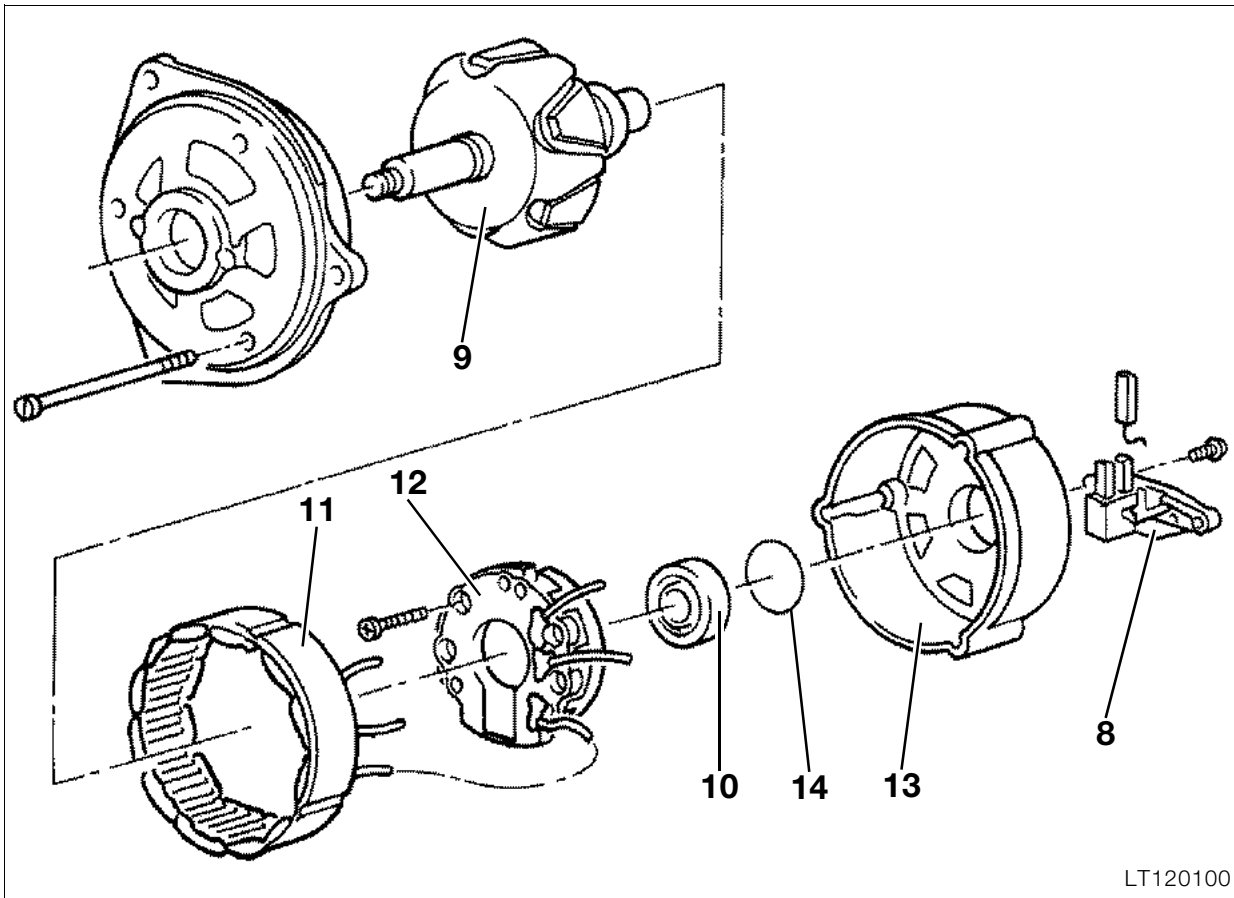

LT120100

- Remove regulator (8) with carbon brushes.
- Carefully lift out armature (9) together with bearing (10).
- Remove bearing (10) from armature shaft.
- Unsolder stator (11) on diode plate (12); mark the wires.
- Remove diode plate.
- Remove O-ring (14).
- Install in the reverse order of removal.



Note:

During assembly, insulate the solder points on the diode plate with silicone. Coat bearing seat in housing with Molykote paste.

Checking exciter winding

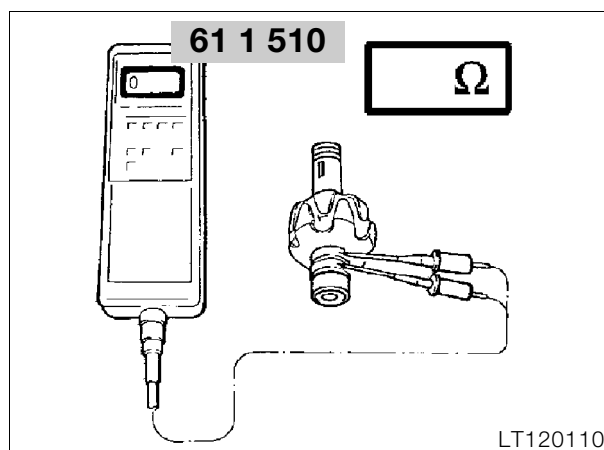

LT120110

- Using the test probes of the BMW diagnosis tester, **BMW No. 61 1 510**, measure the resistance across the slip rings.

Nominal resistance..... $7 \pm 1 \Omega$

Checking armature for short to earth

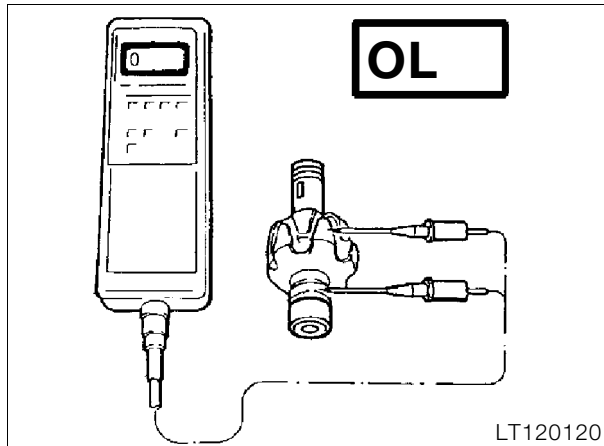

LT120120

- Measure resistance between slip rings and armature.



Note:

The resistance must be infinitely large.

Measurement result: OL = open line

Checking resistance between phase outputs

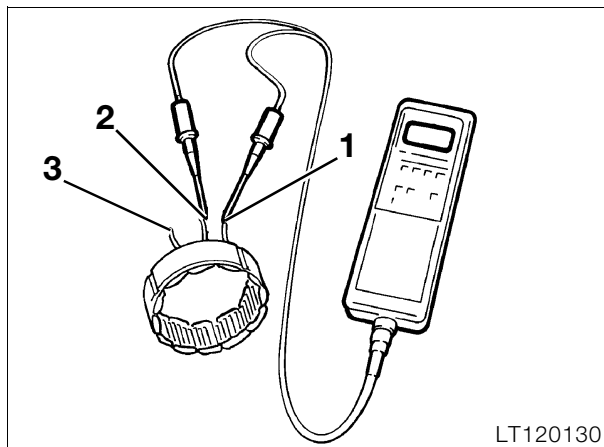

LT120130

- Check resistance between each pair of outputs.
1 – 2
1 – 3
2 – 3

Nominal resistance: 0,6 Ω

The winding is in perfect working order at measured values below 1.0 Ω.

Checking stator winding for short to earth

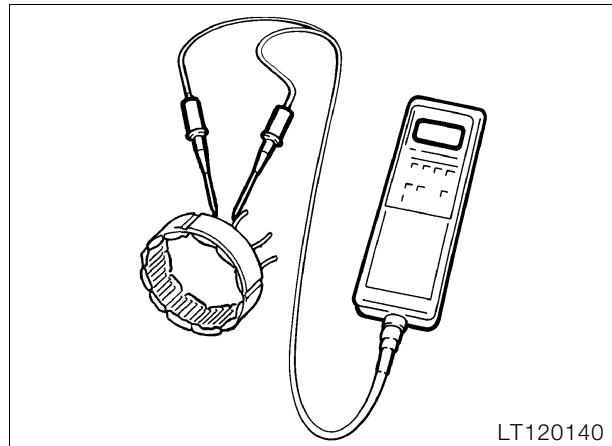

LT120140

- Check winding outputs individually with respect to earth.



Note:

The resistance must be infinitely large.
Measurement result: OL = open line.

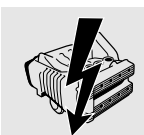

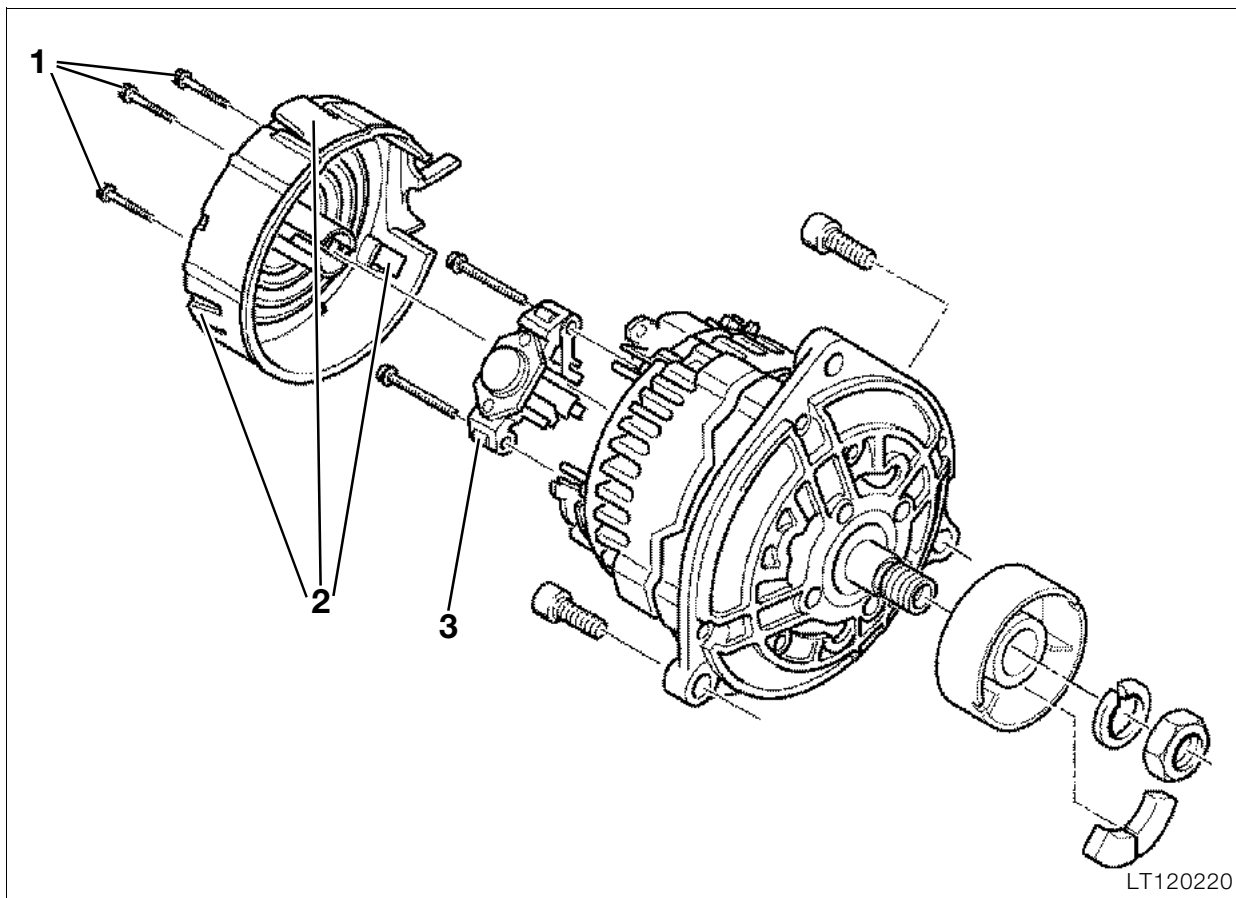

Alternator [LT from 1992 model year on, RS]

- Remove fastening screws (1) from cover.
- Release clips (2) and take off cover.
- Remove voltage regulator (3)

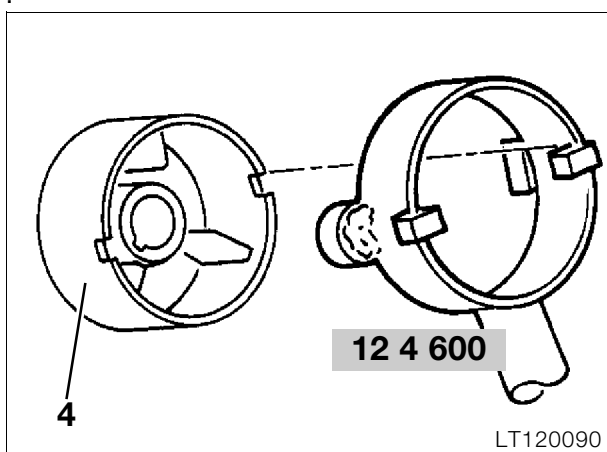

- Remove coupling housing (4), using counter-holder, **BMW No. 12 4 600**.
- Assemble in the reverse order of work.

 **Tightening torque:**
Coupling housing 50 Nm

Checking alternator



Note:

Before measuring the resistance with the BMW diagnostic tester, this must be zeroed:
Connect the positive (yellow) and negative (green) leads.
Press the Ω key until the digital display shows 0.00 Ω .

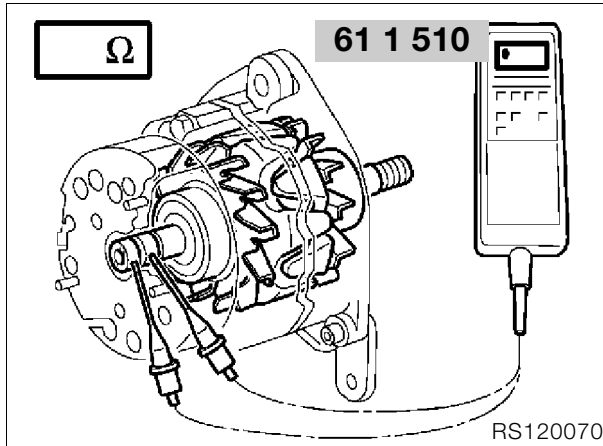

- Using BMW diagnostic tester, **BMW No. 61 1 510**, measure the resistance between the sliprings.

Measured result:3 Ω

Checking armature for short to earth

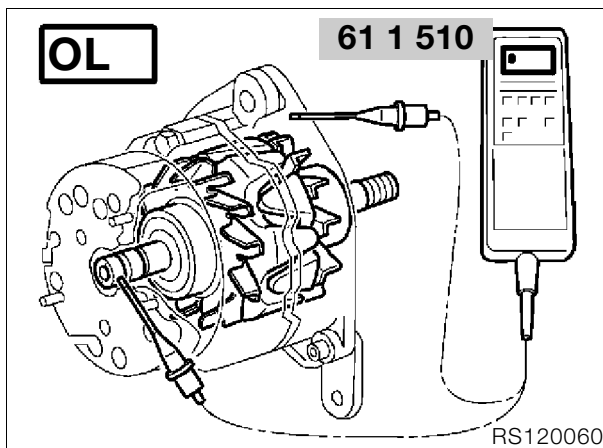

- Measure resistance between sliprings and armature.

Measured result: OL = open line



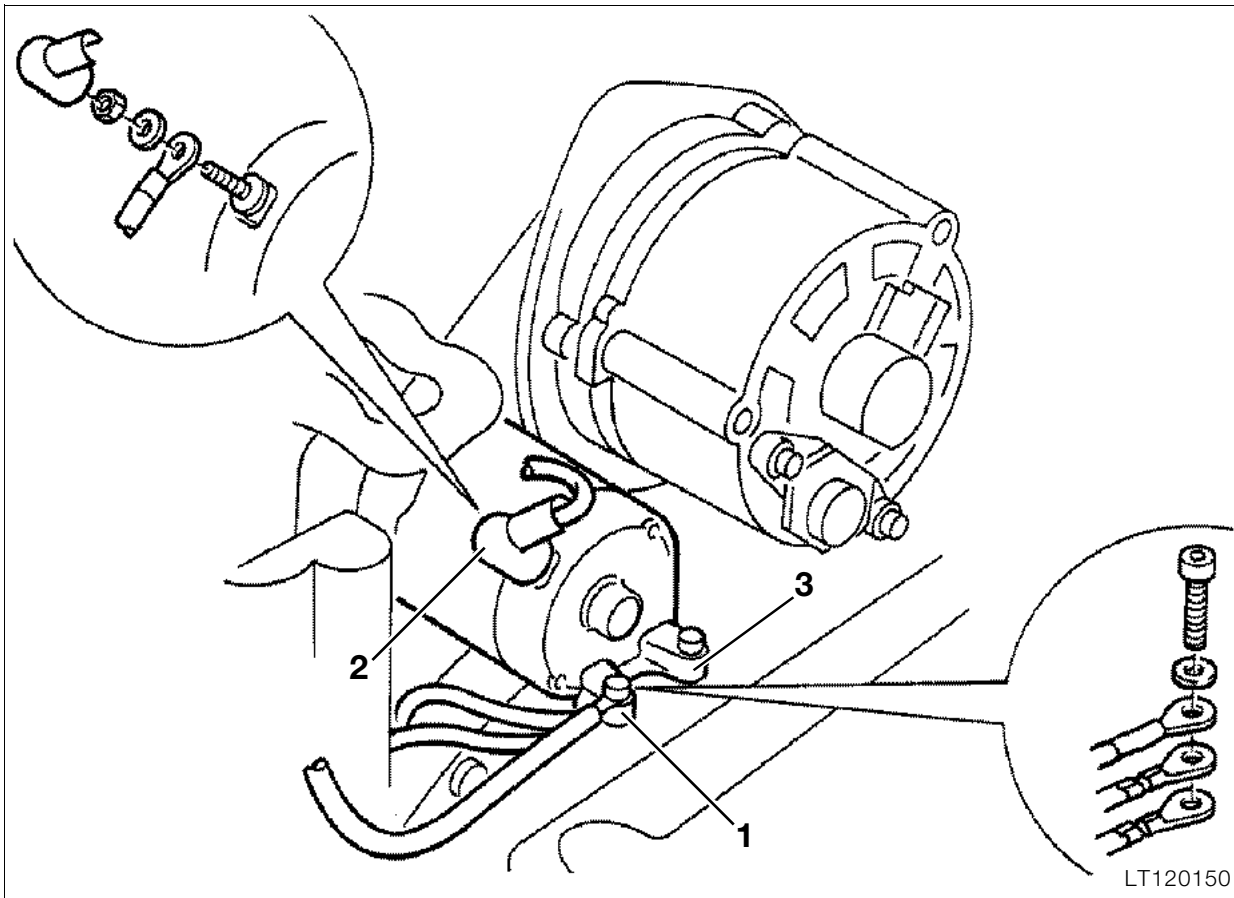

Removing and installing starter

- Remove control unit.
- **[ABS I]** Remove control unit.
- **[ABS II]** Drain front and rear brake systems.
- **[ABS II]** Remove pressure modulator.
- Remove battery.
- **[ABS II]** Take off battery carrier.
- Release earth (ground) connection (1) at starter.
- Release positive lead at starter.
- Release second retaining screw (3).
- Pull out starter towards rear.
- Install in the reverse order of removal.



Note:

[ABS II] Refill the front and rear brake systems.



Tightening torques:

Starter to transmission 9 Nm
 Positive lead to starter..... 5 Nm

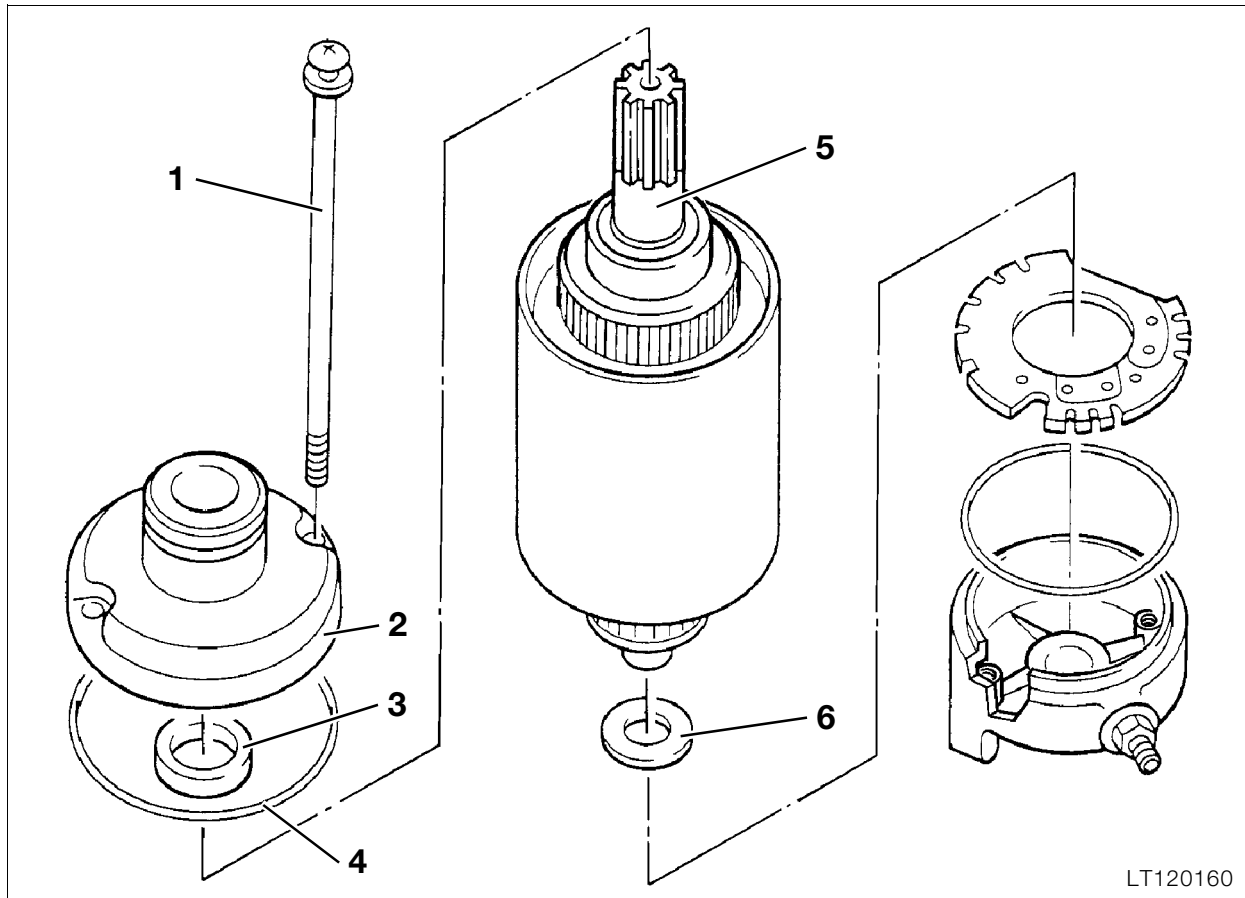

LT120160

Disassembling and assembling starter

- Clamp starter at retaining lugs in vice with jaw guards.
- Release retaining bolts (1).
- Detach bearing cap (2).
- Check seal (3) and O-ring (4).
- Pull out armature (5).
- Note spacer washer (6)
- Check O-ring (10).

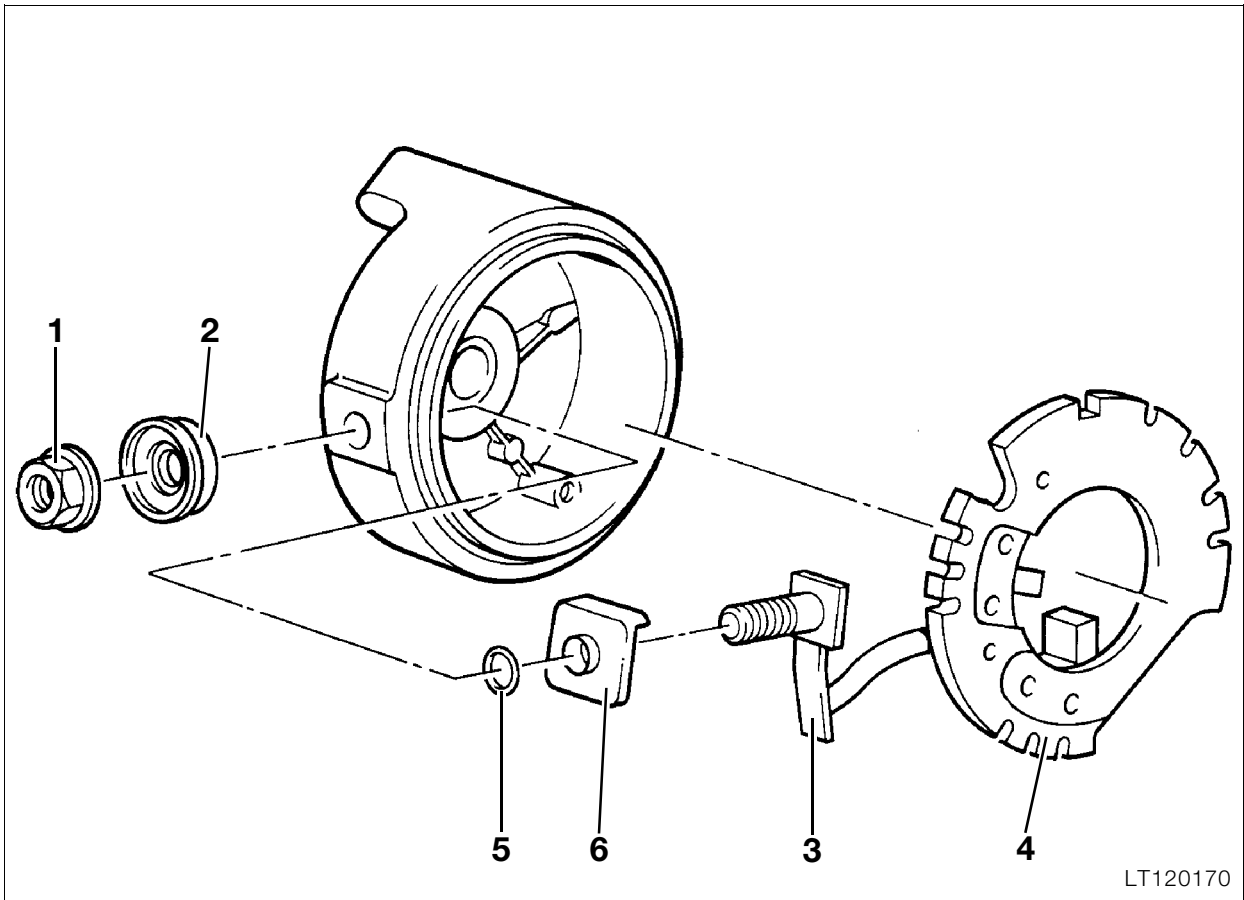

Removing and installing brush holder

1. Hexagon nut
2. Outer insulator
3. Carbon brush holder
4. Brush retaining plate
5. O-ring
6. Inner insulator

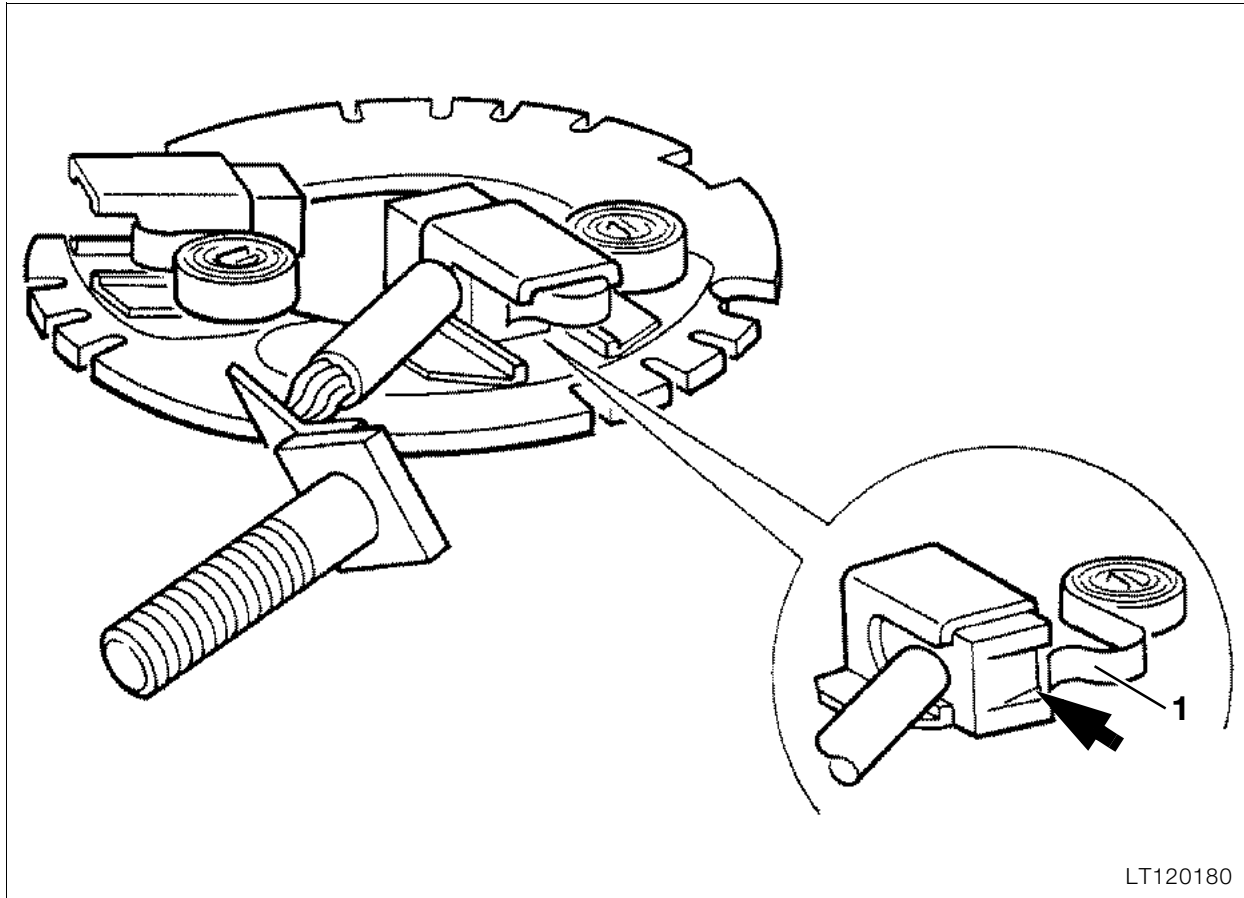

LT120180

Renewing carbon brushes

- With the aid of a small screwdriver, lift spring (1) and pull out carbon brush.



Note:

Fit carbon brush so that the chamfered side (arrow) faces towards the spring.



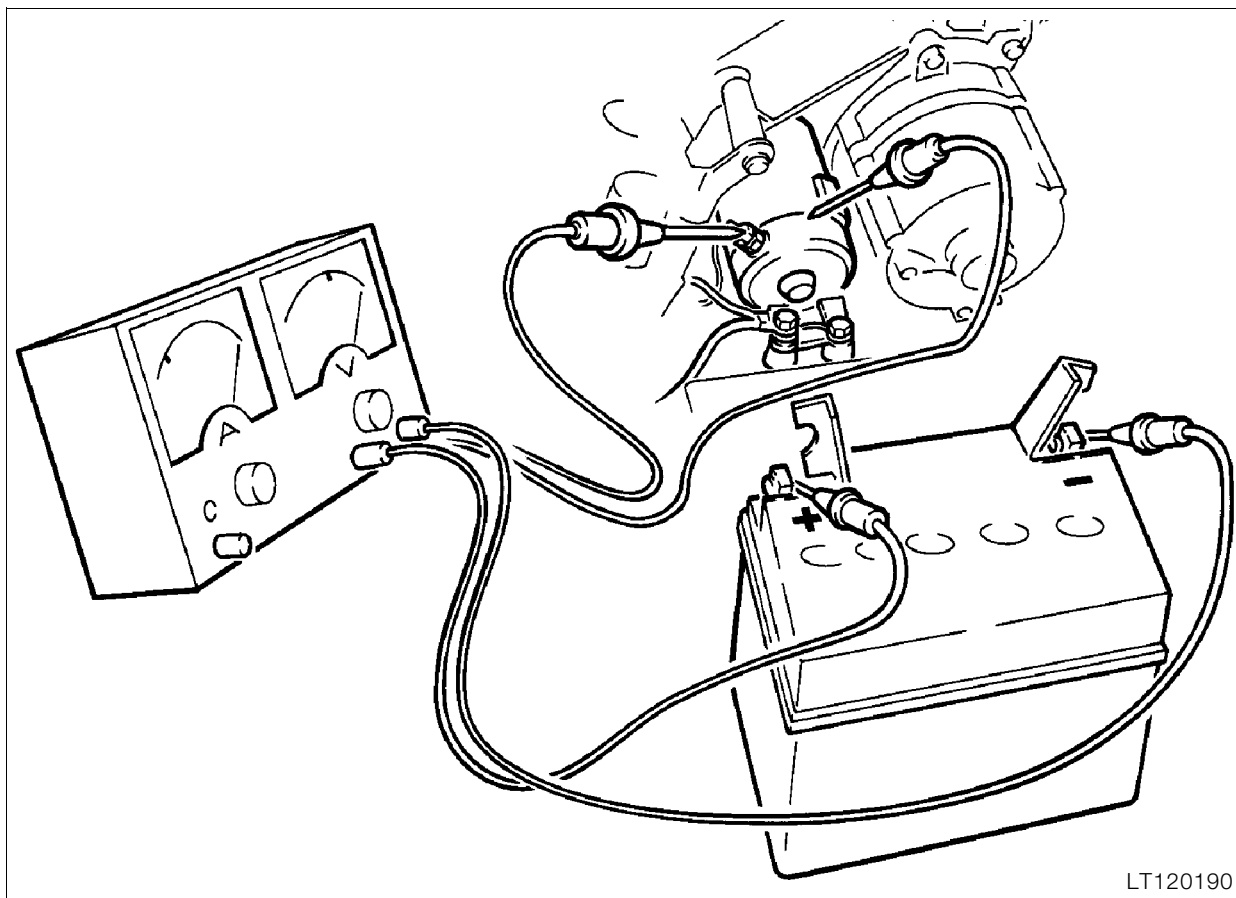

Checking starter

- Connect voltmeter between positive and negative pole of battery.
- Operate starter for 2...3 seconds.
- Read off value.



Note:

If the read-off value is below 8 Volt, this indicates the battery does not have its full capacity.
Note down value if measured value is above 8 Volt.

- Connect voltmeter between positive and negative lead at starter.
- Operate starter for 2...3 seconds.
- Read off measured value and compare with the value noted down.



Note:

The starter is defective if the difference between the two values is greater than 0.5 Volt.

Checking starter relay

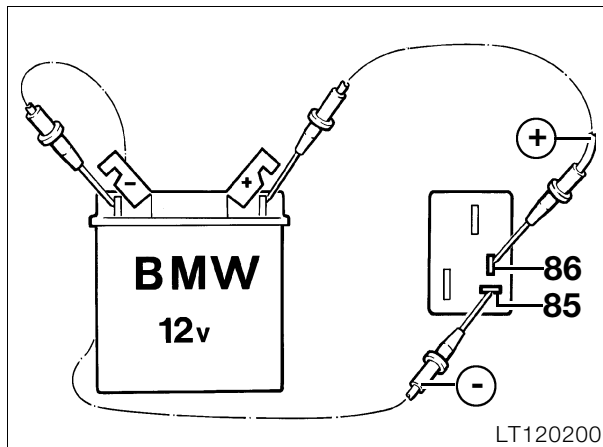

- Connect terminal 86 to positive battery terminal, terminal 85 to earth (ground).



Note:

The relay is defective if no switching noise can be heard.
Check resistance if clear switching noise can be heard.

Checking starter relay with ohmmeter

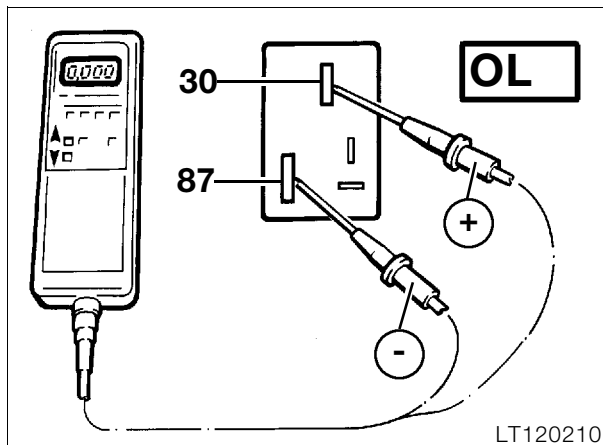

- Connect positive lead from measuring instrument to terminal 30, negative lead to terminal 87.



Note:

Ω value indicated means relay is defective.



Troubleshooting

Troubleshooting on alternator

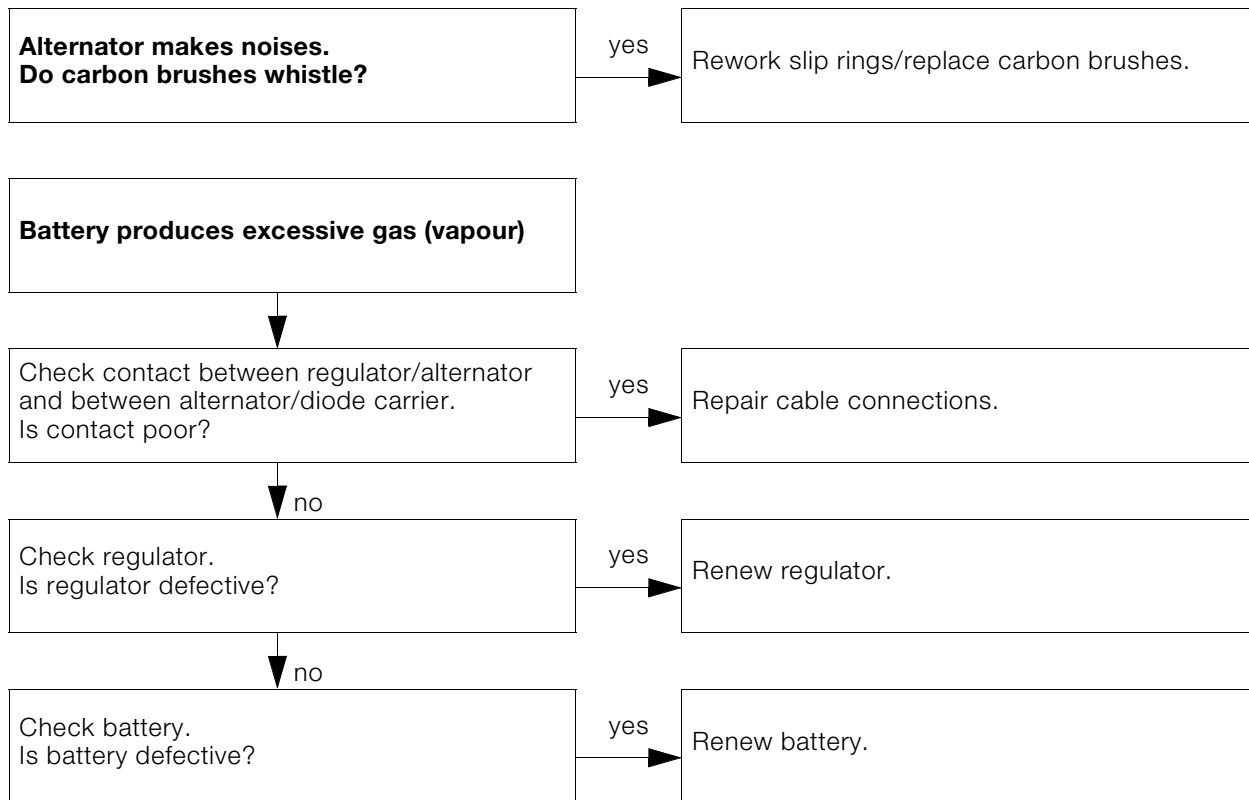

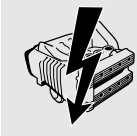
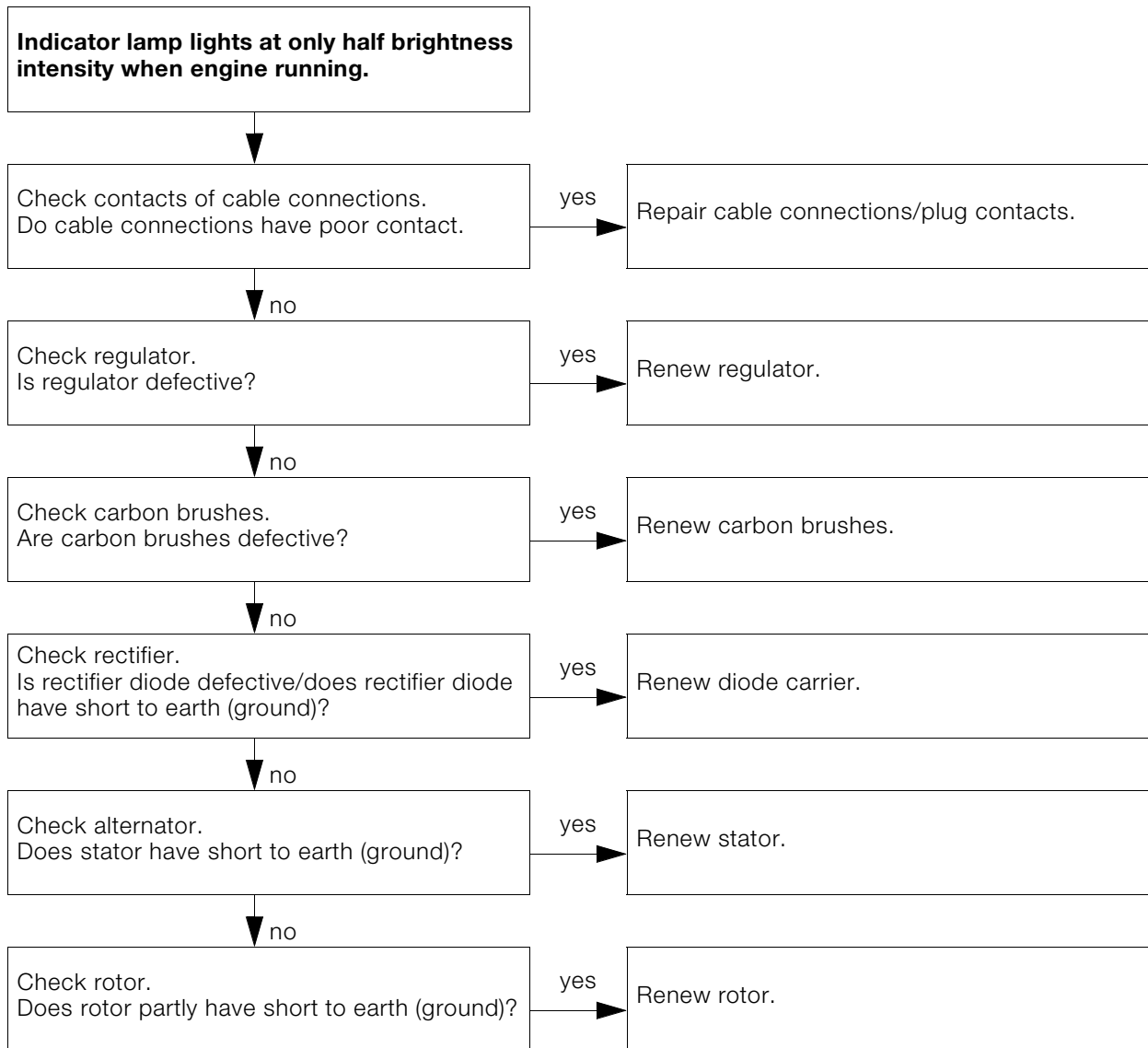

Indicator lamp lights at half or full brightness with engine running.

Check regulator.
Is regulator defective?

yes

Renew regulator.

no

Check supply line.
Does supply line have break/short circuit?

yes

Repair break;
renew cable/connection elements.

no

Check carbon brushes.
Are carbon brushes defective?

yes

Renew carbon brushes.

no

Check rotor winding.
Is rotor winding defective?

yes

Replace rotor.

no

Check exciter current circuit.
Is exciter current circuit broken?

yes

Repair break;
renew cable/connection elements.

no

Check diode/diode carrier.
Is diode/diode carrier defective?

yes

Replace diode/diode carrier.

no

Check cable D +/61.
Has cable short to ground?

yes

Repair short-circuit;
if necessary renew cable.



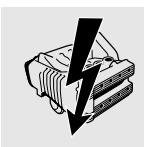
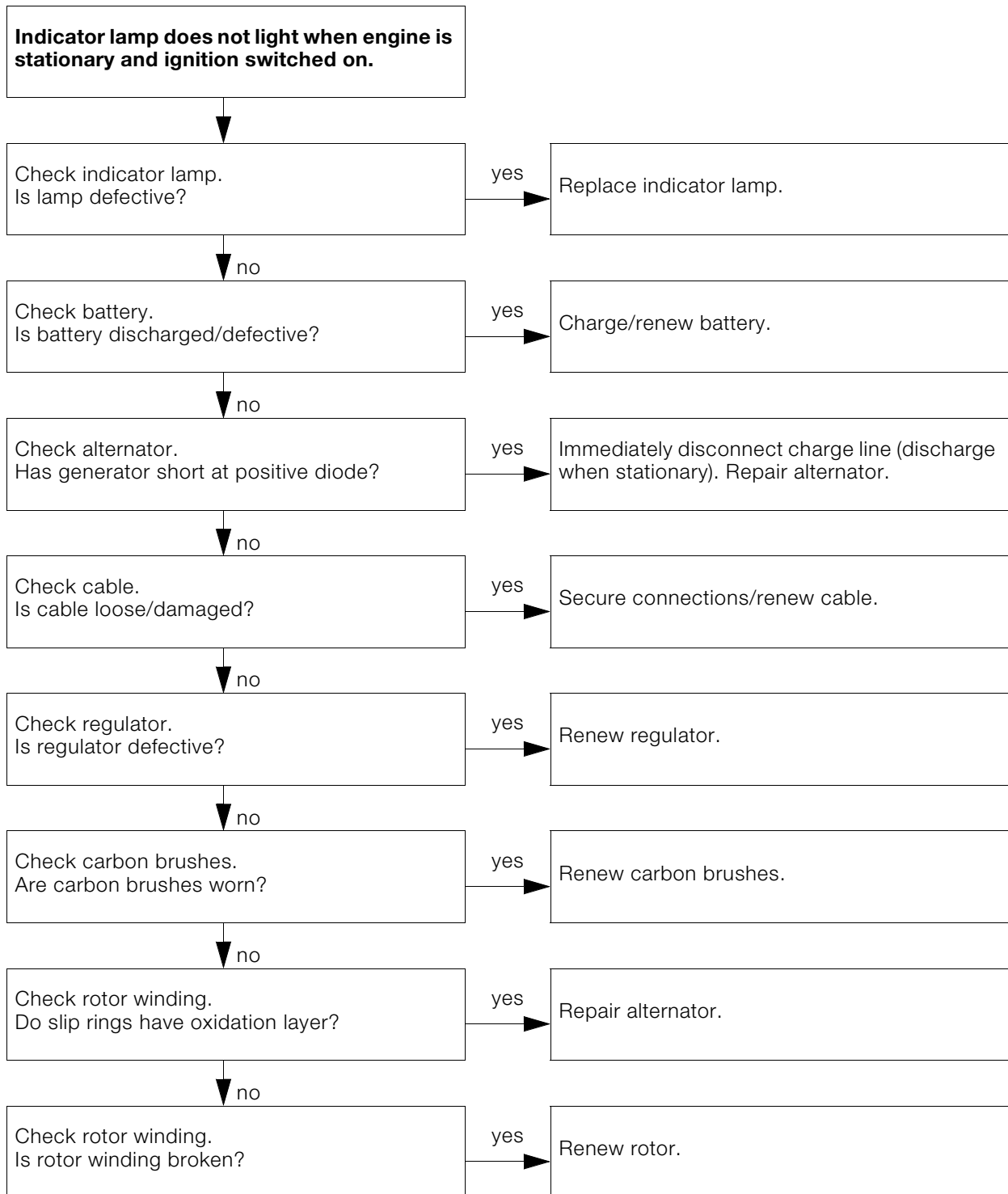

Troubleshooting on starter

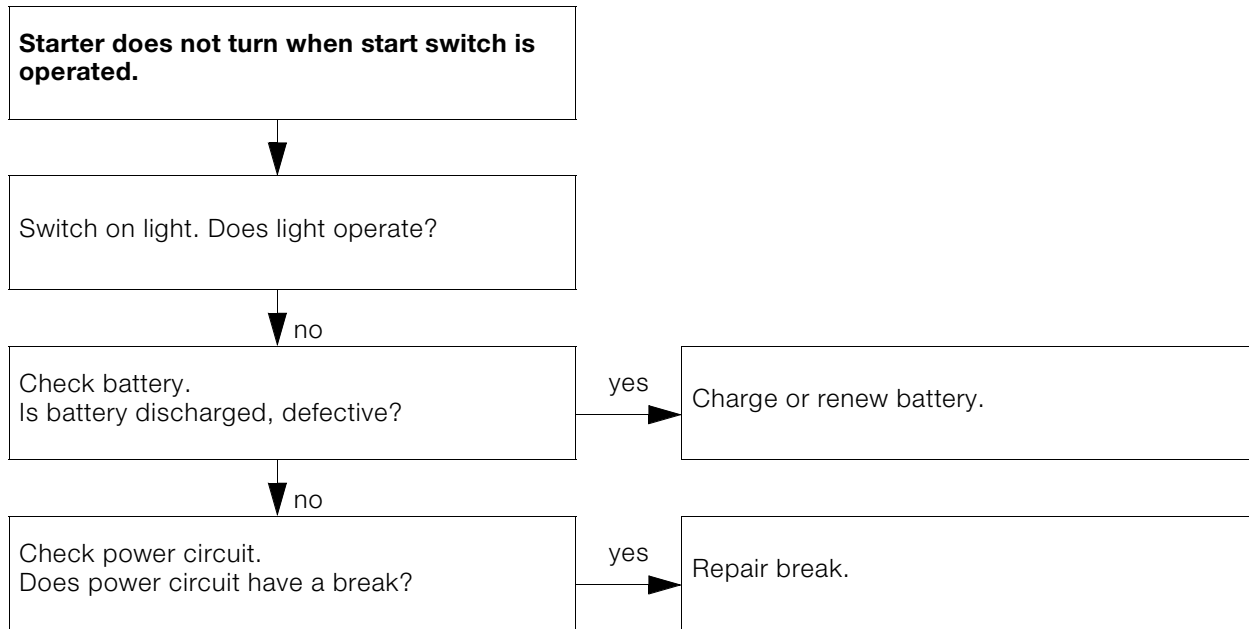

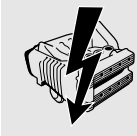
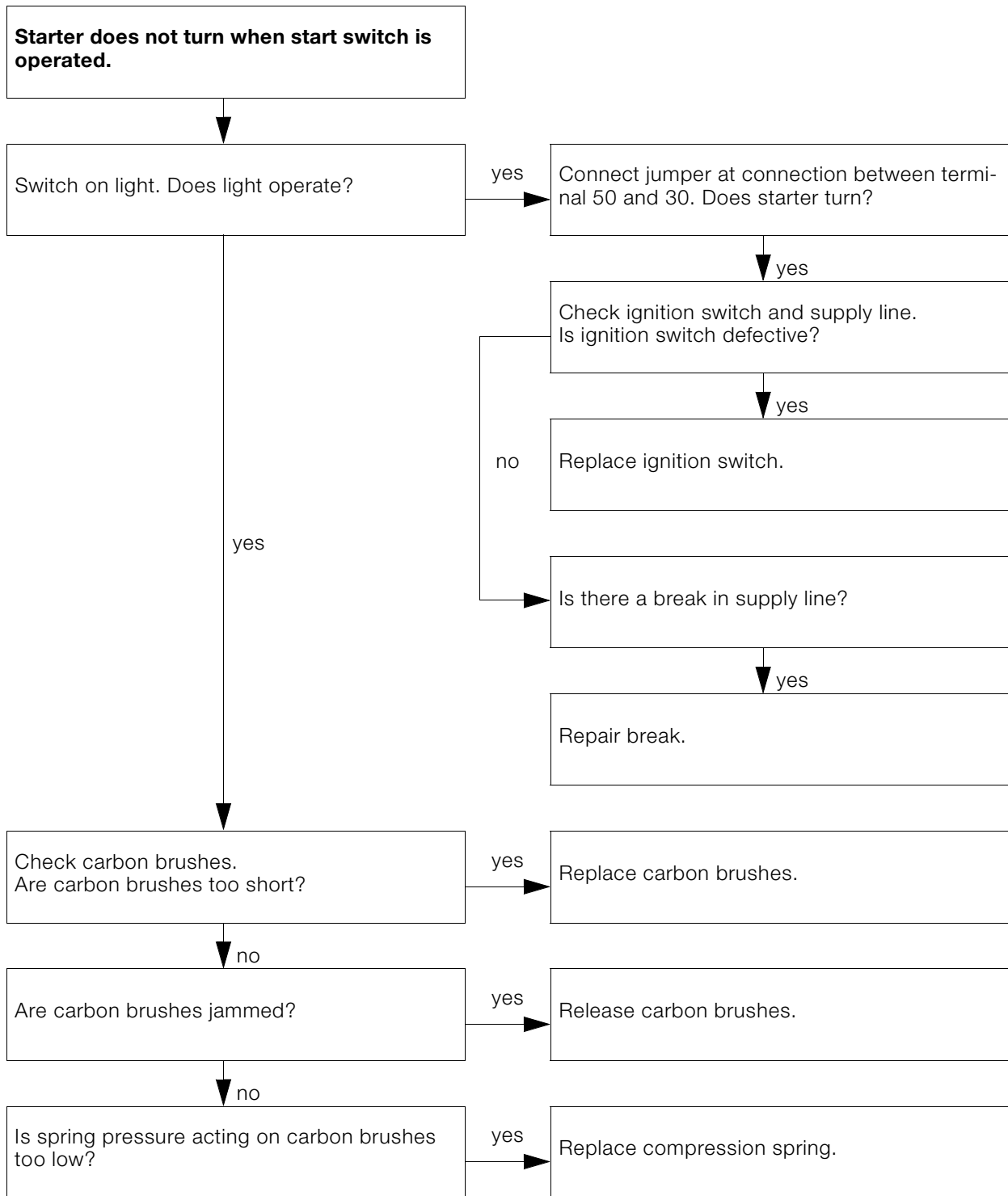



Starter turns too slowly, does not crank engine.

Check battery voltage.
Is battery voltage too low?

yes

Charge battery, replace if necessary.

no

Check battery terminals.
Are terminals loose or oxidised?

yes

Clean poles and terminals, firmly tighten.

no

Check connections.
Are connections loose?

yes

Secure connections.

no

Check collector.
Is collector dirty?

yes

Clean collector.

no

Check armature winding.
Is armature winding defective?

yes

Repair starter.

**Starter turns at high speed.
Engine stops or turns only sporadically.**

Check drive pinion. Is drive pinion defective?
Is shift lever broken?

yes

Repair starter.

**Drive pinion does not engage.
Starter turns idle at high speed.**

Check drive pinion.
Is drive pinion excessively dirty?

yes

Repair starter.

Troubleshooting on battery

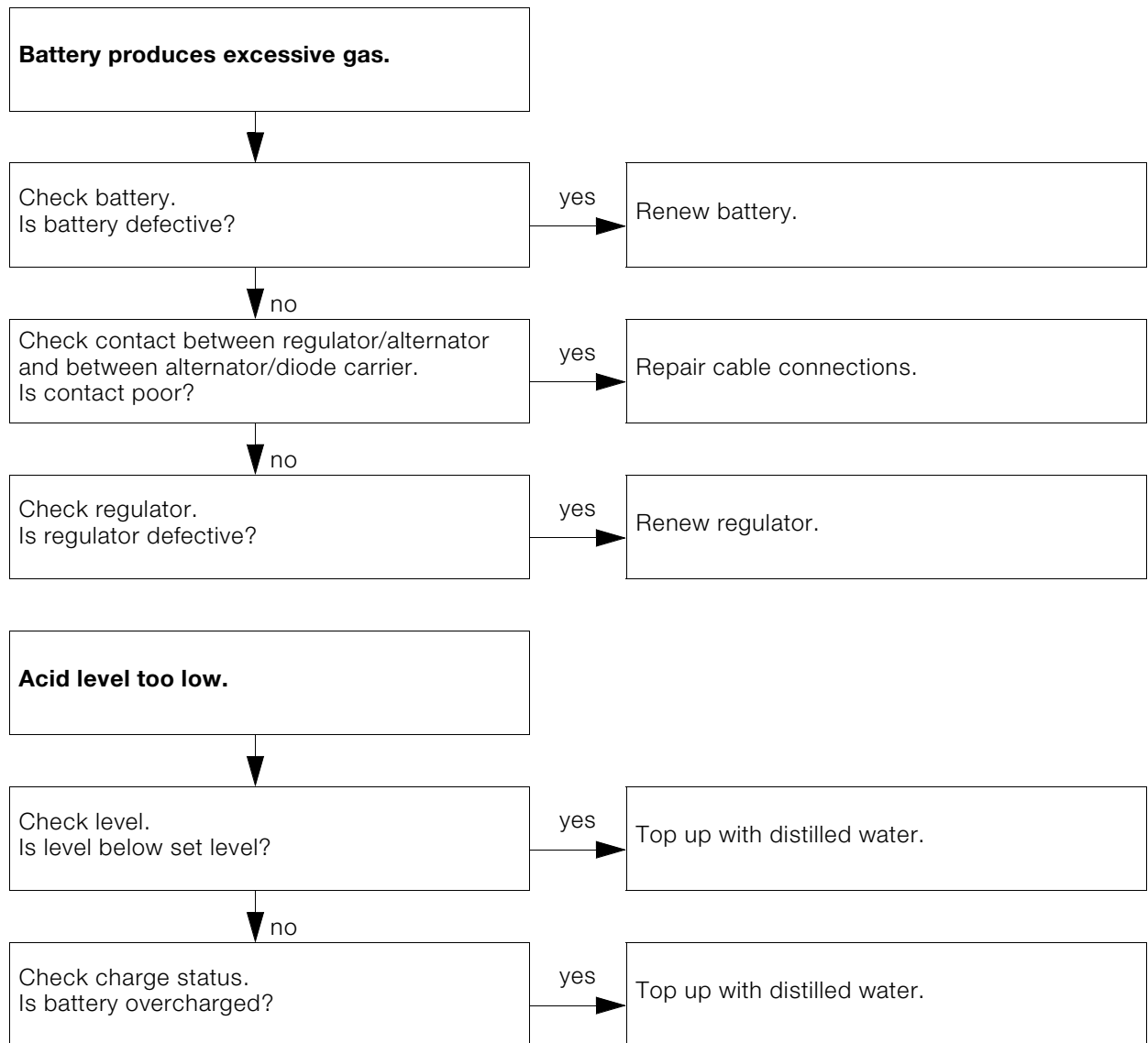

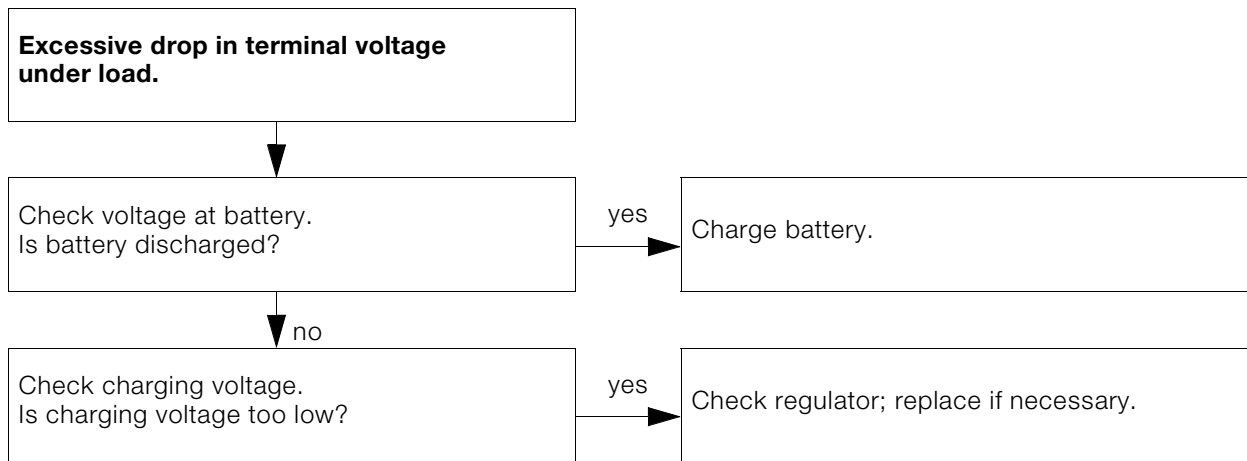
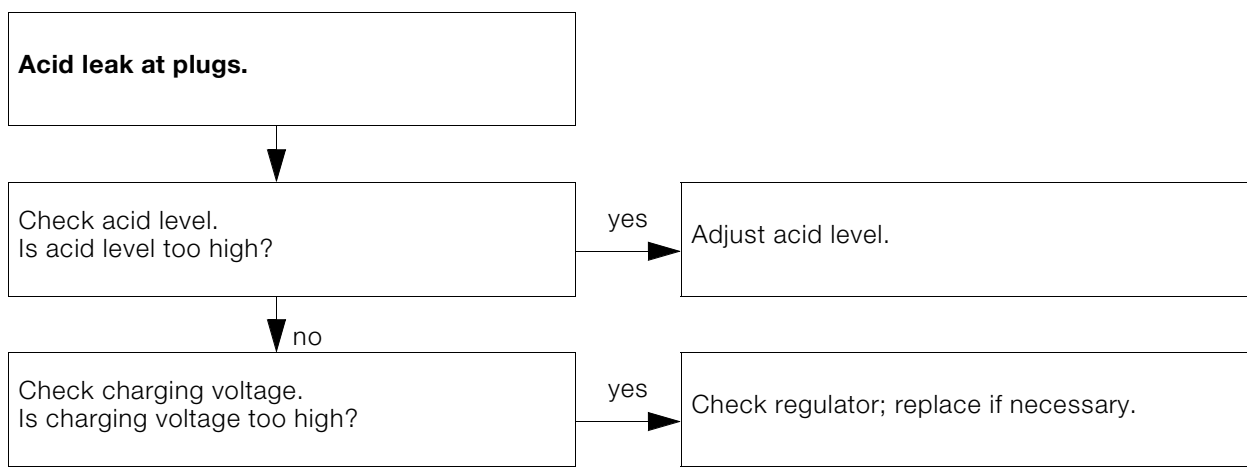
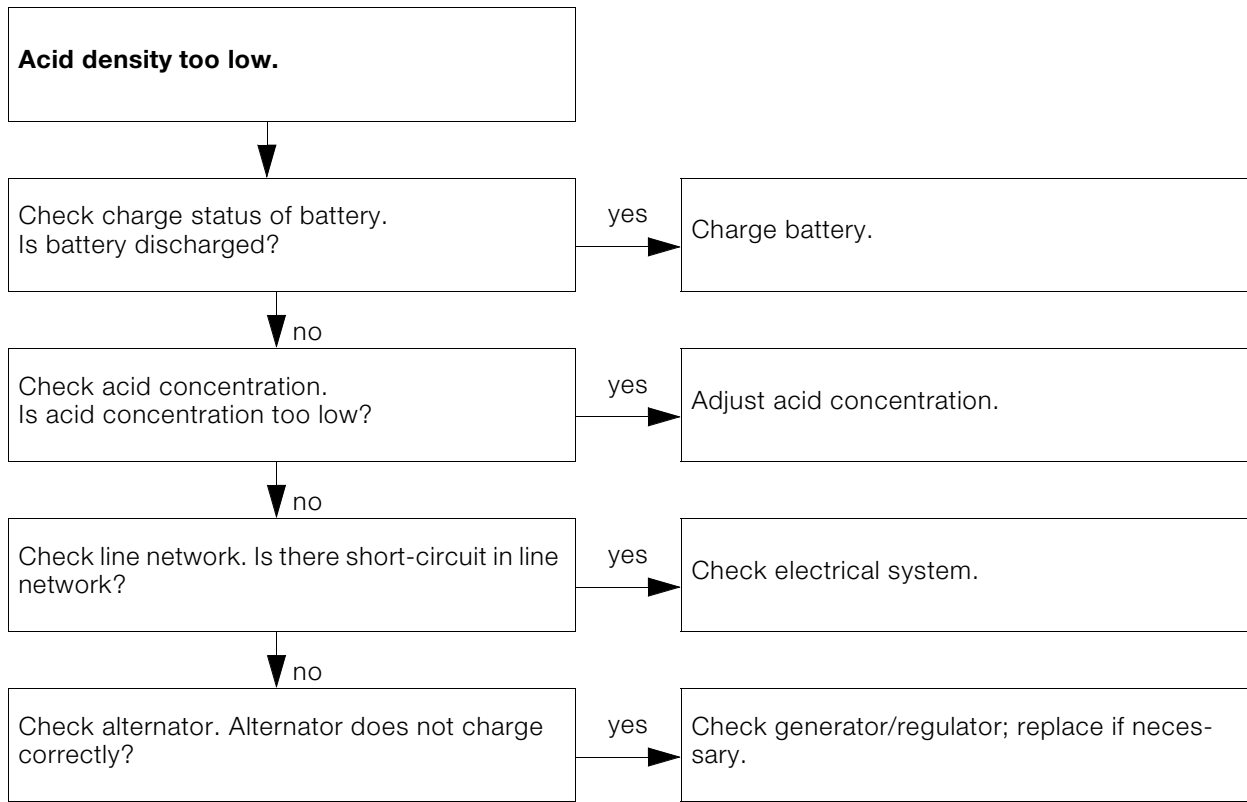

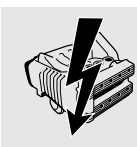
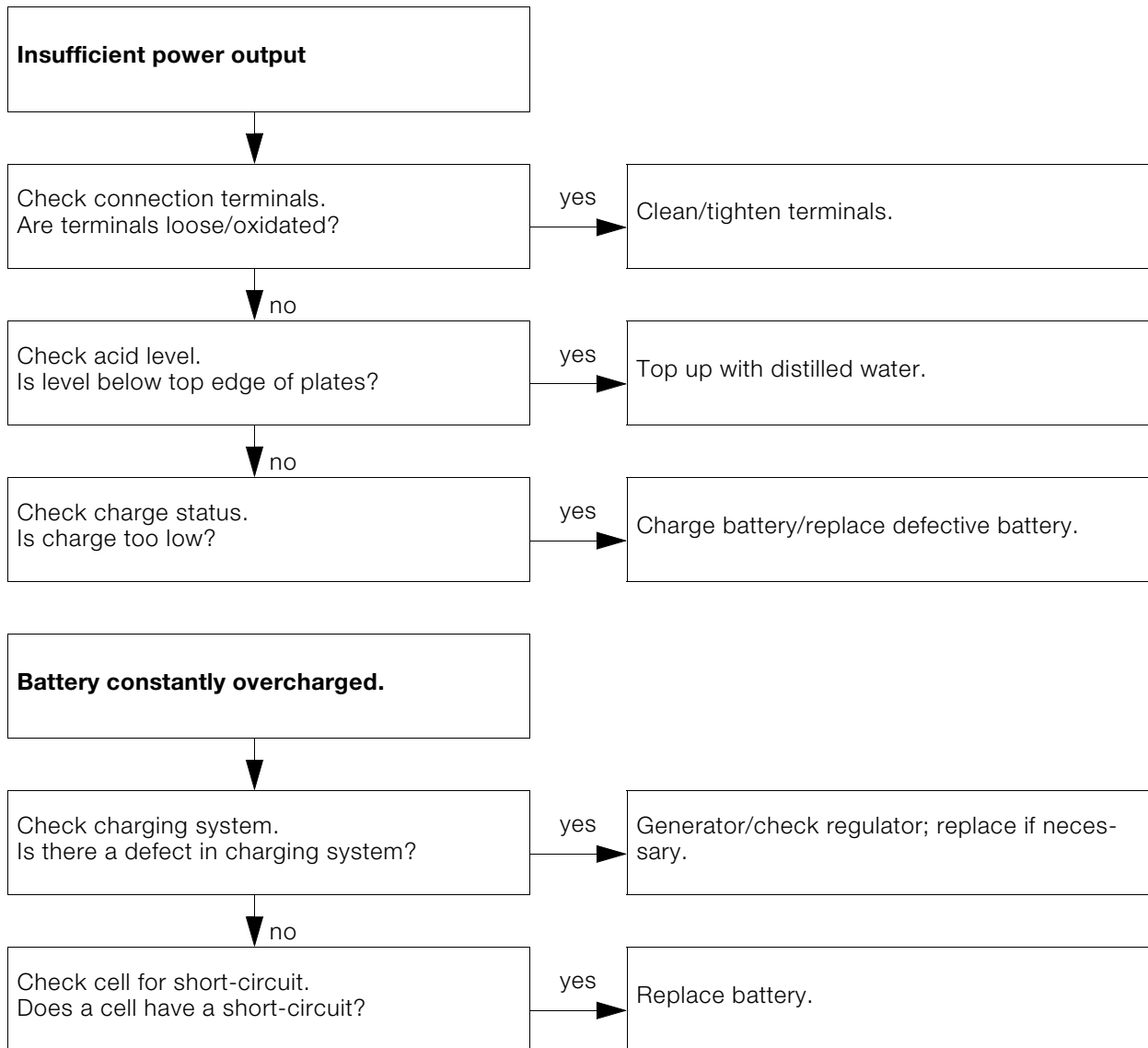



13 Fuel preparation and control

Contents

Page

Technical data	3
Adjusting idle speed	5
Checking start speed increase (choke), adjusting if necessary	6
Checking start speed increase	6
Adjusting start speed increase	6
Adjusting CO value	7
Removing/installing and checking/adjusting throttle position sensor	8
Removing and installing throttle position sensor	8
Checking throttle position sensor	8
Adjusting throttle position sensor	8
Removing and installing air cleaner insert	9
Removing and installing air cleaner housing	10
Removing and installing throttle rail	12
Removing and installing injectors	13
Removing and installing intake stub pipe	13
Removing and installing Motronic control unit	14

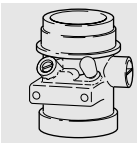

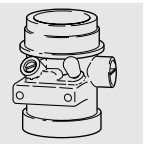

Technical data		K 1100 LS	K 1100 RS
Inside \varnothing of throttle stub pipe	mm (in)	35 (1.37795)	
CO value	% by vol.	1,5 \pm 0,5	
Idle speed	rpm	950 \pm 50	

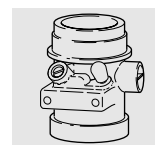

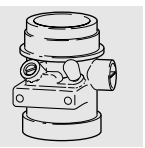

Adjusting idle speed



Note:

The basic setting (ignition, valve clearance) must be correct.

- Remove knee pad.
- Remove left side fairing.

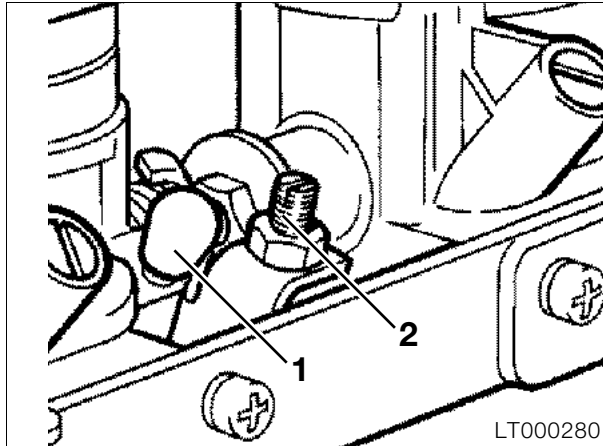

- Remove protective caps (1) at the vacuum connections.
- Connect connection hoses of the Synchrotester, **BMW No. 13 0 800**, one after the other (note hose markings 1-4 on tester housing).
- Connect tester to vehicle with the corresponding adapter lead.
- Start engine and run at a standstill for app. 10 minutes if not already warm.



Caution:

Do not run for more than 20 minutes at a standstill.

- Run the engine at idle speed.
- Select "bar diagram" and maximum resolution.



Note:

If the differences between the individual columns are too great (more than 2...5 mm (0.07874...0.19685 in)), switch over to curve display and compare the individual cylinders with each other; perform fault diagnosis procedure if necessary.

- Repair any faults found.



Caution:

Throttle adjusting screw (2) is secured with lacquer and must not be turned.

- Adjust synchronisation and idle speed by turning the air control screws until the bars/curves are at the same height; adjust engine idle speed.

Idle speed 950 ± 50 rpm

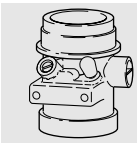

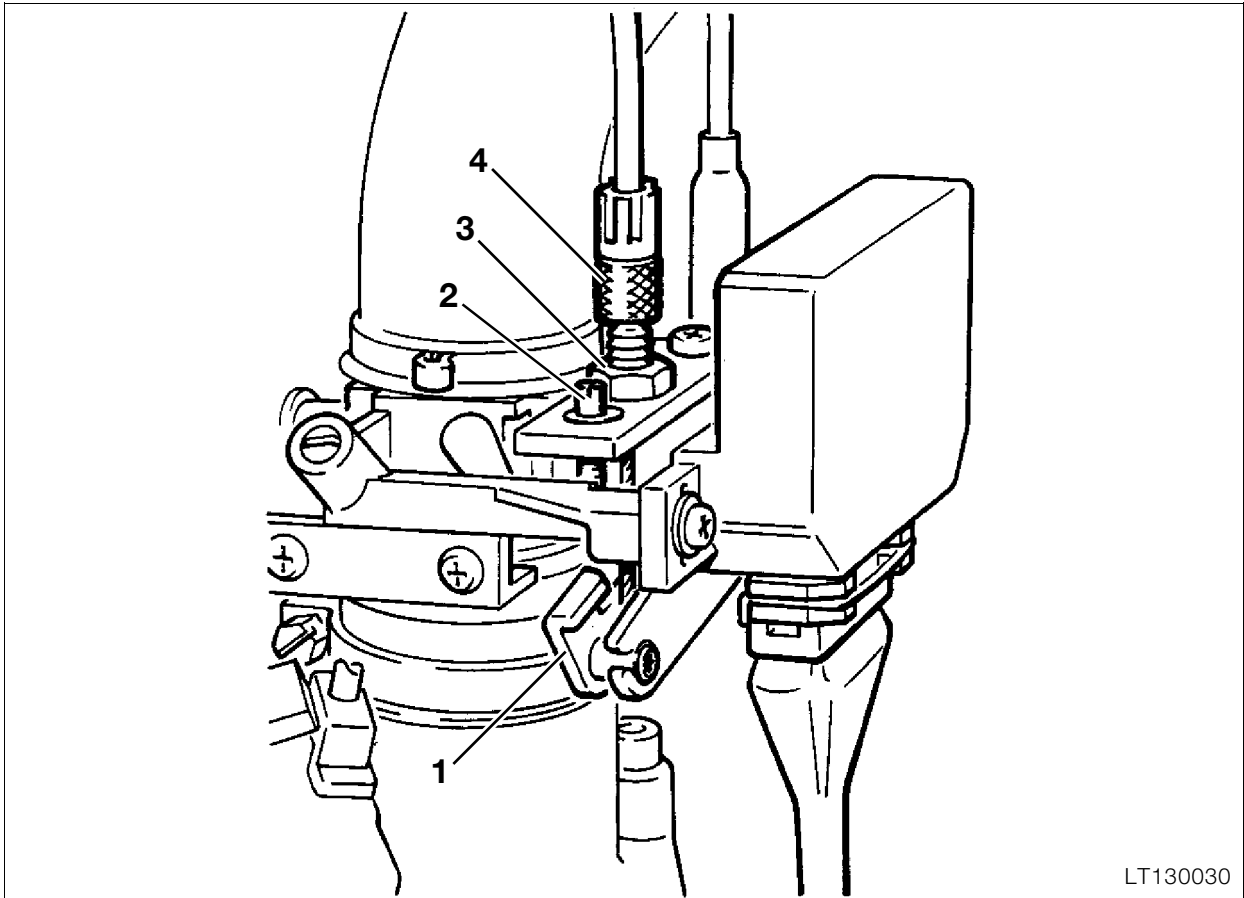

LT130030

Checking start speed increase (choke), adjusting if necessary

Checking start speed increase

- Remove left battery cover.
- Set speed increase to limit stop (stage 2).

⚠ Caution:

Screw (2) is sealed with lacquer and must not be turned.

📄 Note:

Stop face (1) must be in contact with screw (2) and the cable must have no play; if this is not the case, play at the cable must be adjusted.

- Check stop face (1).

Adjusting start speed increase

- Set speed increase to limit stop (stage 2).
- Loosen locknut (3).
- Press lever with stop face (1) against screw (2).
- Turn adjusting screw (4) until there is no play at the cable.
- Retighten locknut (3).

Adjusting CO value

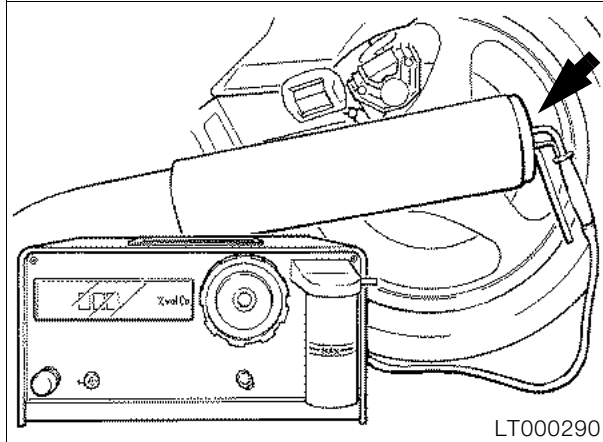

Note:

Engine must be at operating temperature (85 °C). Basic settings (ignition timing, valve clearances) must be correct.

- Insert the measuring probe (arrow) app. **30 cm (12 in)** into the silencer (muffler).

Caution:

Do not perform this measuring work in an enclosed space: risk of asphyxiation.

Note:

If the air extraction equipment is unsuitable, it may falsify the measurement.

- Run the engine at idle speed.

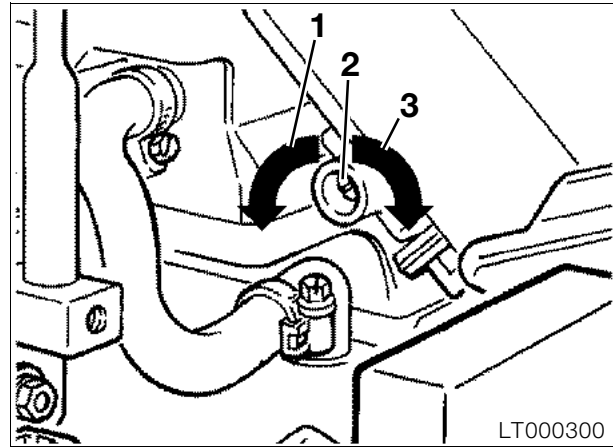

Caution:

Adjusting screw (2) has no limit stop in both directions.

- Turn adjusting screw (2) to obtain correct CO.

Note:

Turn in direction (1) for a richer mixture; the CO value will rise to a maximum. Turning further in direction (1) has no effect on the CO value.

Turn in direction (3) for a leaner mixture; the CO value will drop to a minimum. Turning further in direction (3) will cause the engine's emergency-run programme to operate, but has no influence on the CO value.

Caution:

If the engine's emergency-run programme operates, fault 1111 will be memorised in the engine control unit.

- If necessary, carry out fault diagnosis, rectify the fault and cancel the memory entry.
- Using the BMW Synchrotester, adjust idle speed at the recirculating-air screws.

CO value..... 1,5 ± 0,5 % by vol.
Idle speed950 ± 50 rpm

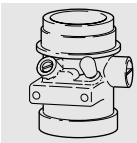

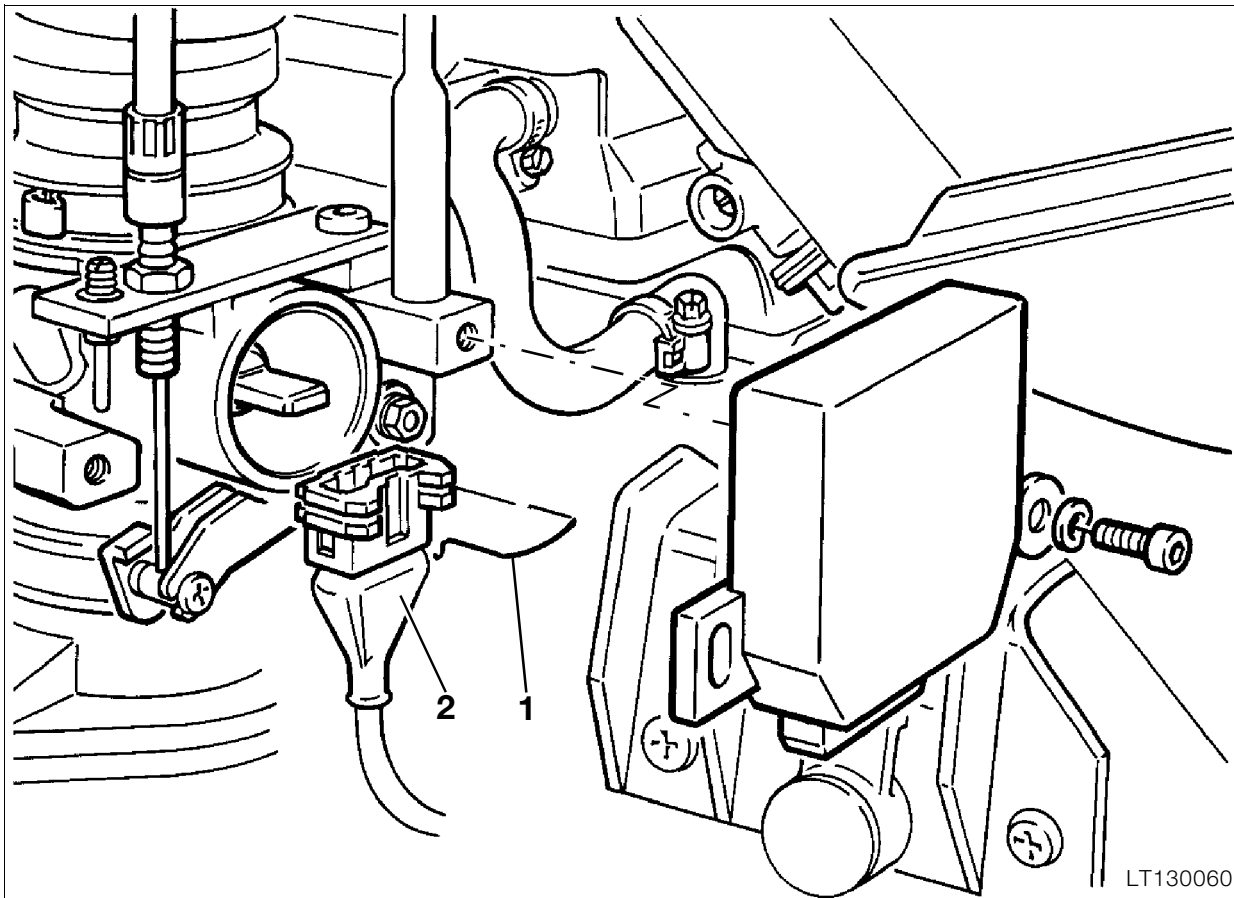

Removing/installing and checking/adjusting throttle position sensor

Removing and installing throttle position sensor

- Unscrew the throttle position sensor and pull it off the throttle shaft.
- Loosen wire keeper (1) and pull off multi-pin plug (2).
- Install in the reverse order of work.



Caution:

If the throttle position sensor has been removed, the basic settings must be checked and corrected if necessary after installing it again.



Note:

See the booklet "BMW Diagnosis, Motronic MA 2.1 with oxygen sensing" or "without oxygen sensing", or the booklet "BMW Diagnosis MA 2.2".

Checking throttle position sensor

- Connect the diagnostic cable.
- Press the left switch on the switch cabinet up to the detent position.
- Switch on the ignition.
- **[MA 2.1]** If the temperature warning light comes on, the throttle position sensor is correctly adjusted.
- **[MA 2.1]** If the temperature warning light does not come on, re-adjustment is needed.
- **[MA 2.2]** If small zeroes are visible on the tester display, the throttle position sensor is correctly adjusted.
- **[MA 2.2]** If no zeroes are visible, check the throttle end stops and re-adjust.

Adjusting throttle position sensor



Note:

Only adjust if the throttle position sensor was removed or renewed.

- Loosen the fastening for the sensor at the throttle rail.
- Turn the sensor to the left or right until **[MA 2.1]** the temperature warning light comes on or **[MA 2.2]** small zeroes appear on the display.
- Tighten the sensor in this position.
- Pull off the diagnostic cable.

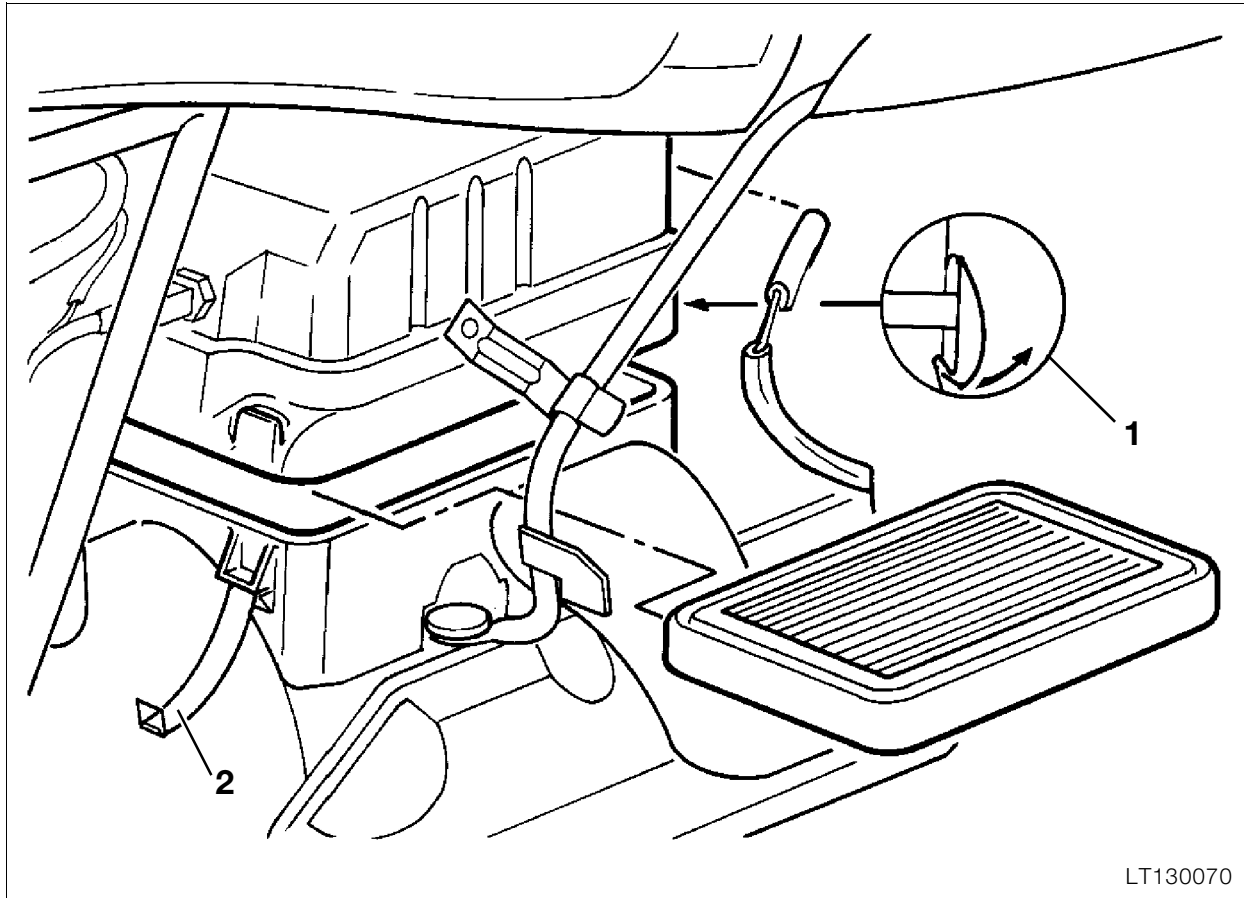

Removing and installing air cleaner insert

- Remove both knee pads.
- Remove fuel tank.
- Remove left and right heat-insulating bulkhead.
- Release front clip (1) and both rear clips (2).
- Slightly raise top section of air cleaner housing and remove air cleaner element.



Note:

Note installed position of air cleaner element: lettering at rear, arrow marking "TOP/OBEN".

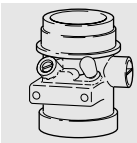

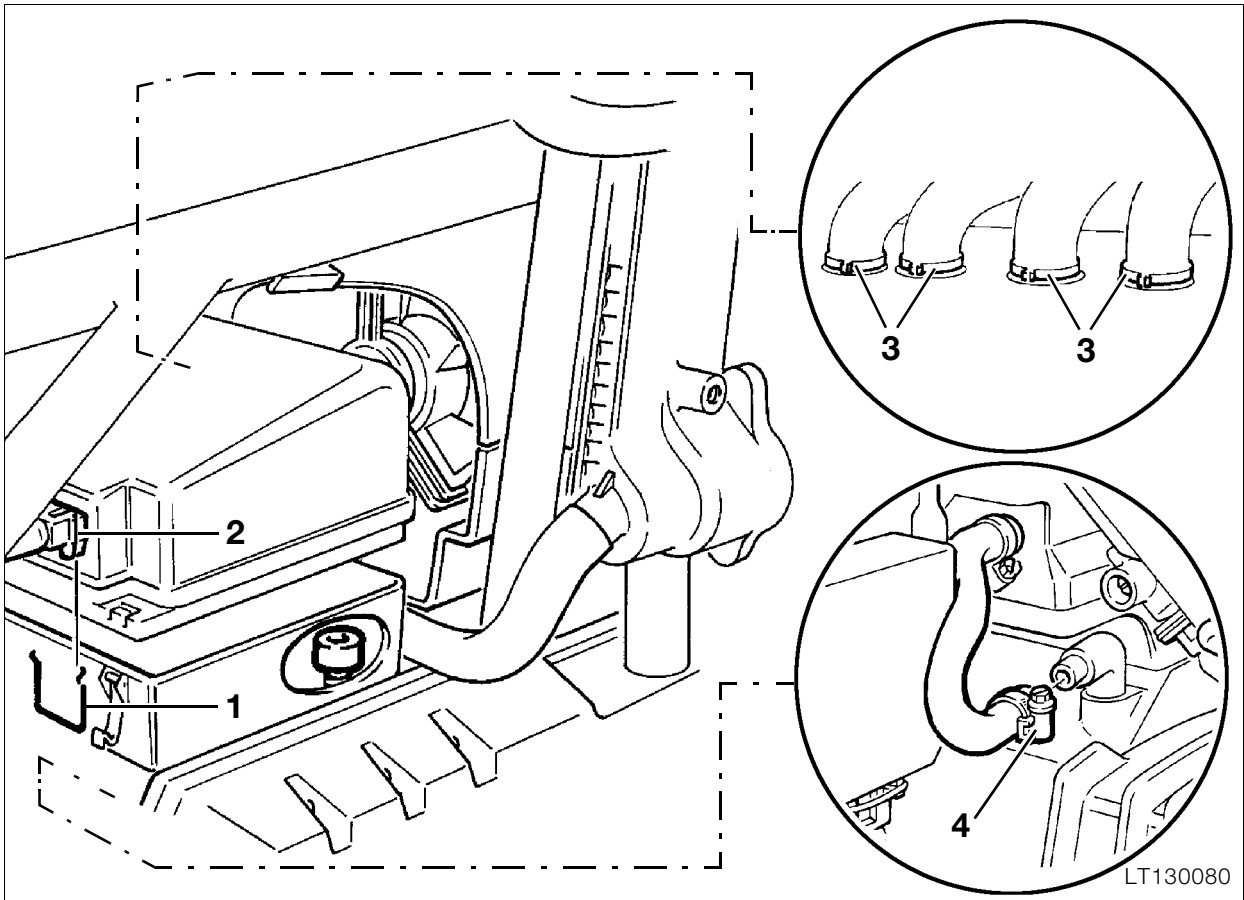

Removing and installing air cleaner housing

- Remove both knee pads.
- Remove fuel tank.
- Remove left and right side fairings.
- Remove intake air guide.
- Remove fairing retaining bracket on right.
- Remove air cleaner.
- Loosen wire retainer (1), disconnect multiplug (2) at air temperature sensor.
- Release hose clips (3) at the air intake lines.
- Loosen hose clip (4), detach crankcase breather ventilation hose.

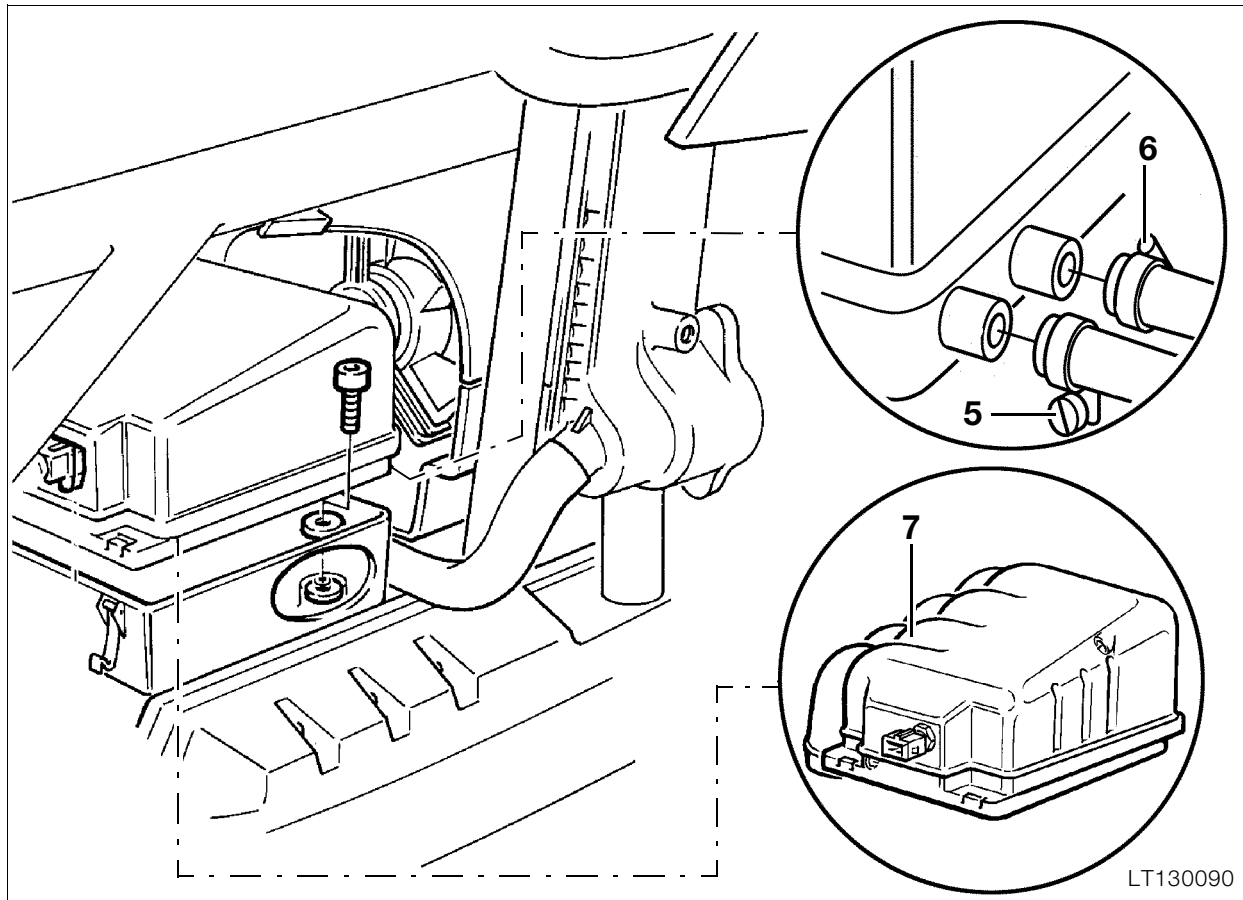

LT130090

- Loosen and pull off oil return pipe (5).
- Loosen and pull off air return pipe (6).
- Pull top section of air cleaner housing (7) out to the right.
- Remove bottom section of air cleaner housing.
- Install in the reverse order of removal.

 **Tightening torques:**

Bottom section of air cleaner housing 21 Nm
 Intake air pipe 9 Nm

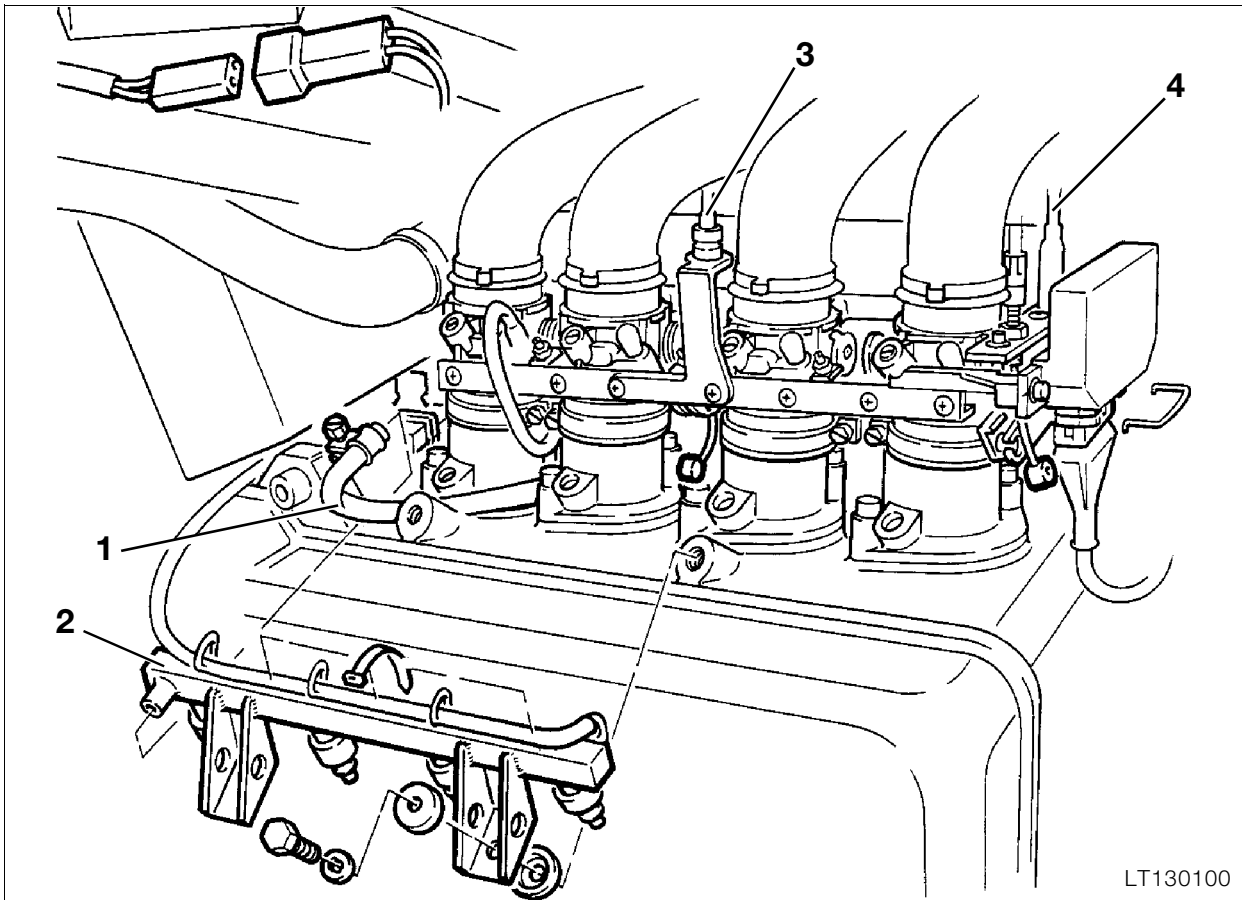

Removing and installing throttle rail

- Remove fuel tank.
- Remove left fairing side section.
- Remove left-hand heat-insulating bulkhead.
- Release fuel hose (1) at injection rail.
- Release injection rail (2) at cylinder head and pull out together with injectors.
- Disconnect multiplug at throttle sensor.



Note:

Only remove throttle sensor if it is to be replaced (basic setting necessary).

- Detach throttle cable (3).
- Detach operating cable (4) for start speed increase.

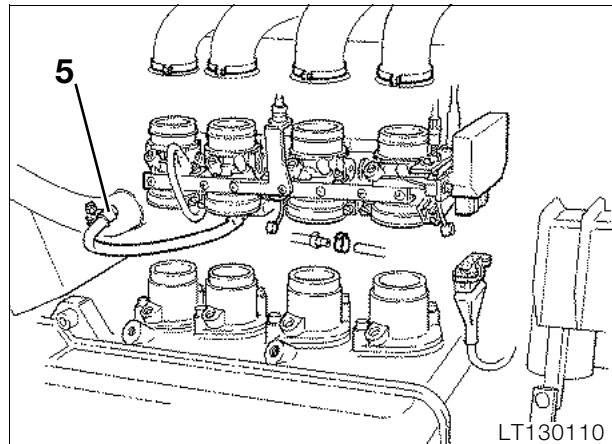

- Release hose clips at the air intake lines, loosen at the throttle coupling.
- Remove throttle rail from stub pipe.
- Pull air return pipe (5) off throttle rail.
- Disconnect indicator lamp plug connection for start speed increase.
- Install in the reverse order of removal.



Note:

Do not change the location of the hose clips on the throttle coupling unions.
Firmly tighten hose clips at the air intake lines with special tool, **BMW No. 31 1 500**.

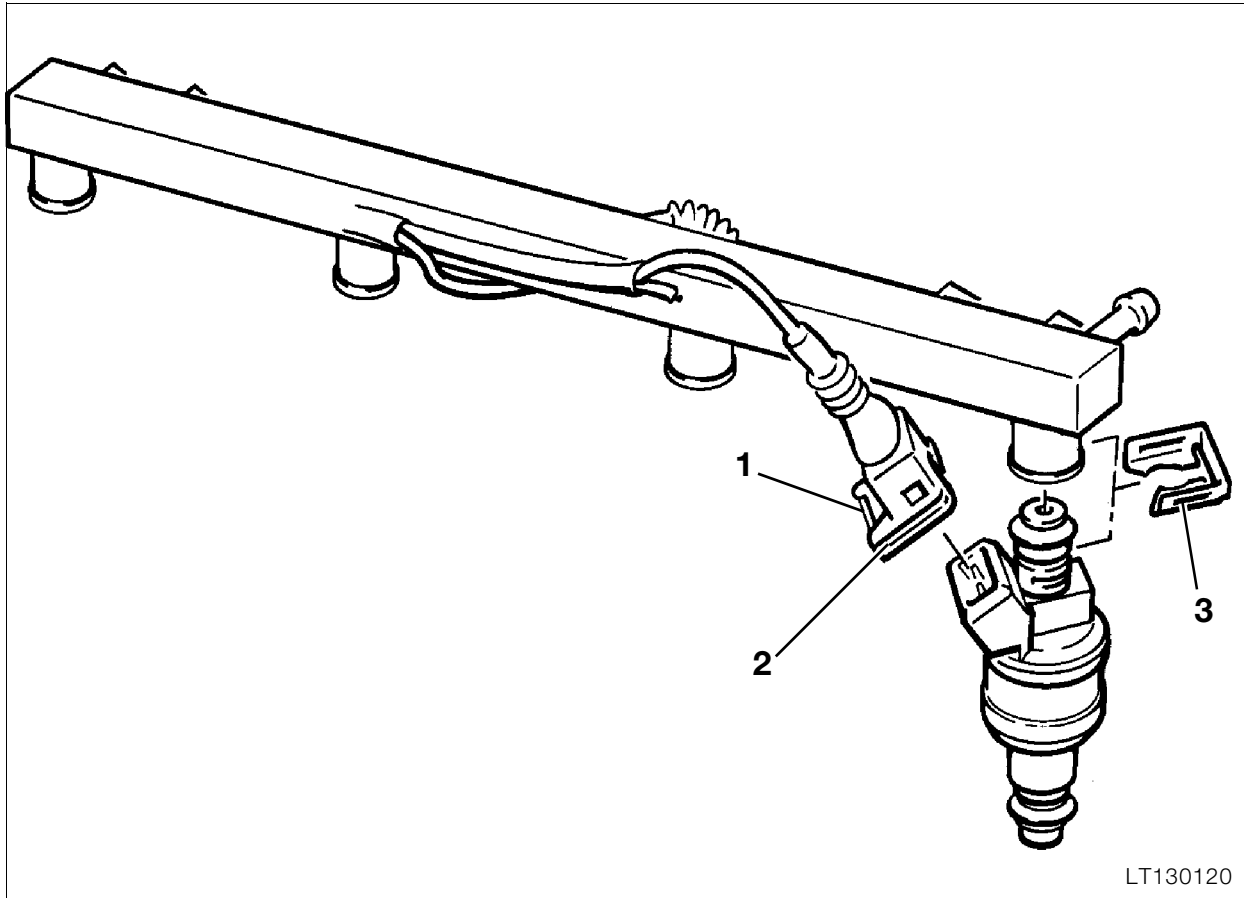

Removing and installing injectors

- Release wire retainer (1) and detach plug (2).
- Release clip (3) at the injector and pull it out.
- Install in the reverse order of removal.



Note:

Ensure that the O-ring on the injector is in good condition!

Removing and installing intake stub pipe

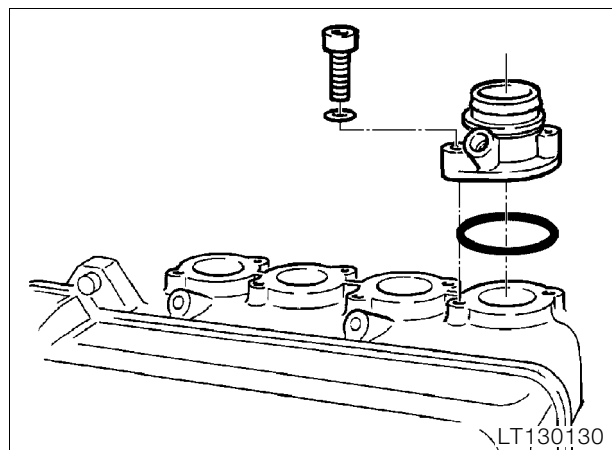

Tightening torque:

Intake stub pipe 9 Nm

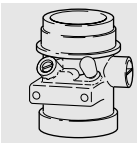

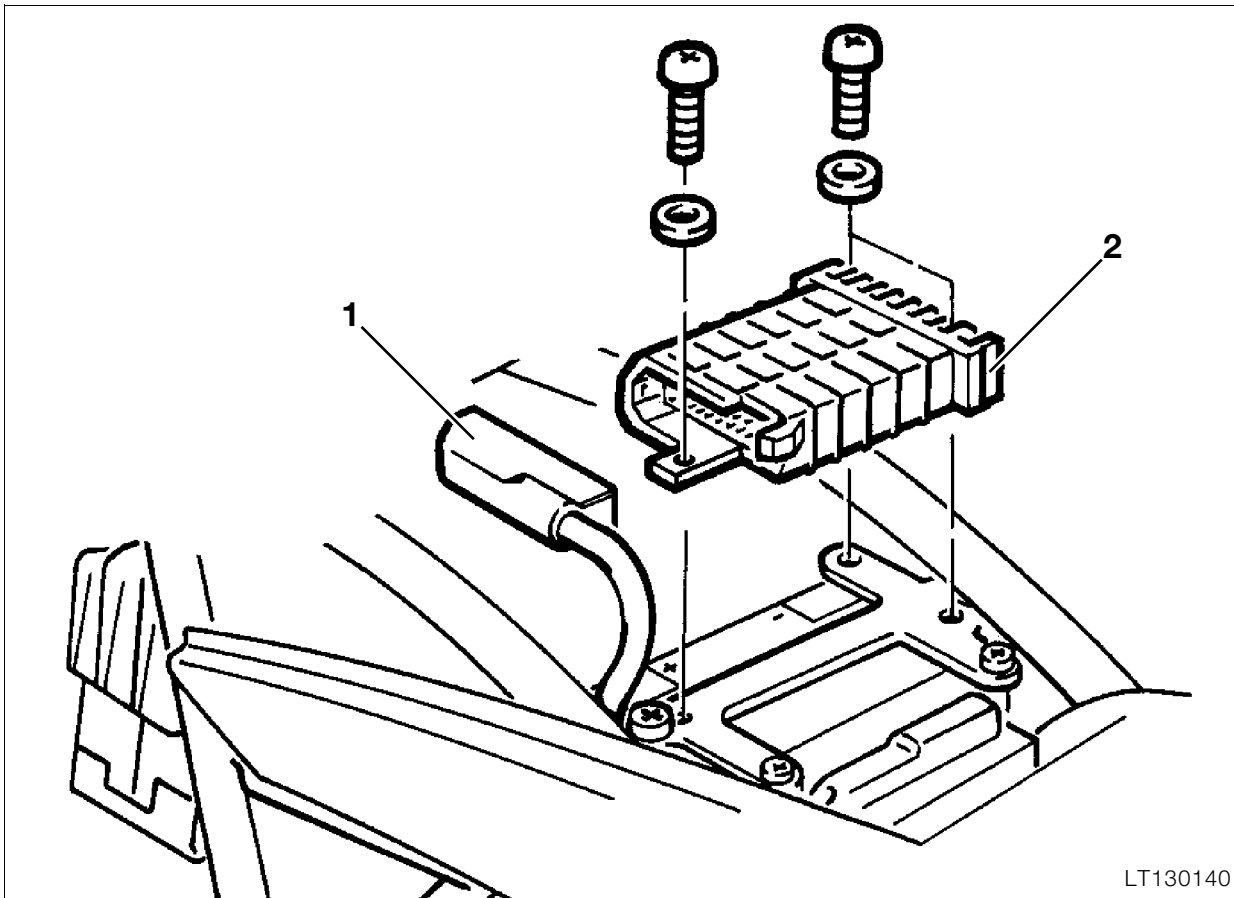

LT130140

Removing and installing Motronic control unit



Caution:

Disconnect earth (ground) lead at battery!

- Release multiplug (1) and disconnect.
- Detach Motronic control unit (2).



Note:

Take particular care when connecting the multiplug to ensure the lock engages.



Tightening torque:

Control unit 5 Nm

16 Fuel tank and lines

Contents

Page

Technical data	3
Removing and installing fuel tank	5
Removing and installing fuel filter	6
Removing and installing fuel level sensor	7
Removing and installing fuel pump	8
Checking fuel pump pressure	9





Technical data		K 1100 LT	K 1100 RS
Fuel tank			
Tank capacity	l (Imp.gal)	22 (4.84)	
incl. reserve capacity	l (Imp.gal)	5 (1.1)	
Fuel pump			
Type		Roller-cell pump	
Make		Bosch	
Operating voltage	V	12	
Fuel pressure	bar (psi)	2.5 (36.26)	
Delivery rate	l/h (gal/h)	45 (9.9)	





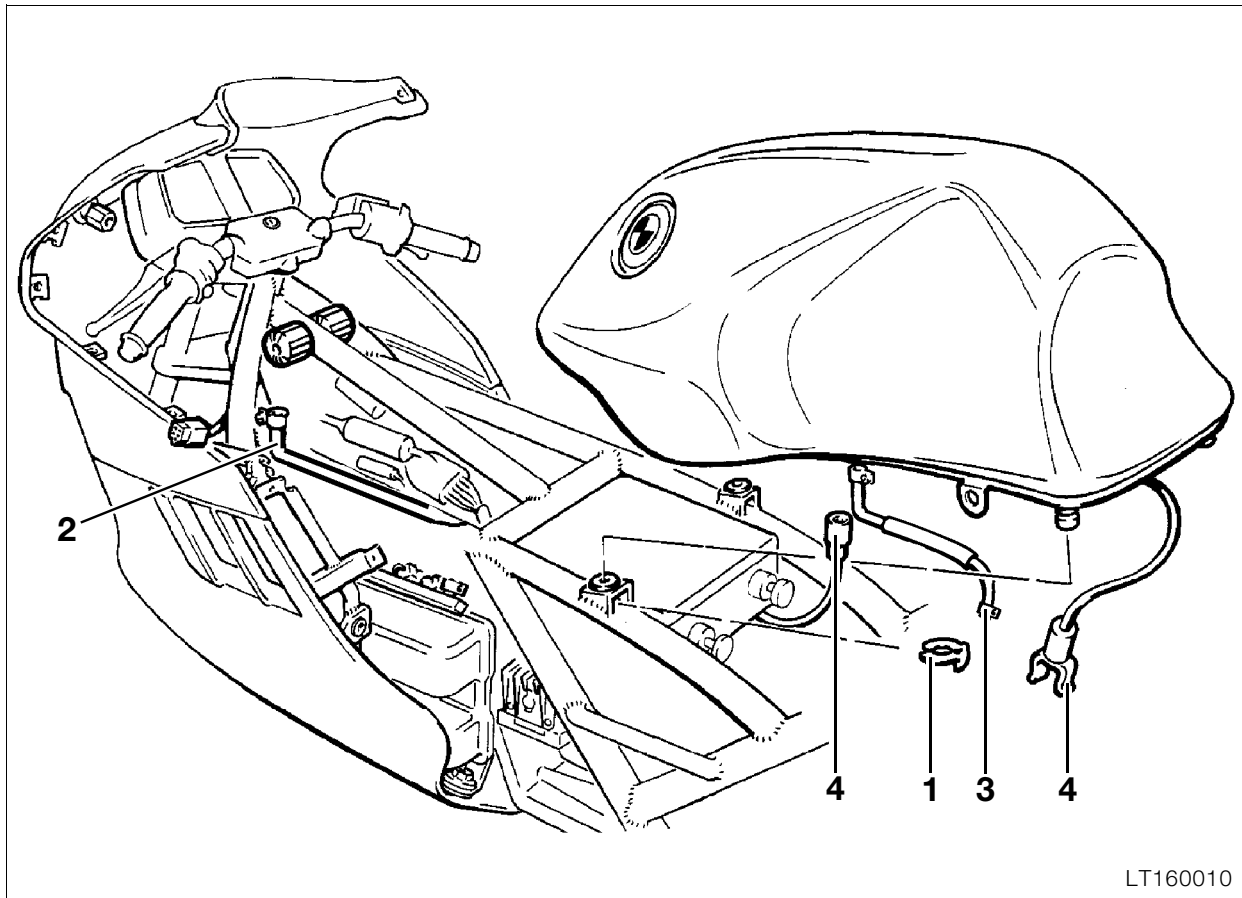

Removing and installing fuel tank

- Open seat.
- Remove left/right knee pads.
- Remove retaining clips (1).
- Release fuel line (2) at fuel tank.
- Release fuel line (3) at injector rail.
- Disconnect plug (4).
- Lift out fuel tank.
- Install in the reverse order of removal.



Note:

To facilitate installation, coat rubber sleeves with tyre fitting paste

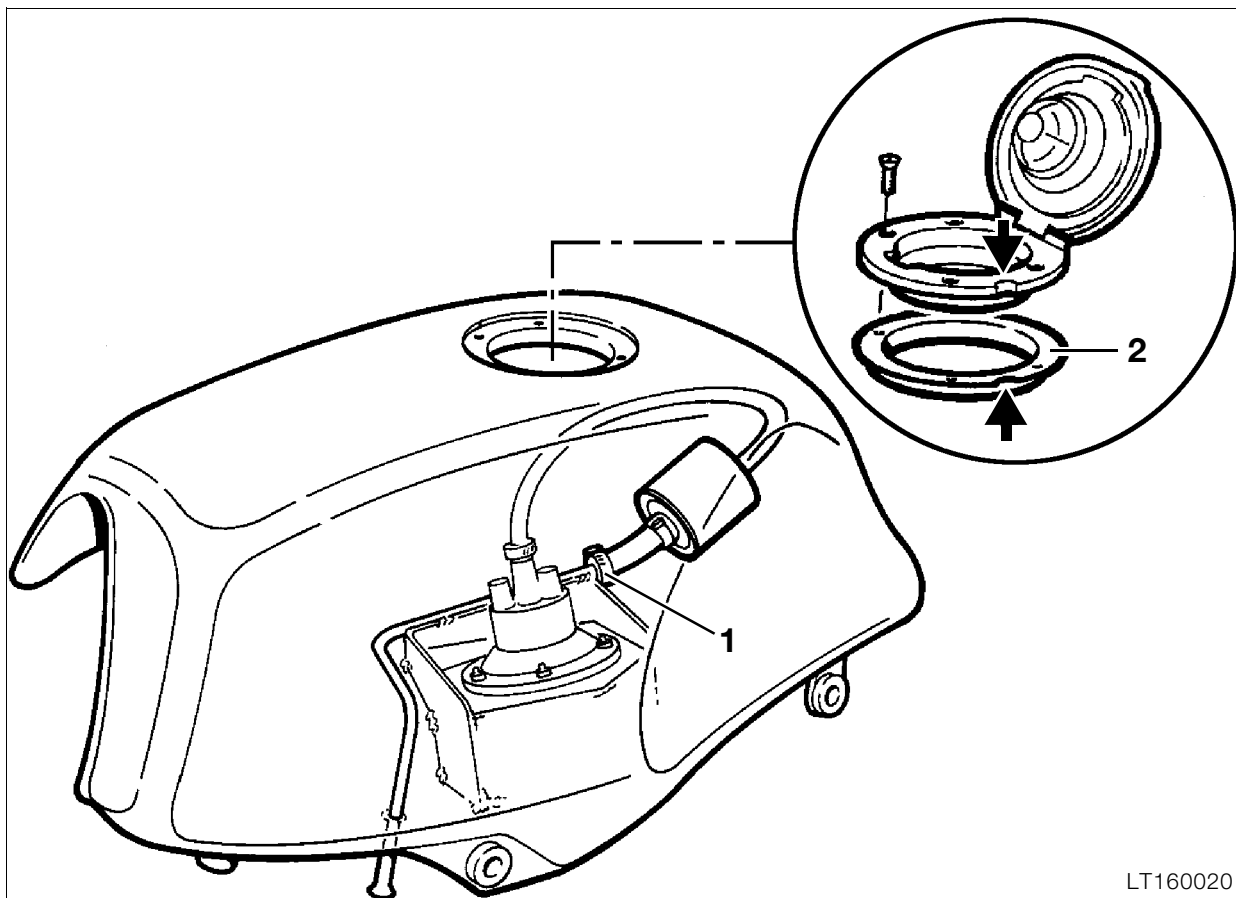

LT160020

Removing and installing fuel filter

- If necessary reduce fuel level with pump until filter is accessible.
- Loosen hose clip (1) and slide towards filter.
- Disconnect line and pull filter with line out of the fuel tank.
- Change fuel filter.



Note:

Note direction of fuel flow on filter.

- Reconnect line to pump.
- Install in the reverse order of removal.



Note:

Gasket (2) must not close off the overflow hole. Note cut-out sections (arrows) in gasket.

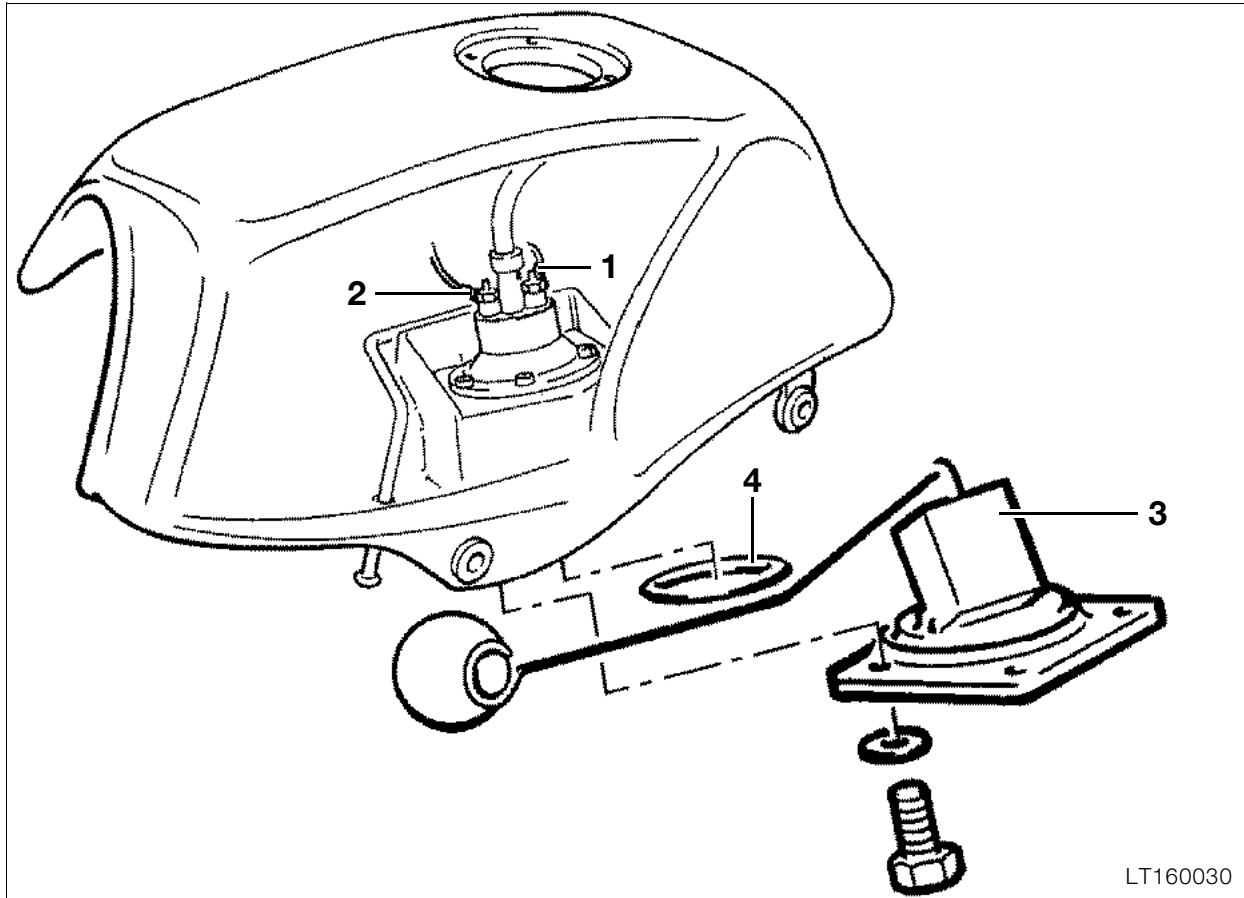

Removing and installing fuel level sensor

- Removing and installing fuel level sensor
- Remove and empty fuel tank.
- Remove filler neck.
- Release electrical connections (1/2) at the fuel pump.
- Pull back insulation a little and remove fuel level pickup (3) from the outside.
- Install in the reverse order of removal.



Note:

Note installation location of gasket (4). Check that the lever moves smoothly.

Electrical connections:

Yellow = +, M 4 connection thread
 Black = -, M 5 connection thread



LT160030

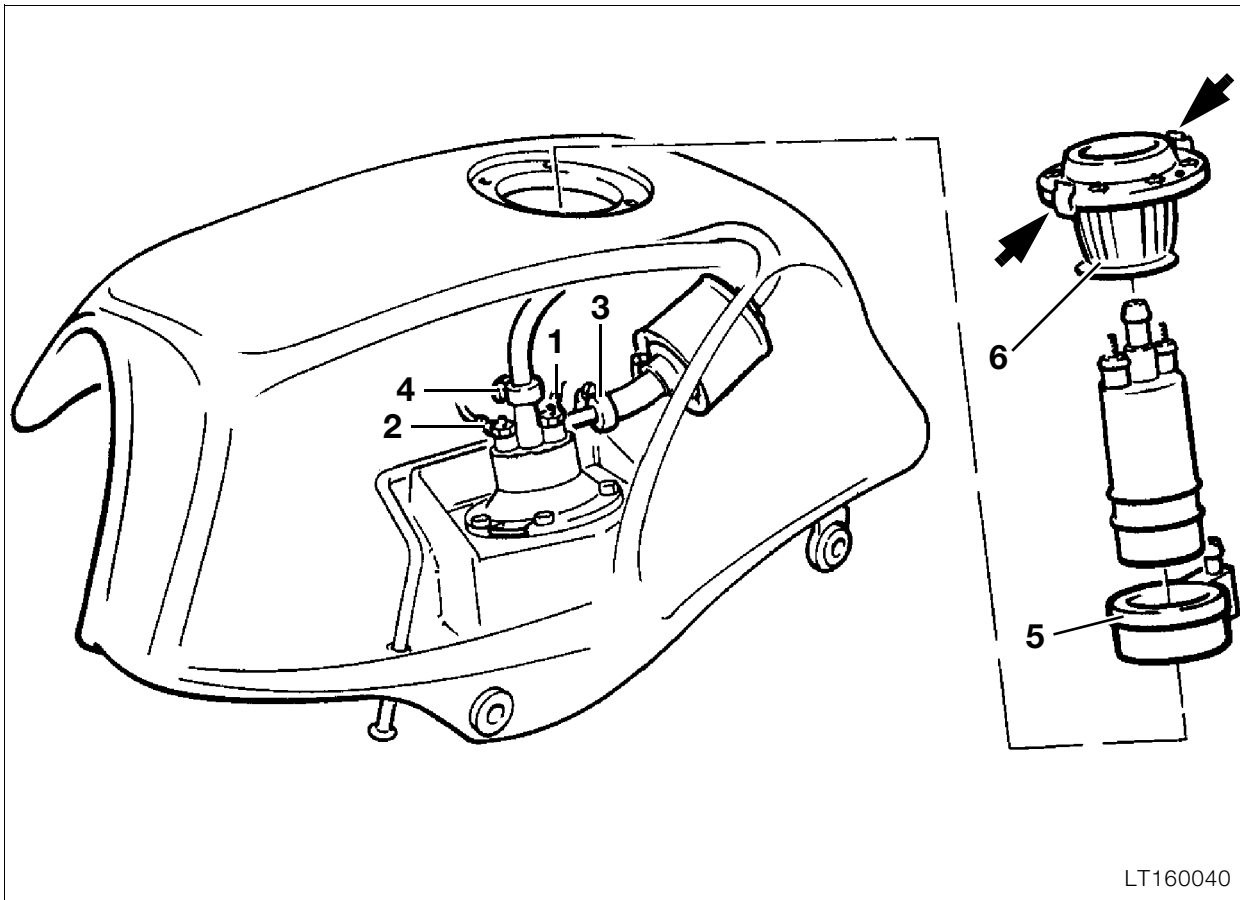

LT160040

Removing and installing fuel pump

- Remove and empty fuel tank.
- Remove filler neck.
- Release electrical connections (1/2) at the fuel pump.
- Release hose clips (3/4) and detach lines.
- Compress clips (arrows) on retaining ring and pull out pump.
- Pull filter (5) off pump.
- Pull off rubber-metal connection (6) together with retaining ring.
- Install in the reverse order of removal.



Note:

The rubber-metal unit must be felt to engage on the fuel pump.

Note position of marking on rubber-metal unit and filter with respect to each other.

Electrical connections:

Yellow = +, M 4 connection thread

Black = -, M 5 connection thread

The positive pole of the fuel pump must face opposite the positive marking on the retaining ring.

Install pump such that both markings are located on the left-hand side of the motorcycle.

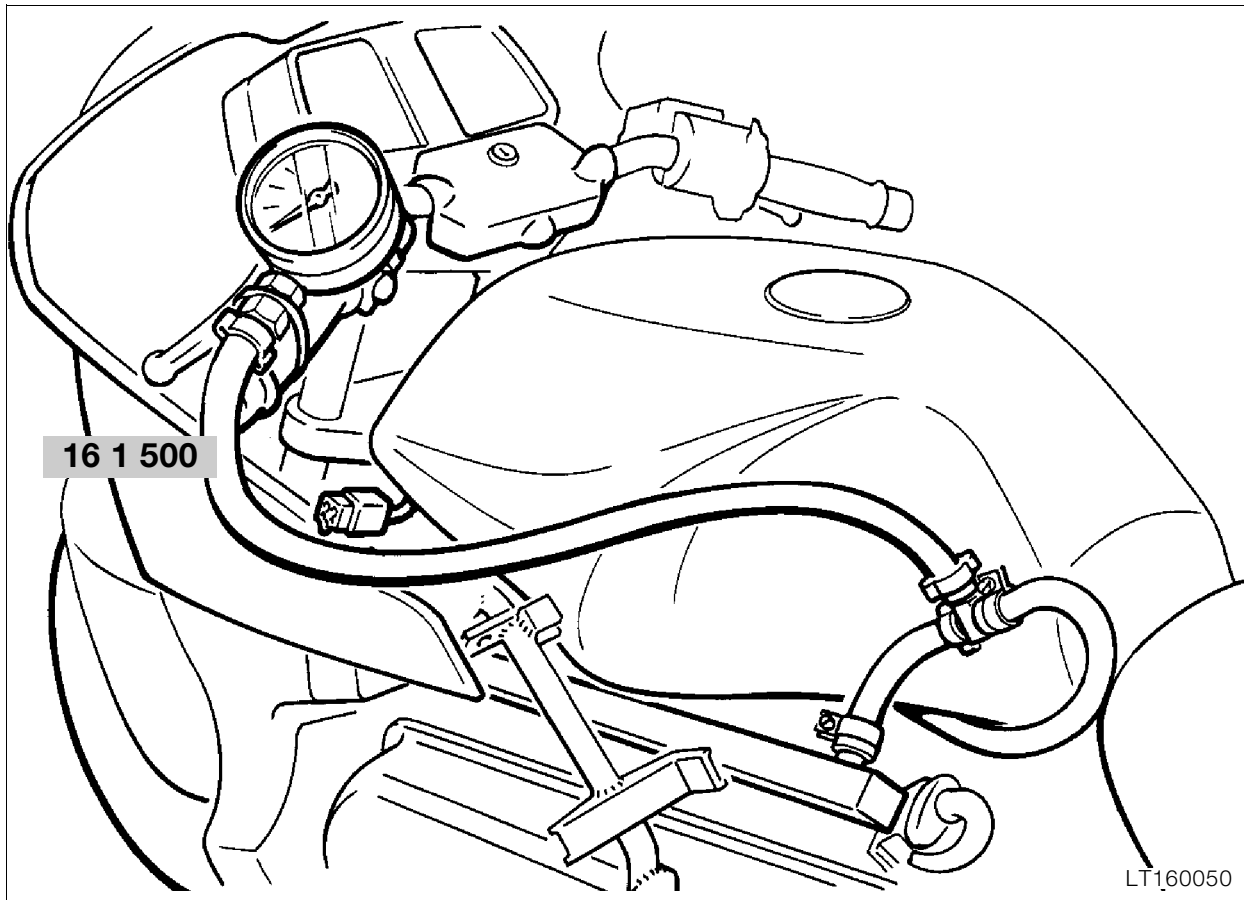

Checking fuel pump pressure

- Connect test pressure gauge, **BMW No. 16 1 500**, on the delivery side.
- Run engine at idle speed.

Fuel pressure:

Nominal value 2.5 bar (36.26 psi)

- If the fuel pressure is lower, check pump, fuel filter and line.



17 Radiator

Contents

Page

Technical data	3
Changing coolant	5
Draining coolant	5
Filling with coolant	5
Removing and installing thermostat	6
Checking thermostat	6
Removing and installing radiator	7
Removing and installing fan	8
Removing and installing coolant hoses	9
Checking cooling system	10
Checking cap for filler neck	10
Checking coolant system for leaks	10
Troubleshooting	11

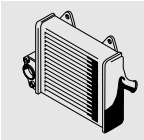

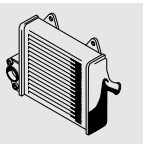

Technical data		K 1100 LT	K 1100 RS
Cooling system capacity	l(imp.gal)	3.0 (0.66) + 0.4 (0.088) in expansion tank	
Coolant Antifreeze Water	% %	Concentration (down to - 28 °C) 40 60 Only use nitride-free long-term frost and corrosion protection agents	
Thermostat opens at	°C	85	
Cut-in temperature for fan	°C	105	
Cut-in temperature for coolant warning lamp	°C	115	
Pressure relief valve in cap opens at	bar (psi)	1.0 = 120 °C (14.504 = 120 °C)	
Vacuum valve in cap opens at	bar (pis)	- 0.1 (-1.4504)	

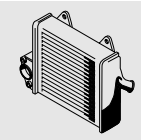

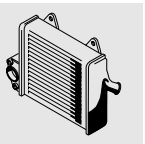

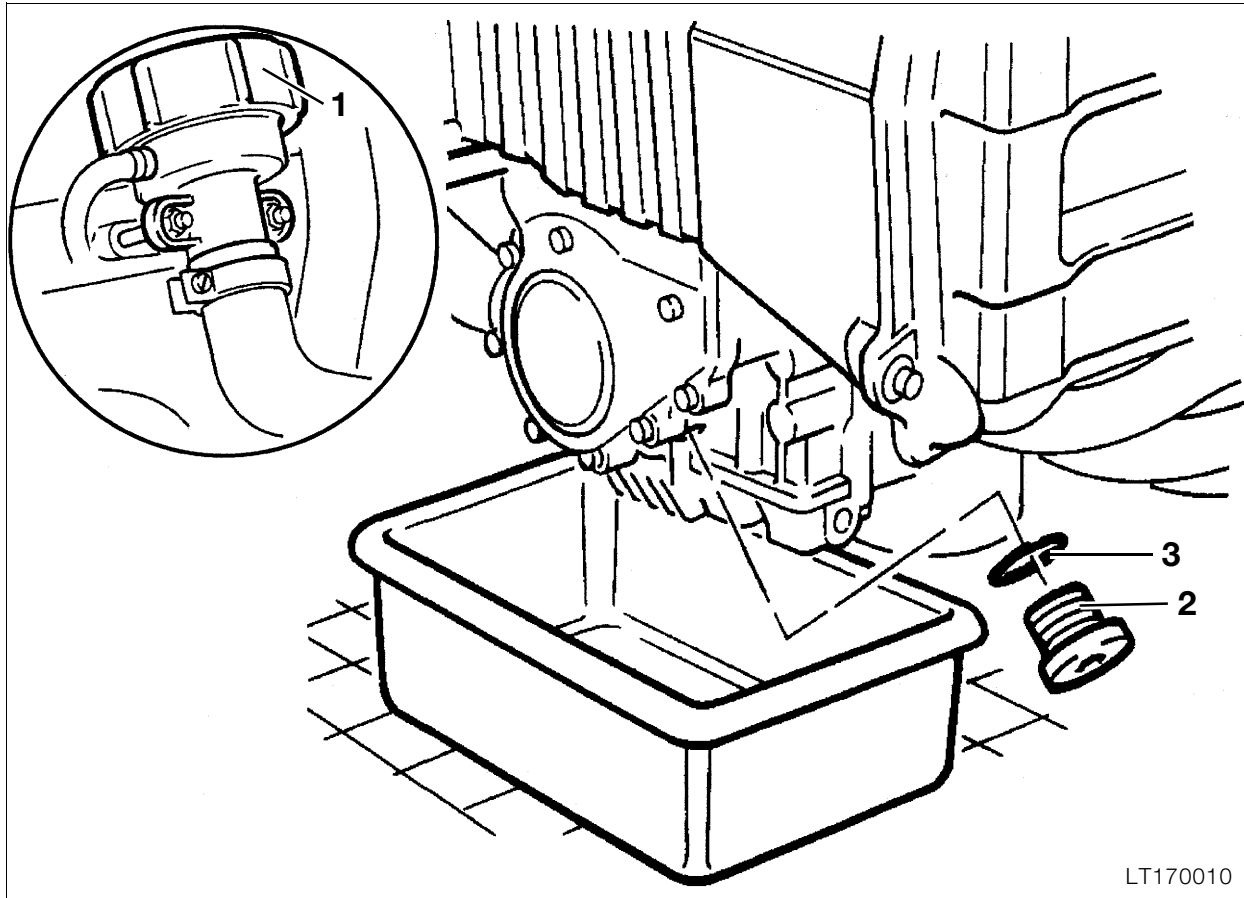

LT170010

Changing coolant

Draining coolant

- Remove fuel tank.
- Release cap (1) on filler neck.
- **[RS]** Remove lower section of fairing
- Release screw plug (2) on water pump **[RS]** , or water temperature sensor **[LT]**.
- Note gasket.

 **Tightening torque:**
 Drain plug, temperature sensor 9 Nm

Filling with coolant

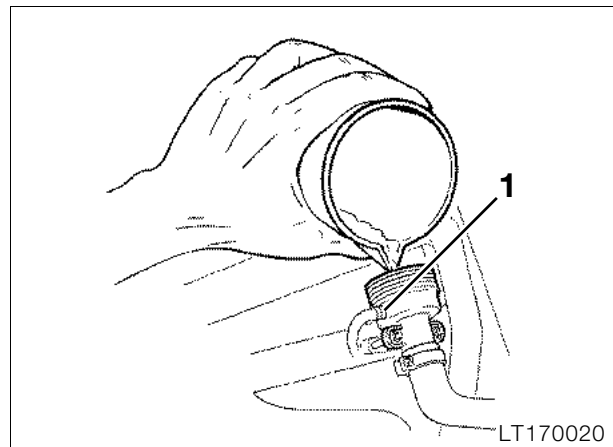

LT170020

- Fill with coolant up to lower edge of filler neck (1).

Coolant:

Concentration (down to - 28 °C)

Antifreeze 40 %

Water 60 %

Capacity 3.0 l (0.66 Imp.gal)

Quantity in expansion tank 0.4 l (0.088 Imp.gal)

- Crank engine with starter while kneading hose between water pump and filler neck
- Assemble motorcycle.

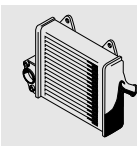

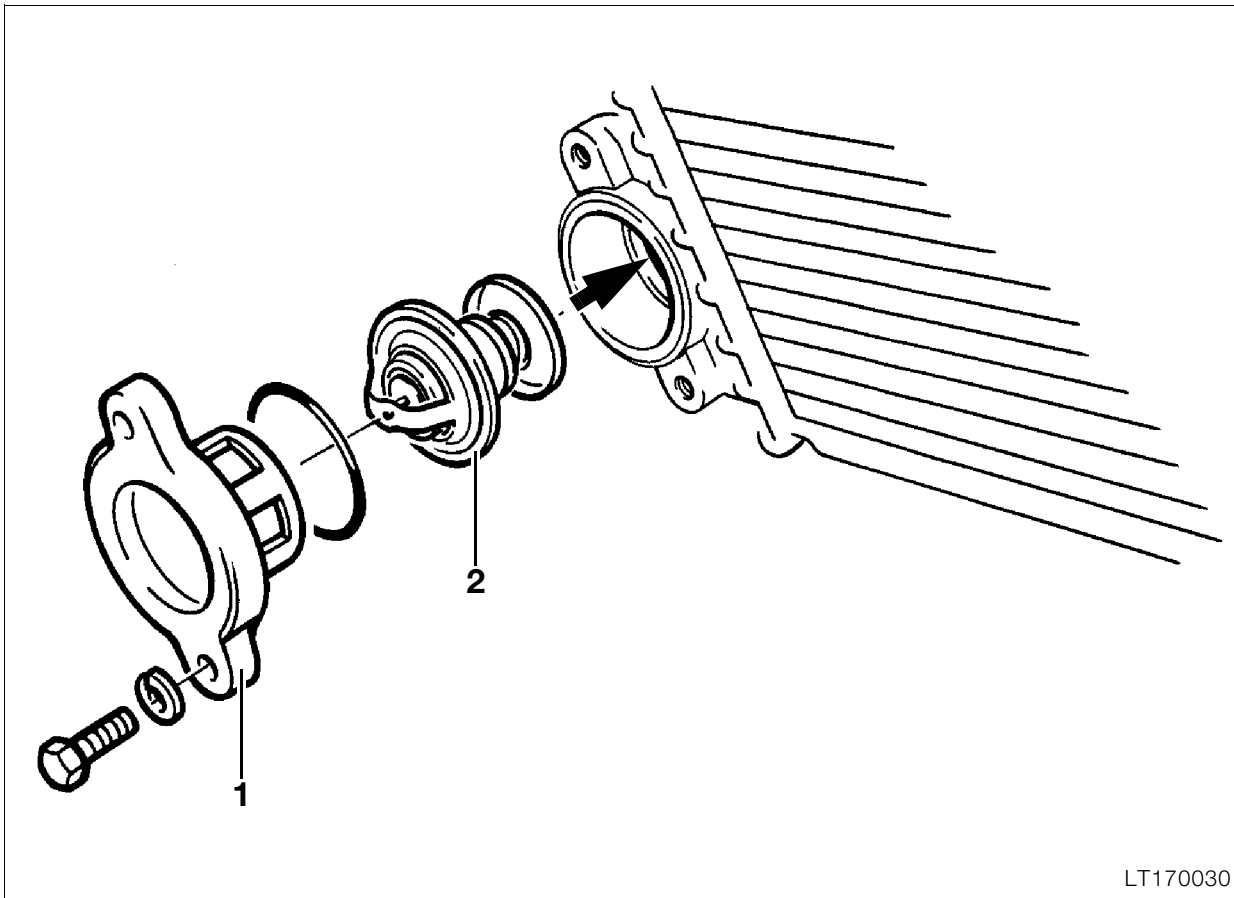

LT170030

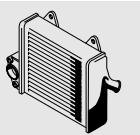

Removing and installing thermostat

- Remove fuel tank.
- Remove right side section of fairing.
- Remove radiator cowling.
- Remove cover (1).
- Pull out thermostat (2).

Checking thermostat

- Heat up thermostat in water bath.
- Check start of opening and fully open setting.

Opening temperature:

Start of opening 85 °C
 Fully open 105 °C

- Install in the reverse order of removal.



Tightening torque:

Cover 3 Nm

- Top up coolant in the corresponding concentration.

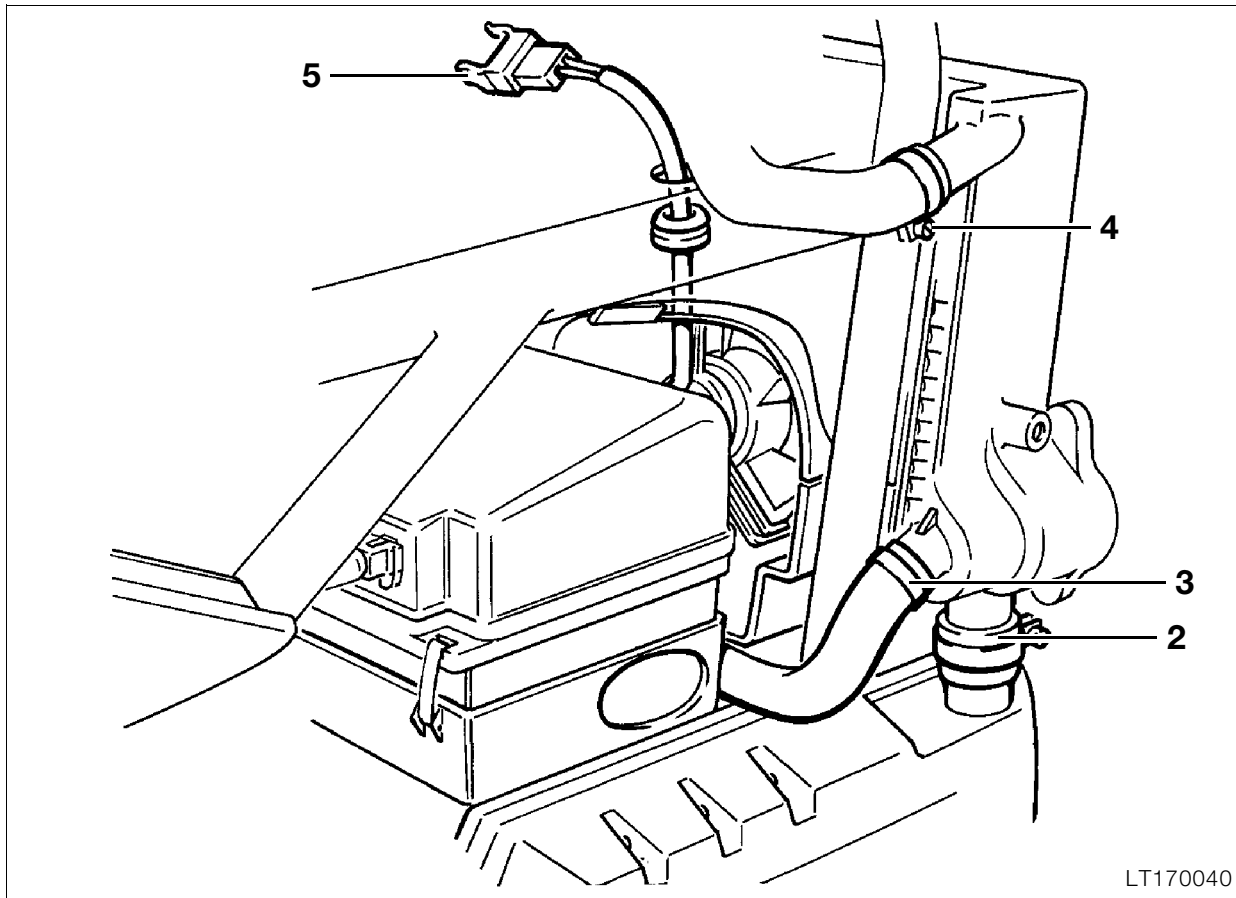

LT170040

Removing and installing radiator

- Remove fuel tank.
- **[RS]** Remove bottom section of fairing
- Remove left/right side fairing.
- Remove radiator cowl.

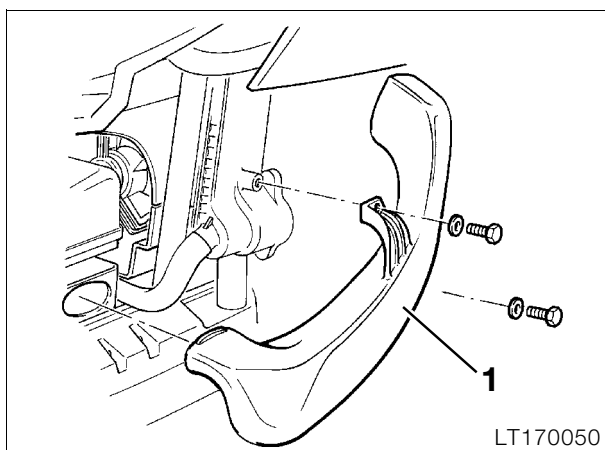

LT170050

- Remove air line (1).

- Release connections (2,3,4) of the coolant hoses.
- Disconnect plug connection (5) for fan motor.

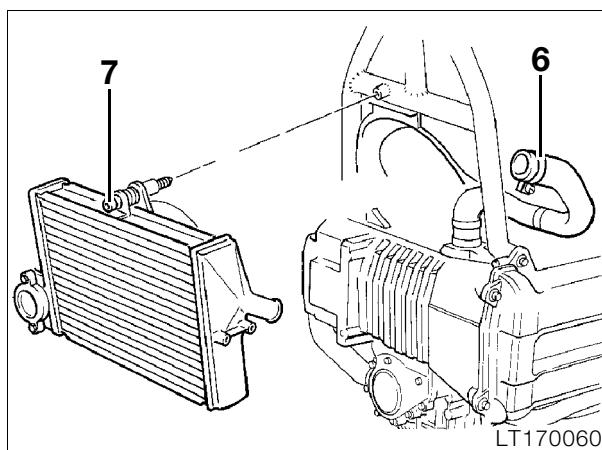
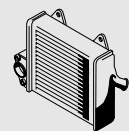

LT170060

- Release hose connection (6) and mounting (7) for radiator.
- Install in the reverse order of removal.



Tightening torque:

Radiator 9 Nm

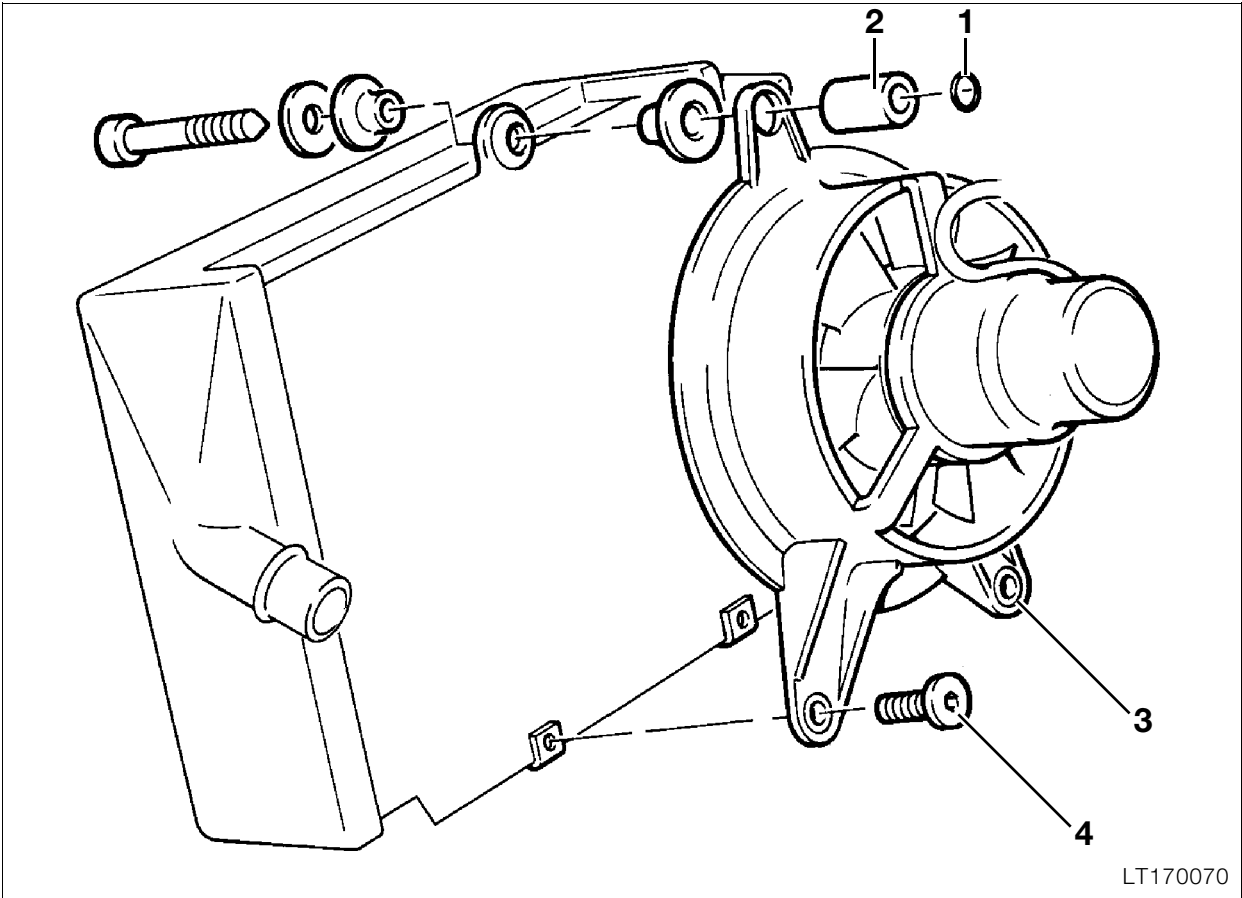

LT170070

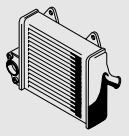

Removing and installing fan

- Remove radiator.
- Remove rubber ring (1) and spacer bush (2).
- Release retaining bolts (3, 4).
- Install in the reverse order of removal.

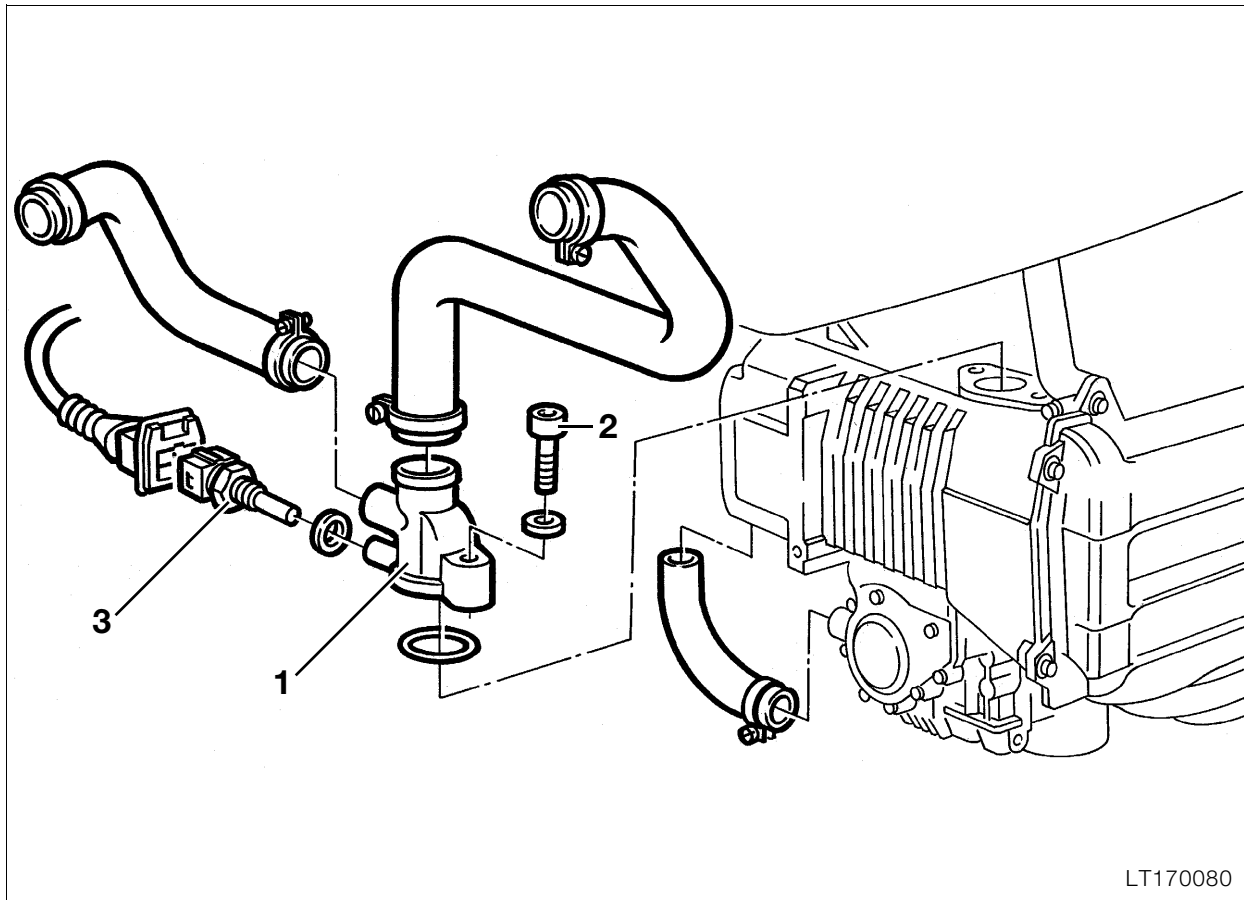

Removing and installing coolant hoses

- Remove fuel tank.
- **[RS]** Remove bottom section of fairing .
- Remove left/right side fairings.
- Remove corresponding coolant hose.
- Remove radiator in order to release connections on coolant filler neck (1).



Note:

Before screwing back in, clean the thread of micro-encapsulated screw (2) and secure it with **Loctite 243**.



Tightening torques:

Coolant filler neck to cylinder head (2) 9 Nm
 Temperature sensor to coolant filler neck (3) 30 Nm

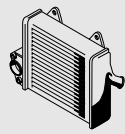

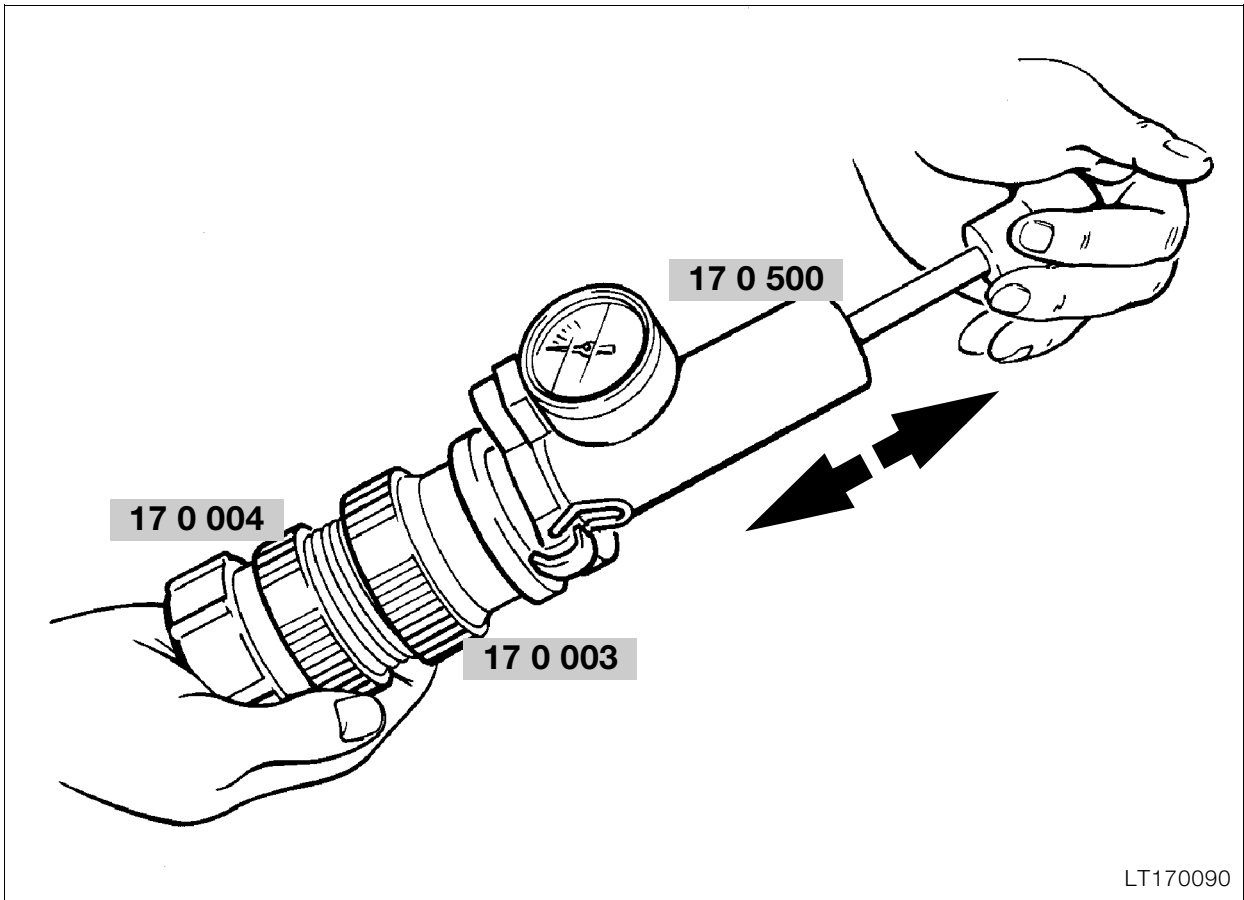

LT170090

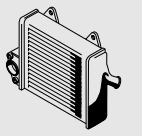

Checking cooling system

Checking cap for filler neck

- Remove fuel tank.
- Connect adapter (1), **BMW No. 17 0 003**, to pump, **BMW No. 17 0 500**.
- Screw cap onto screw coupling (2), **BMW No. 17 0 004**, and connect to pump.
- Pressure test cap.

Pressure relief valve opens at.. 1.5 bar (21.756 psi)

Checking coolant system for leaks

- Screw pump, **BMW No. 17 0 500**, with adapter and screw coupling to filler neck.
- Apply pressure to cooling system; pressure must remain unchanged for at least 10 minutes.

Test pressure 1 bar (14.504 psi)

- Install in the reverse order of removal.

Troubleshooting

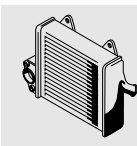
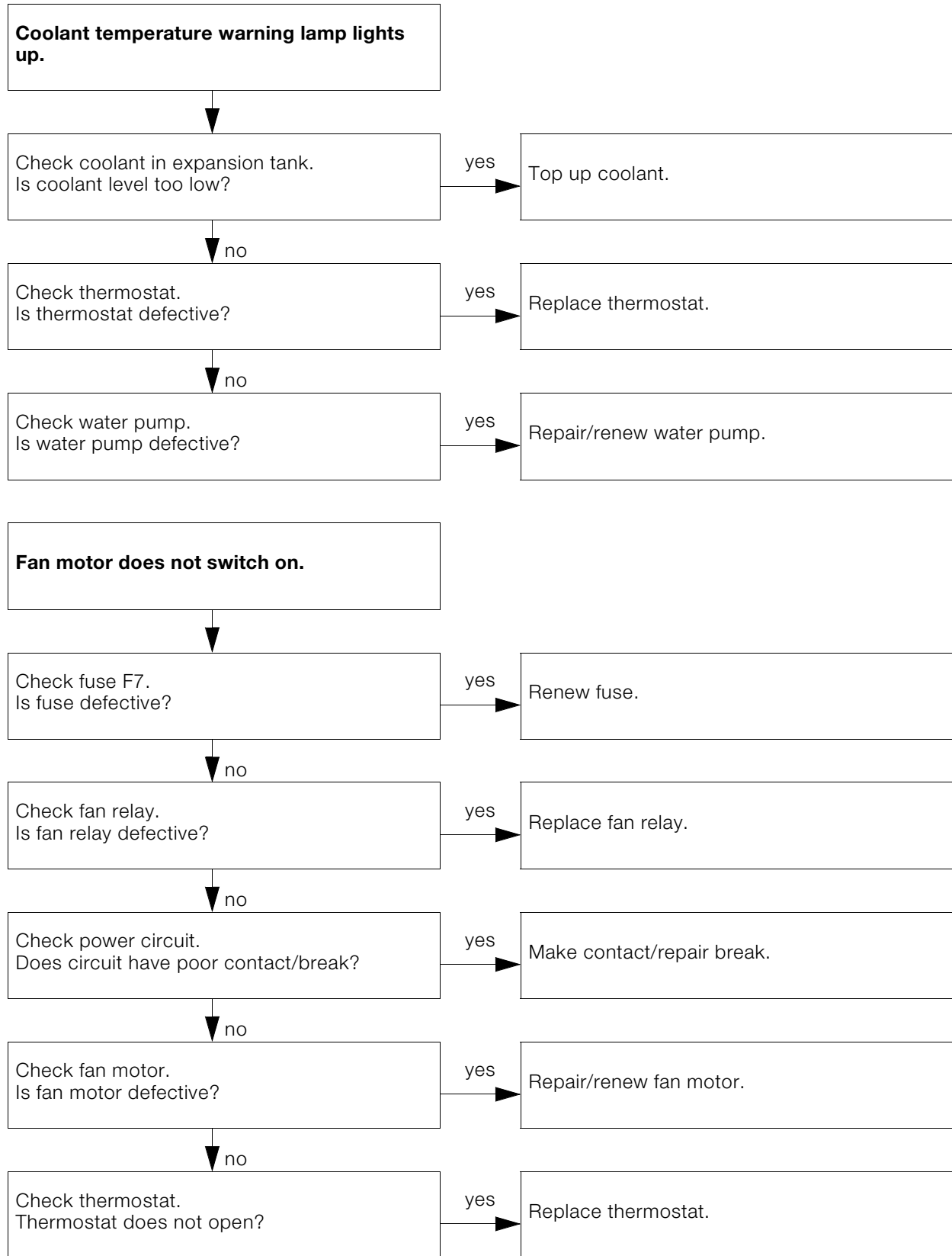

Übermäßiger Kühlmittelverlust.



Check coolant circuit.
Has coolant circuit a break?

yes

Repair break.

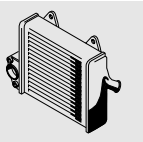

18 Exhaust system

Contents

Page

Removing and installing exhaust system	3
Removing and installing oxygen sensor	4

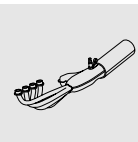

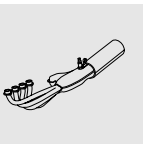

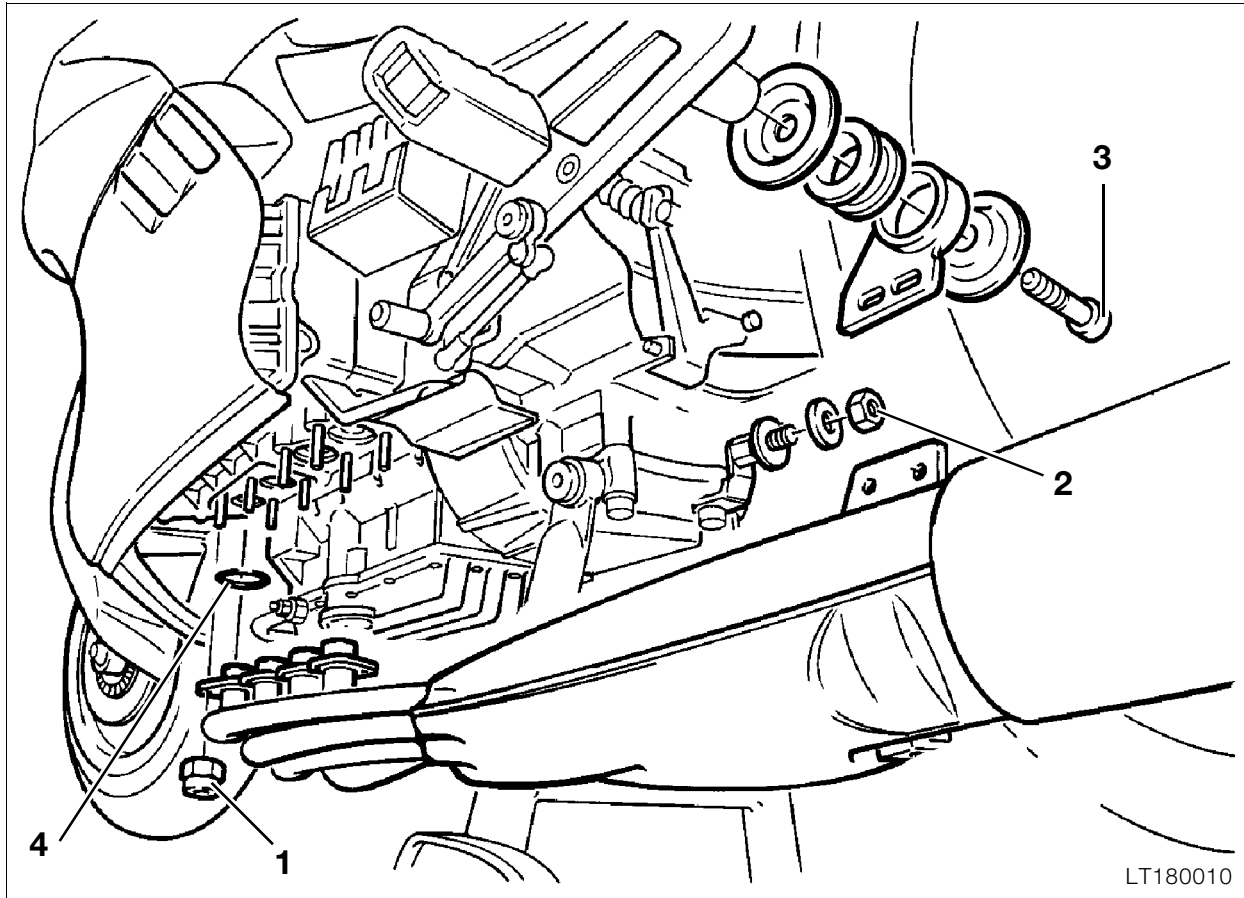

Removing and installing exhaust system

- Release mounting (1) on cylinder head.
- Release mounting (2) on transmission.
- Release mounting (3) on footrest plate.
- **[CAT]** - Detach plug connection for oxygen sensor.



Note:

Use new sealing rings (4) during installation.



Tightening torques :

Exhaust system to cylinder head.....	21 Nm
Front silencer (muffler)	12 Nm
Exhaust system holder to footrest plate	33 Nm
Exhaust system to holder/footrest plate	9 Nm
Retaining bracket to gearbox	41 Nm

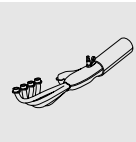

Removing and installing oxygen sensor

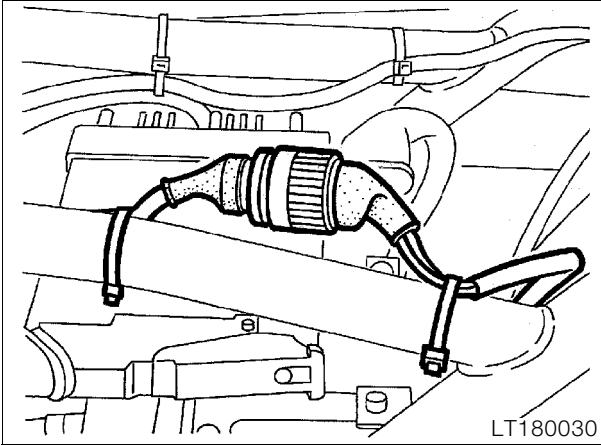

- Separate plug connection for oxygen sensor.

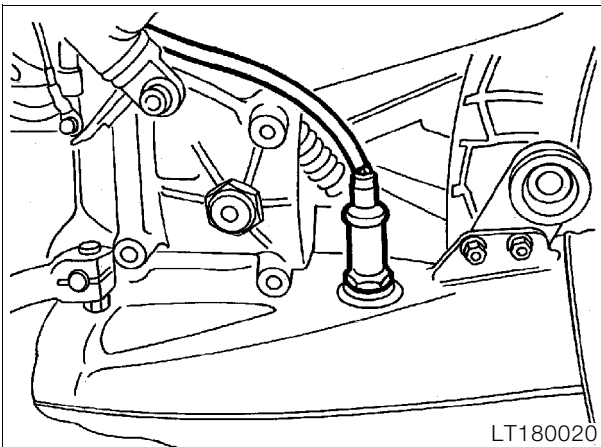

- Remove left footrest plate.
- Unscrew oxygen sensor at hexagon.



Note:

Before installing, coat thread of oxygen sensor with **Optimoly TA**.



Caution:

Read out Motronic defect code memory after test run!



Tightening torque:

Oxygen sensor..... Hand-tight

21 Clutch

Contents

Page

Technical Data	3
Removing clutch	5
Removing clutch housing	7
Installing clutch housing	8
Installing clutch	9
Adjusting clutch clearance	11
Removing and installing clutch thrust bearing	12
Removing and installing clutch control rod	13
Removing and installing clutch release lever	14
Troubleshooting	15

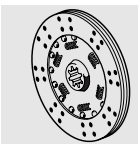

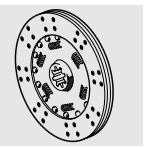

Technical Data		K 1100 LT	K 1100 RS
Type of clutch		Single dry plate clutch with diaphragm spring	
Outside- \varnothing of diaphragm spring	mm (in)	180 (7.0866) \pm 1 (0.039379)	
Total thickness of driving disc (disc and lining)	mm (in)	5.3 (0.20866) \pm 0.25 (0.00984)	
Minimum thickness of driving disc	mm (in)	4.5 (0.177165)	
Clutch clearance at handlebar lever	mm (in)	4.0 (1.5748) \pm 0.5 (0.19685)	
Operating cable length at clutch release lever	mm (in)	75 (2.95275) \pm 1 (0.03937)	



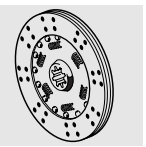

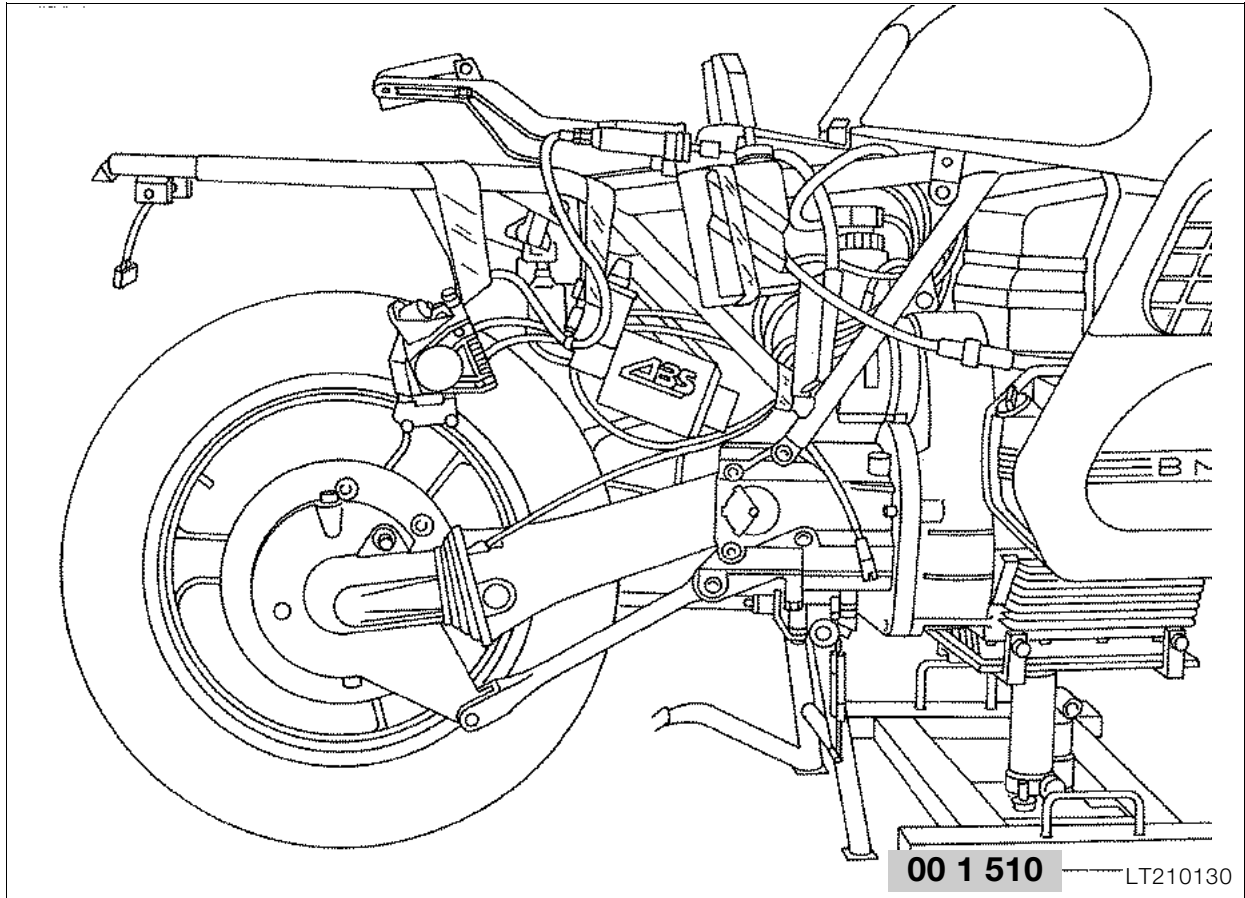

Removing clutch

- Secure lifting gear, **BMW No. 00 1 510**, to the oil sump.
- Remove main stand.
- Remove rear mudguard.
- Remove right-hand footrest plate.
- Remove Motronic control unit.
- Remove battery.
- **[ABS I]** Remove ABS control unit.
- **[ABS I]** Secure pressure modulators to rear section of frame.
- **[ABS II]** Remove ABS unit.
- **[ABS I]** Remove holder for demodulators.
- Release bottom retaining bolts (1) holding transmission.
- Re-install main stand without switch for electric side support.

- Remove transmission together with the complete rear wheel drive and rear wheel.

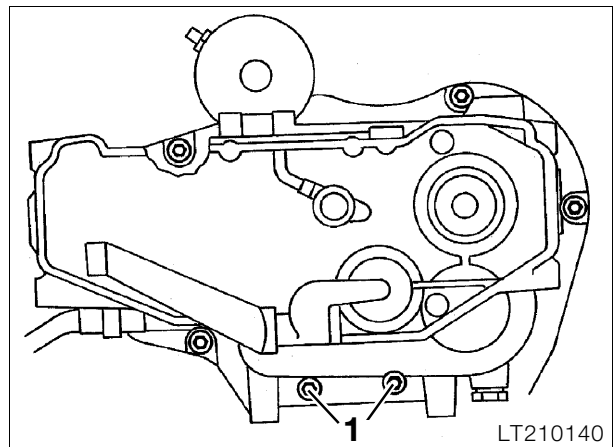

Note:

Keep transmission at installation height until the clutch control rod can be seen completely, since it can be easily bent.



Note:

To remove the ABS unit, see also Group 34, "Removing ABS unit".



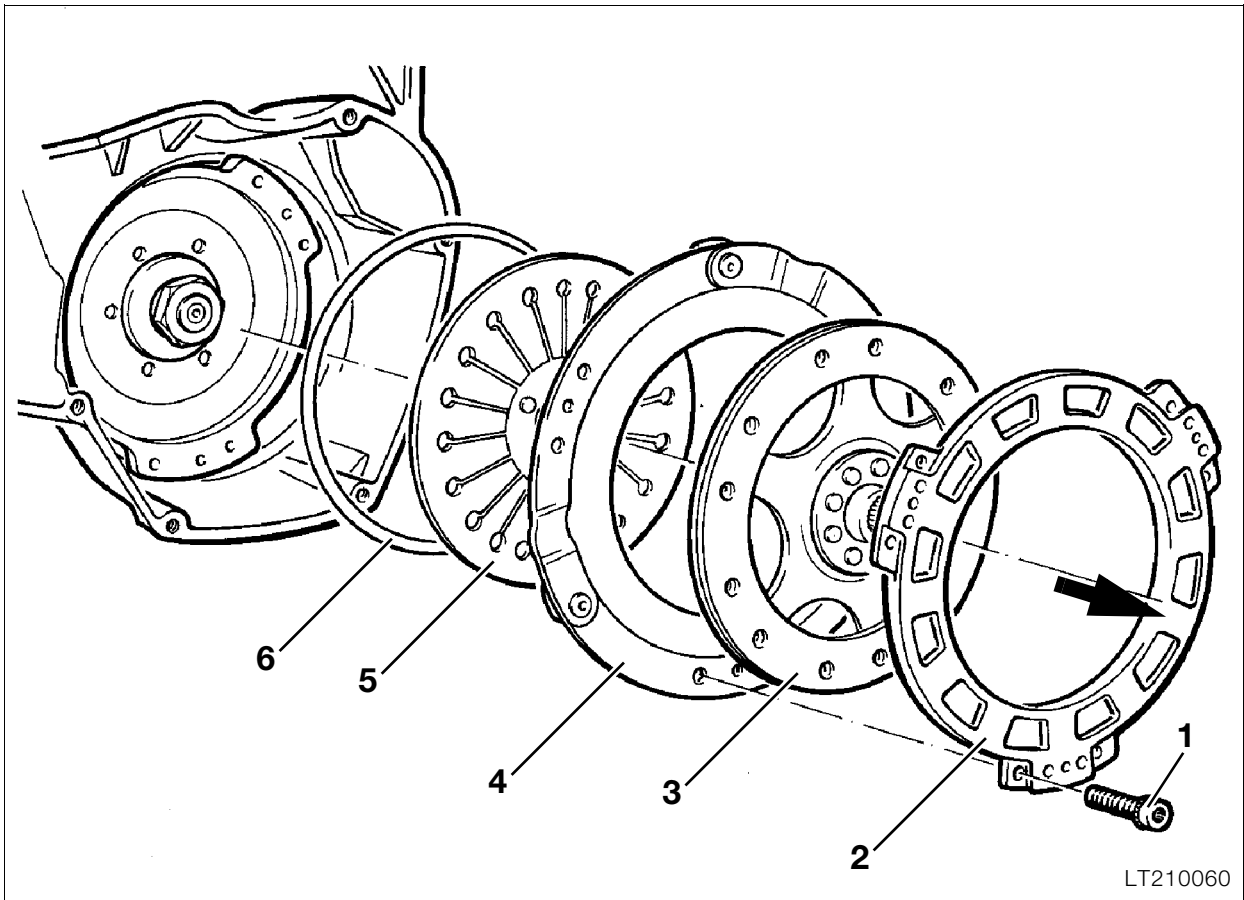

- Release housing cover (2).
- Remove clutch disc (3), pressure plate (4), diaphragm ring (5) and wire ring (6).



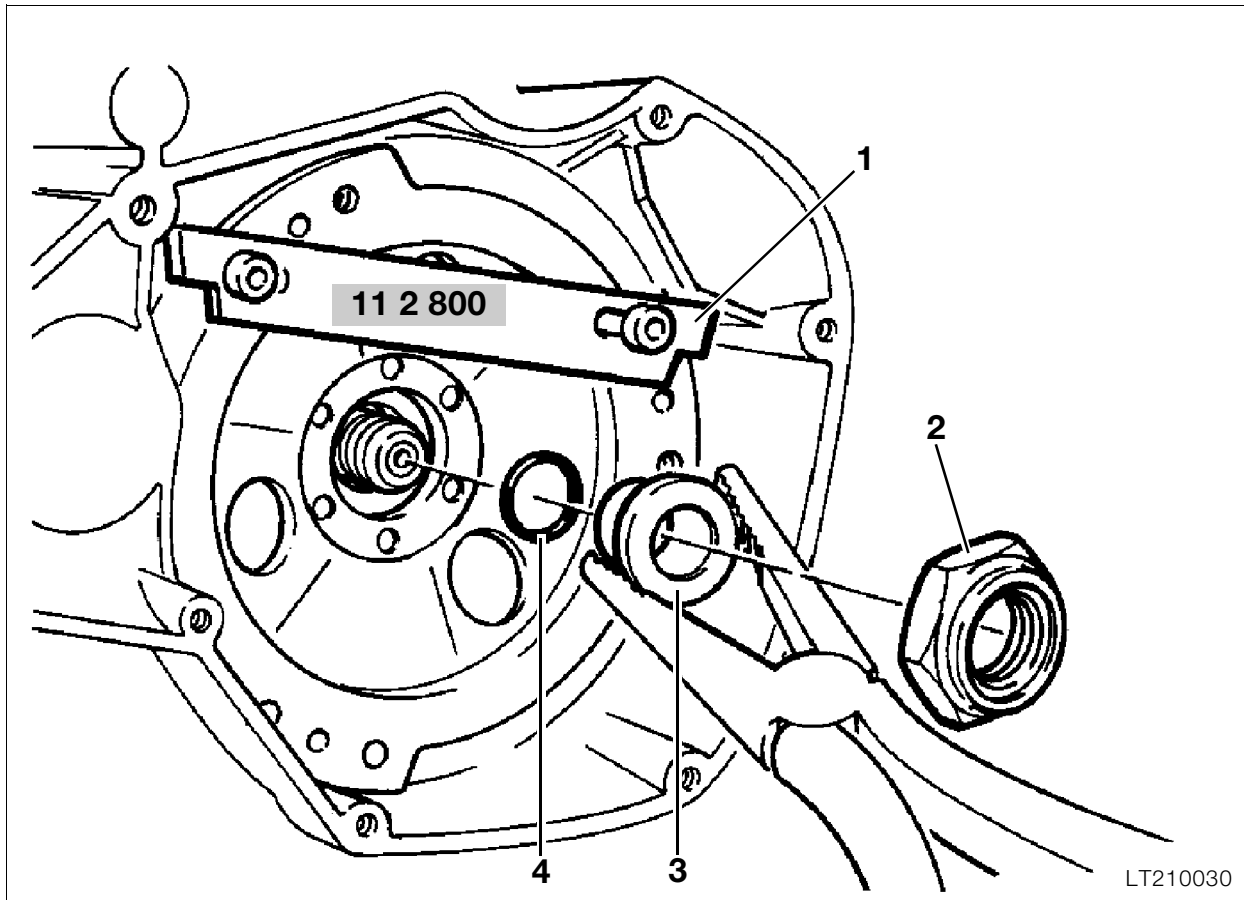

Removing clutch housing

- Secure retaining fixture (1), **BMW No. 11 2 800**, as shown.
- Release hexagon nut (2).
- Remove thrust ring (3) with pliers.
- Move clutch housing to and fro until O-ring (4) is visible.
- Cut through O-ring.

Caution:

If clutch housing is difficult to move, use three-point puller, **BMW No. 33 1 830**, and pressure tool. Do not damage bushing for thrust bearing!

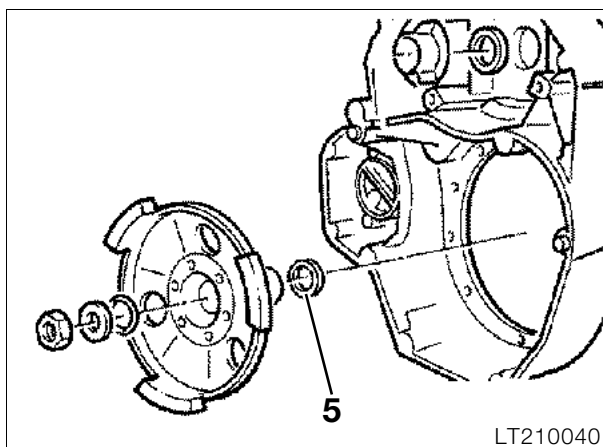

- Pull off clutch housing.



Note:
Do not lose thrust washer (5).



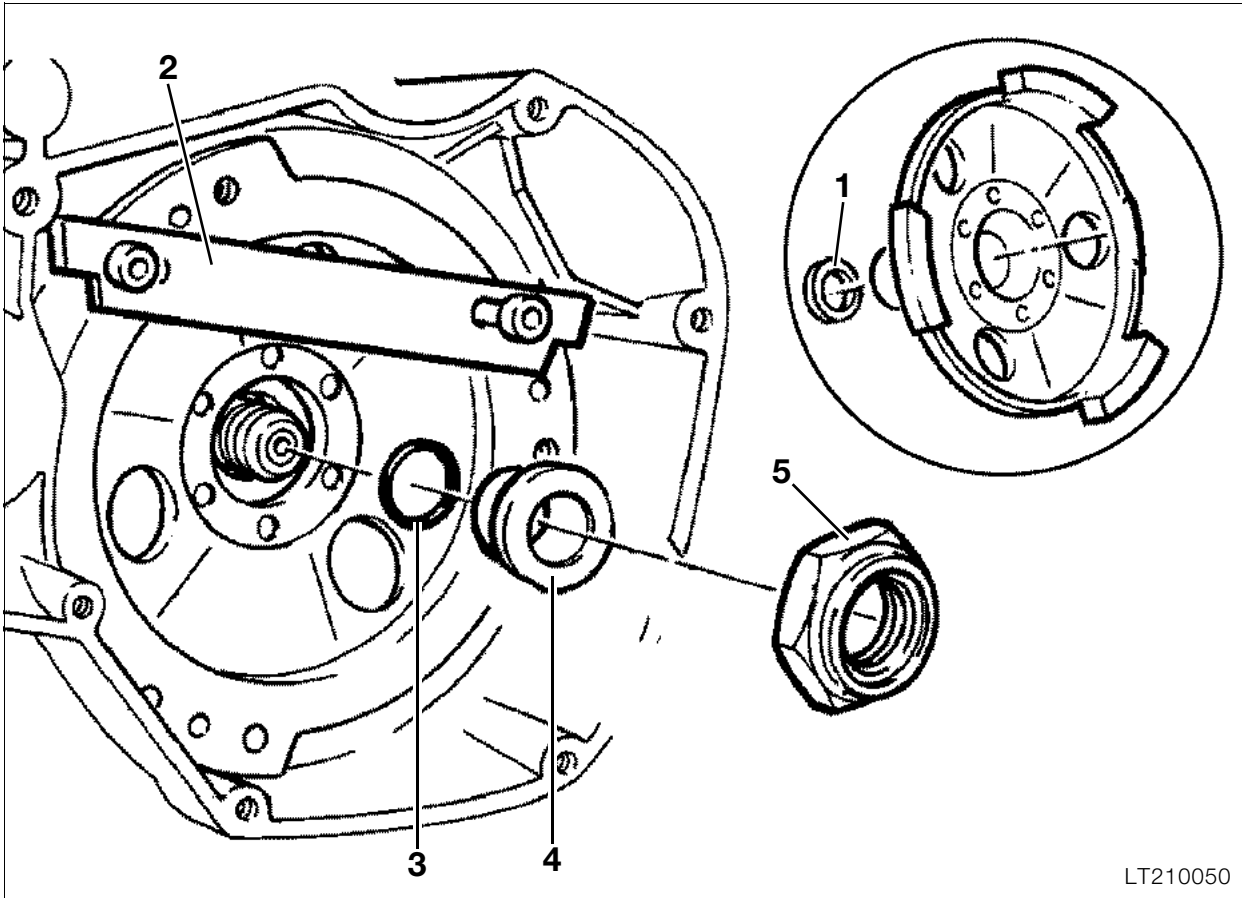

LT210050

Installing clutch housing

- Coat tapers in clutch housing with **Optimoly MP 3** or similar.
- Fit thrust washer (1) on the clutch housing.
- Using retaining device, fit clutch housing in the correct position.
- Install thrust ring (4) with new O-ring (3).
- Screw on hexagon nut (5).



Caution:

The hexagon nut must be renewed every time it is removed.



Tightening torques:

1. Tighten hexagon nut 140 Nm
2. Loosen hexagon nut again
3. Tighten hexagon nut 50 Nm
4. Tightening angle 50 °

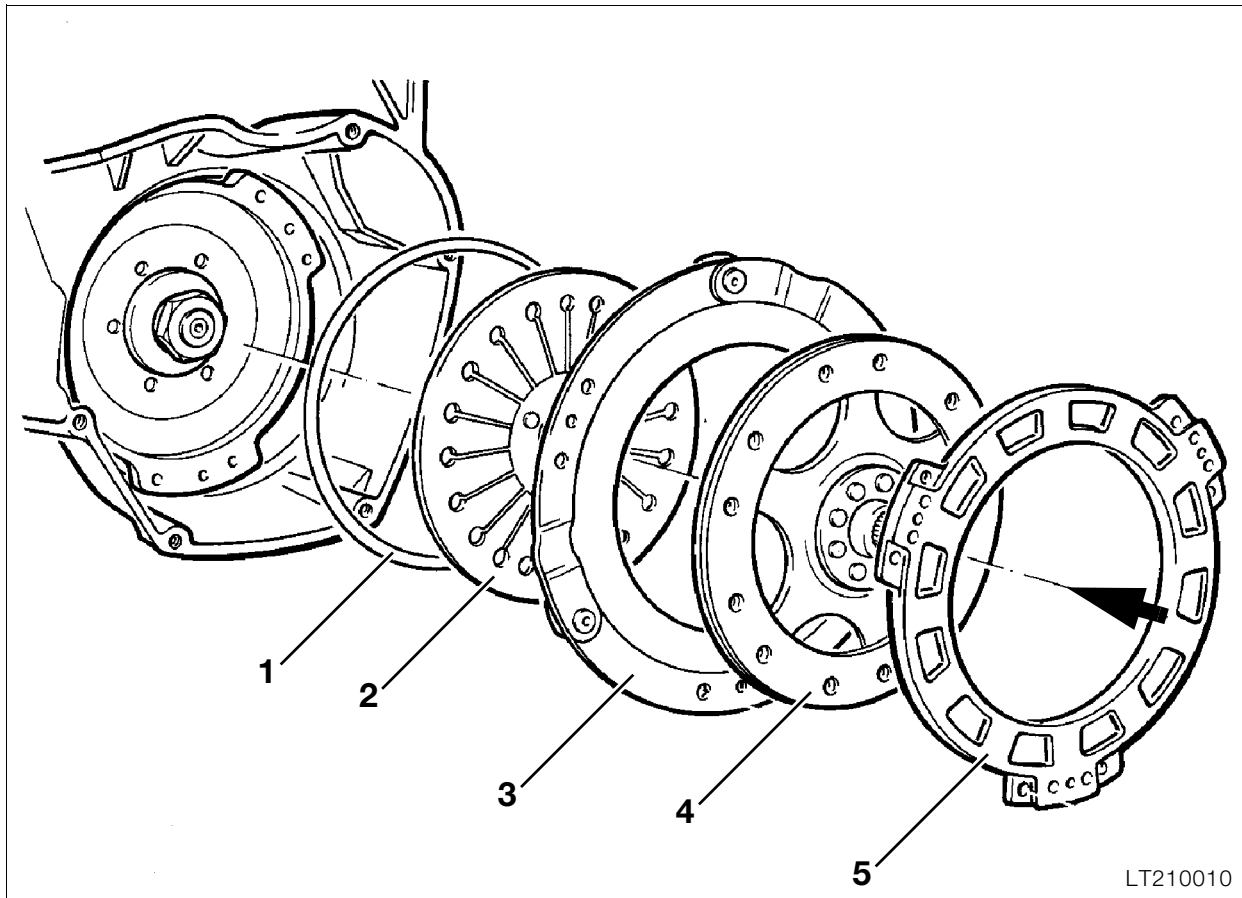

LT210010

Installing clutch

- Grease all lubrication points with **Optimoly MP 3**.

Lubrication points:

Contact surfaces of pressure plate/diaphragm spring, wire ring, cone/tip of control rod.



Note:

Install diaphragm spring (2) with the convex curve facing towards the pressure plate (3).

- Fit wire ring (1), and diaphragm spring (2) in clutch housing.
- Fit pressure plate (3), driving disc (4) and housing cover (5) in clutch housing.



Caution:

Coloured marks on the clutch housing, pressure plate and housing cover must be offset by 120°.



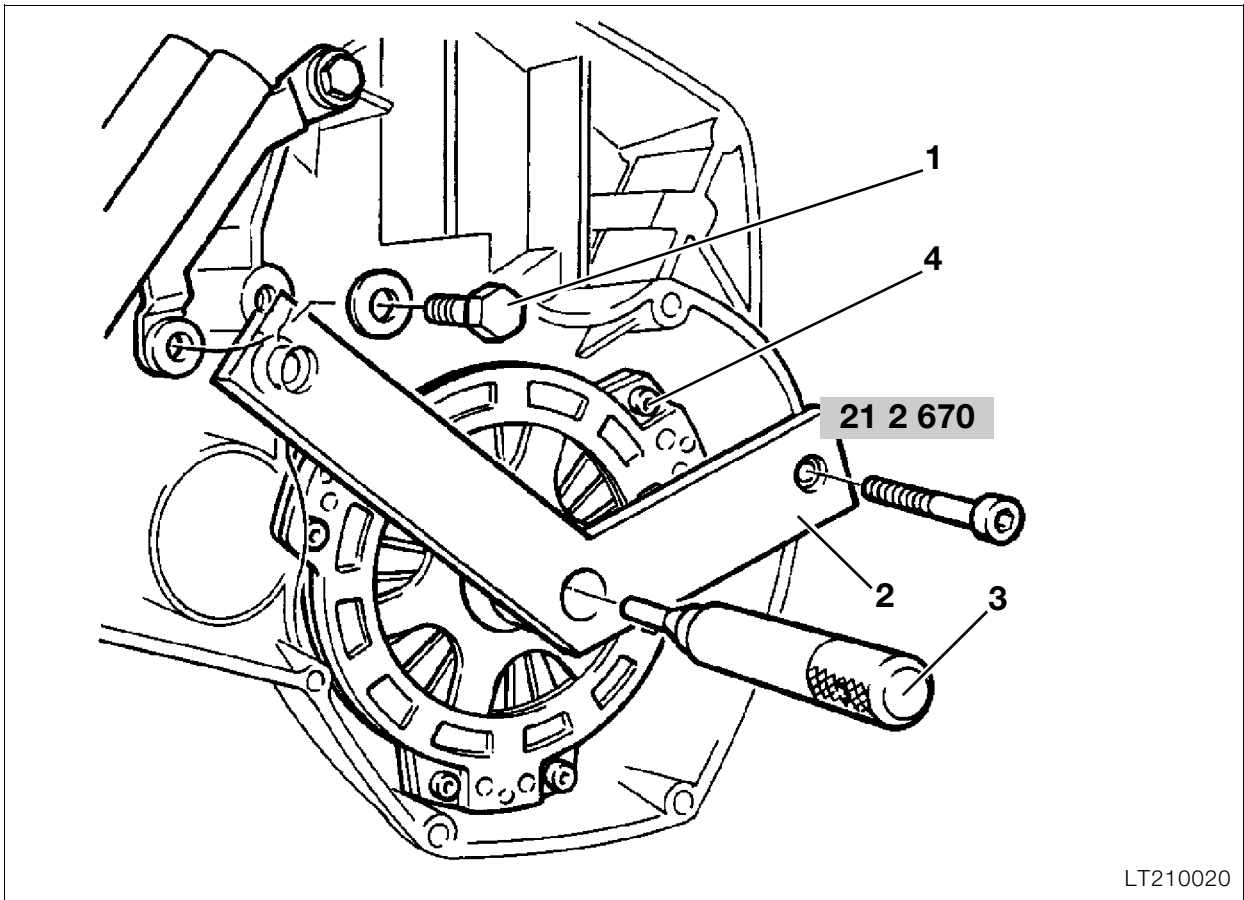

- Release lower retaining bolt (1) of the ignition coil mounting.
- Secure centring fixture (2), **BMW No. 21 2 670**, to intermediate flange.
- Centre driving disc with corresponding centring pin (3).
- Evenly tighten retaining bolts (4) crosswise.
- Remove centring fixture.



Tightening torque:
 Housing cover 19 Nm

- Screw guide pin, **BMW No. 23 1 820**, in fitted sleeve of intermediate flange.

Note:
 Install the short guide pin on the left-hand side.

- Install complete drive train.

Adjusting clutch clearance

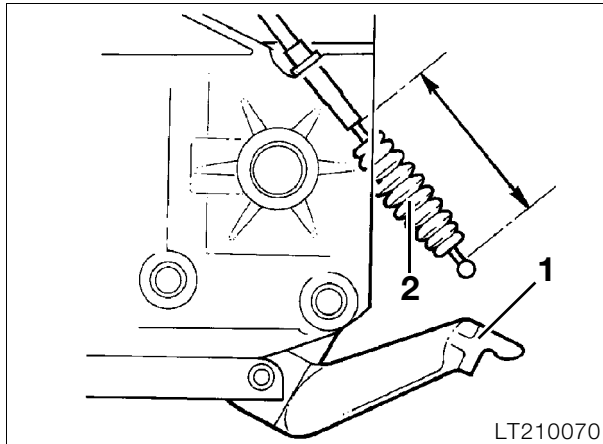

- Detach clutch cable at the clutch release lever (1).
- Slightly pull back rubber gaiter (2).
- With the aid of setting gauge, **BMW No. 21 3 500**, set dimension "B" with adjusting screw at clutch hand lever.

Dimension "B" ... 75 ± 1 mm (2.95275 ± 0.03937 in)

- Re-attach clutch cable at clutch release lever.

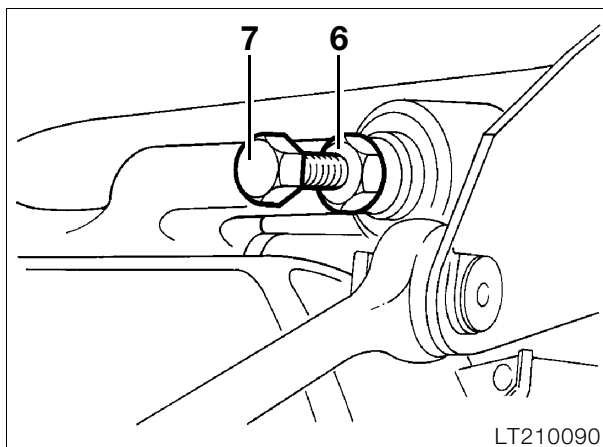

- With the aid of box wrench, **BMW No. 21 3 610**, release locknut (6) of adjusting screw (7) on clutch release lever.
- Unscrew adjusting screw by one to two turns, then screw in until pressure point can be felt.
- Lock adjusting screw with locknut.

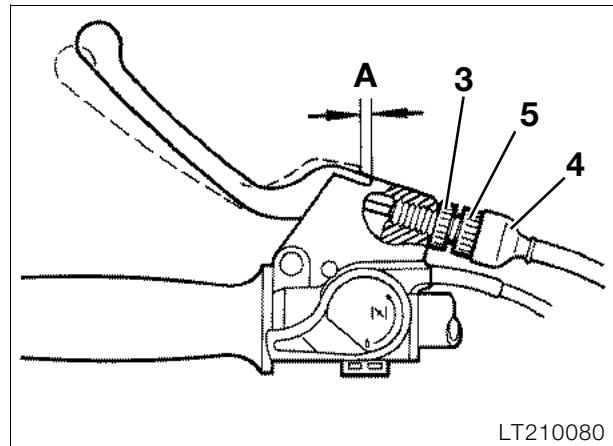

- Set dimension "A" with adjusting screw at clutch hand lever.
- Lock adjusting screw (5) with knurled nut (3).

Dimension "A" $4 \pm 0,5$ mm (1.5748 ± 0.19685 in)



Caution:

Take up subsequent wear only at the adjusting screw on the clutch release lever.



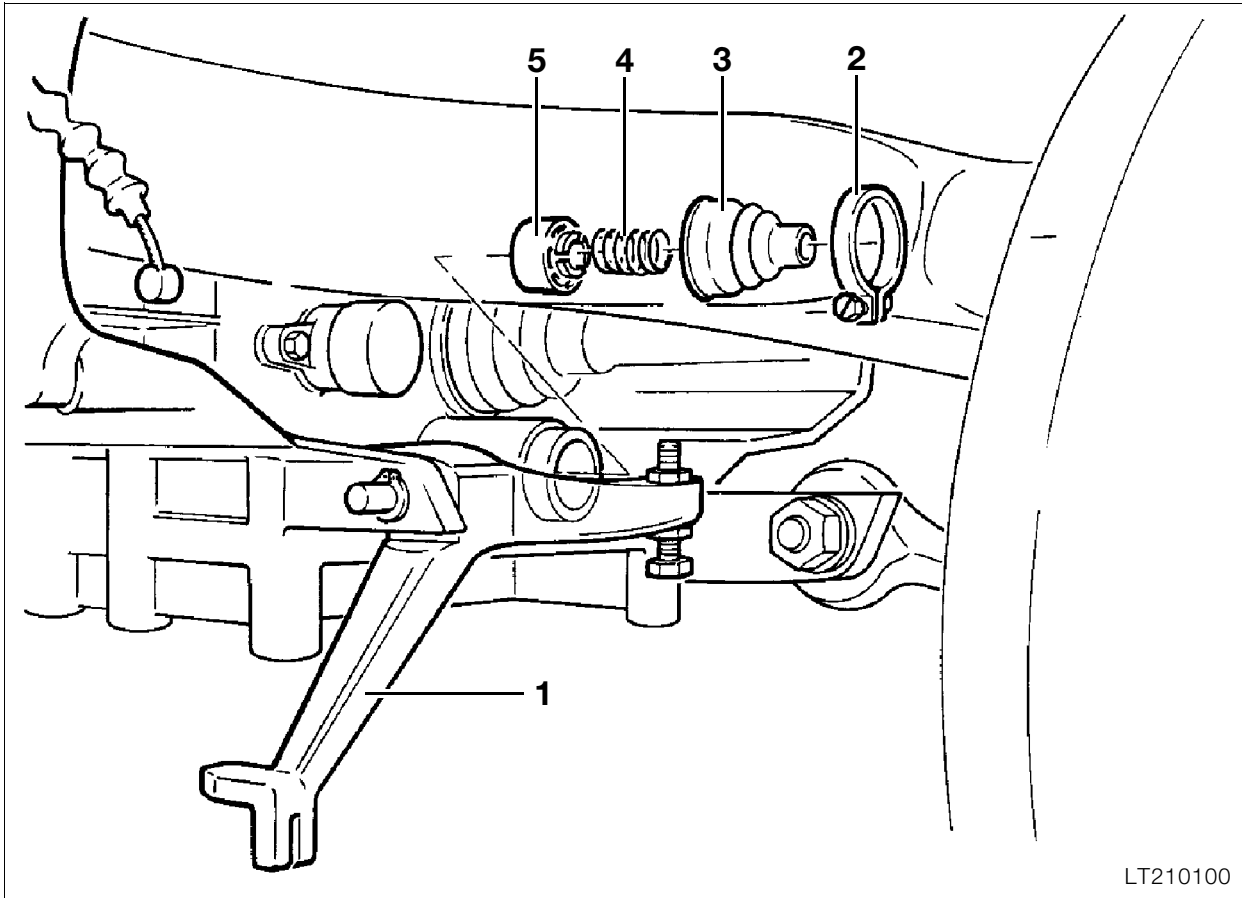

LT210100

Removing and installing clutch thrust bearing

- Remove rear wheel.
- Remove exhaust system.
- Detach clutch cable at clutch release lever (1).
- Loosen retaining clip (2) at sealing gaiter.
- Remove gaiter (3) with spring (4).
- Remove thrust bearing (5) with pointed-nose pliers.
- Install in the reverse order of removal.



⚠ Caution:

ABS rear wheel:
Check and, if necessary, adjust the sensor clearance after installing the brake caliper.

Sensor distance:

Maximum distance0.60...0.65 mm
.....(0.2362...0.2555in)

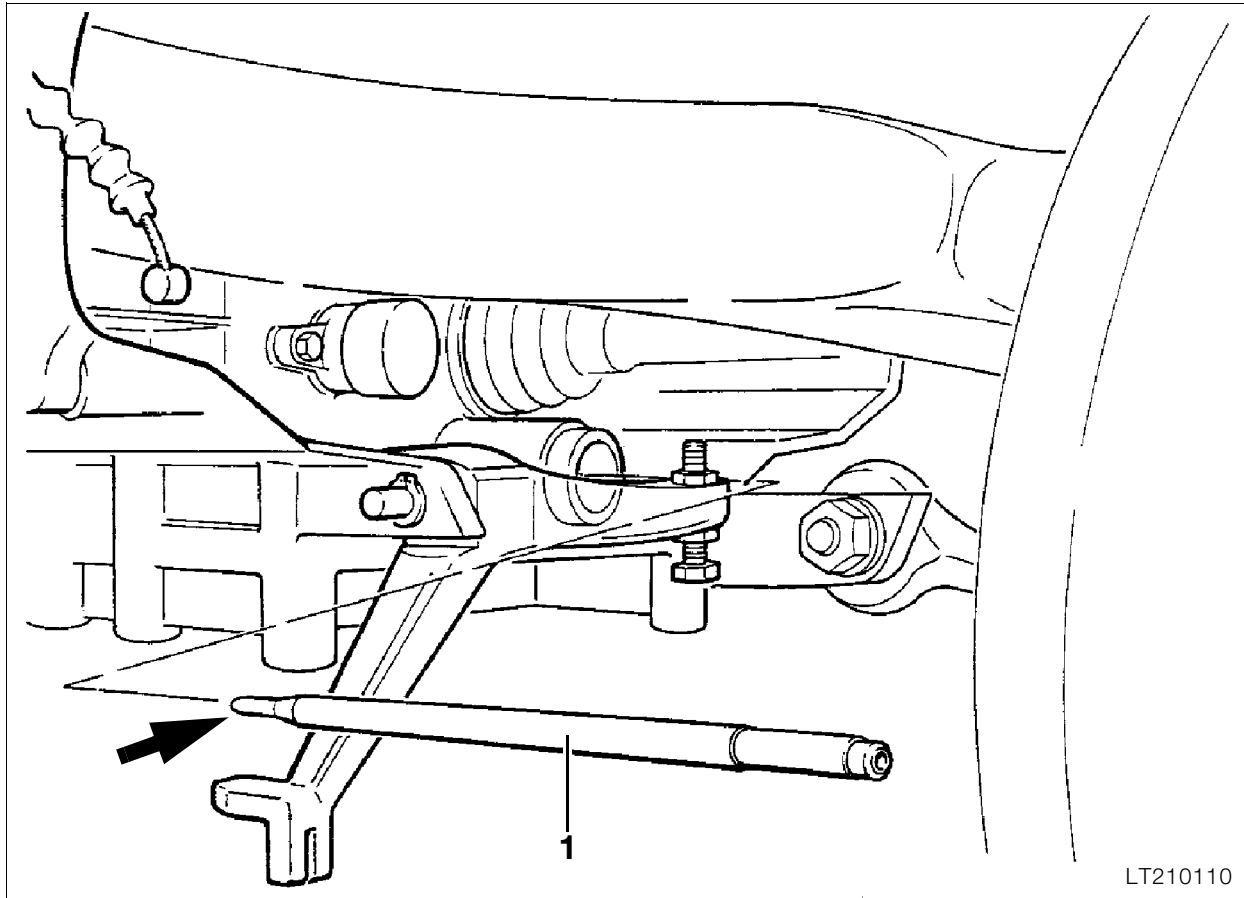

Removing and installing clutch control rod

- Remove rear wheel.
- Remove exhaust system.
- Remove clutch thrust bearing.
- Remove clutch control rod (1) by pulling to the rear.
- Install in the reverse order of removal.

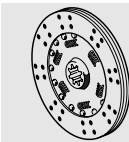

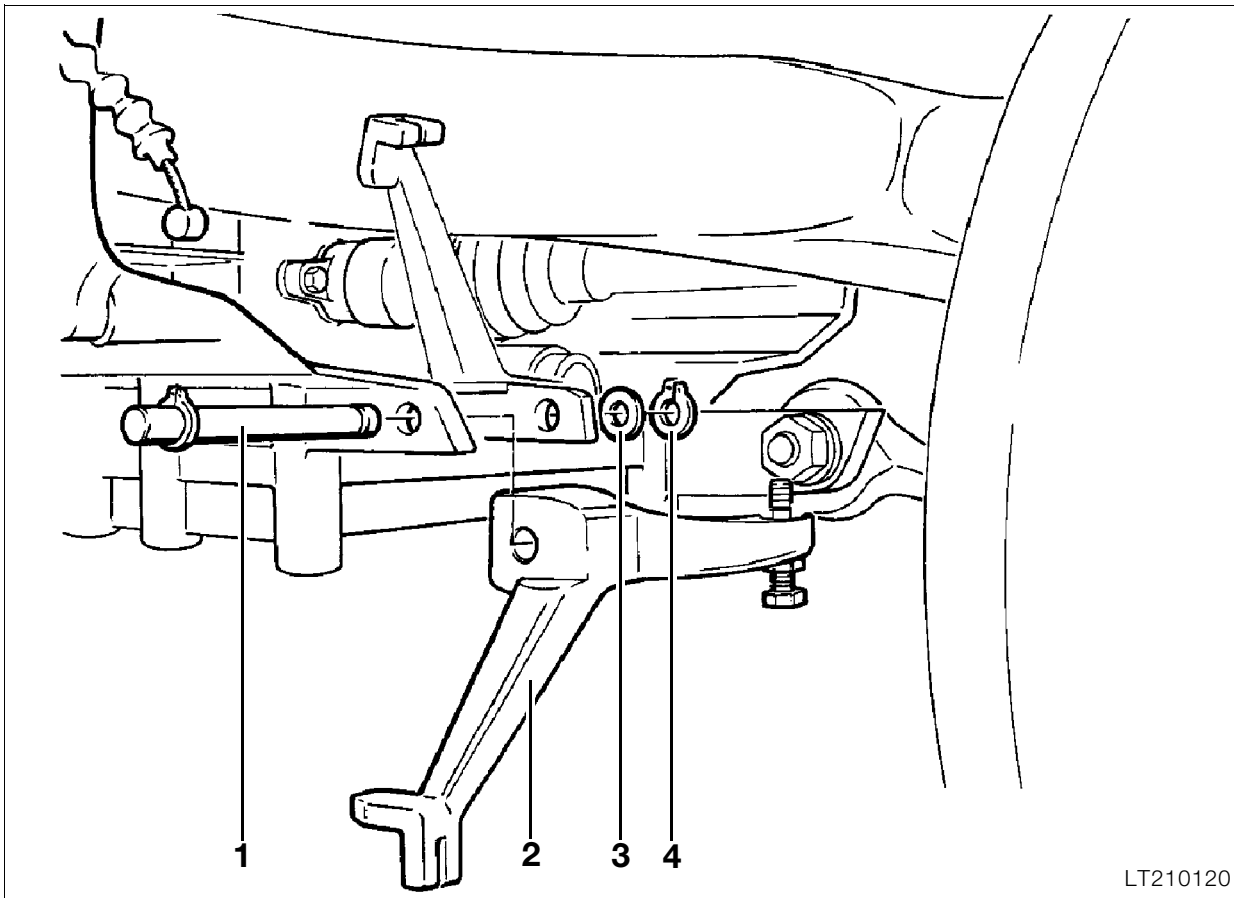

LT210120

Removing and installing clutch release lever

- Remove exhaust system.
- Detach clutch cable at clutch release lever.
- Remove retaining ring (4) and washer (3) on right-hand side.
- Remove mounting pin (1) by pulling out to left.
- Remove clutch release lever (2).
- Install in the reverse order of removal.



Note:

Check clutch clearance and adjust if necessary.



Tightening torques:

Exhaust to cylinder head.....	21 Nm
Exhaust holder to footrest plate.....	33 Nm
Exhaust retaining bracket to gearbox	41 Nm
Front silencer	12 Nm

Troubleshooting

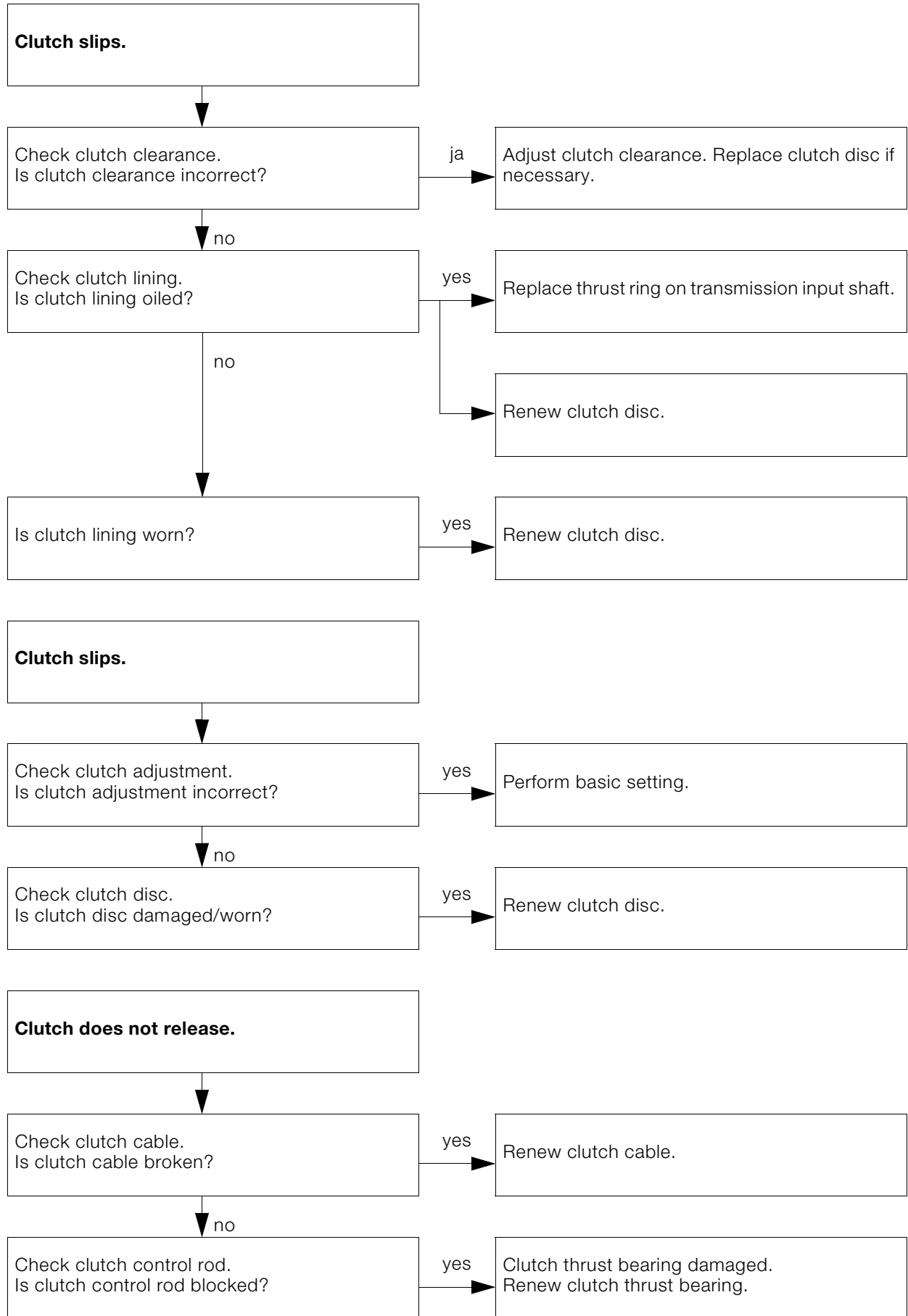

**Clutch operation difficult.
Clutch too harsh?**



Check output shaft lubrication.
Is output shaft not lubricated?

yes



Lubricate with Optimoly MP 3.



23 Gearbox

Contents

Page

Technical Data	3
Removing transmission (gearbox)	5
Preparatory work	5
Removing starter	6
Removing bearing mount with main stand	7
Removing transmission (gearbox)	8
Disassembling transmission (gearbox)	9
Removing transmission cover.	9
Disassembling/assembling transmission cover	10
Removing and installing bearing shell	10
Removing and installing shaft sealing ring on input shaft	10
Removing and installing locking lever	10
Removing gear selector drum	11
Removing gearshift forks	11
Removing transmission shafts	12
Removing pawl	12
Removing selector shaft	13
Removing segment	13
Removing and installing shaft sealing ring on input shaft	13
Removing and installing shaft sealing ring for gear selector drum	14
Removing and installing bearing shell for taper roller bearing on input shaft	14
Removing and installing ball bearing on intermediate shaft	14
Disassembling and assembling input shaft	15
Disassembling input shaft	15
Assembling input shaft	15

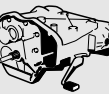

Contents

Page

Disassembling and assembling output shaft	17
Removing ball bearing	17
Removing spur gears	18
Installing spur gears	19
Installing transmission shafts	20
Installing gearshift forks	20
Measuring distances between transmission shafts	21
Measuring bearing distance of shafts	21
Measuring transmission cover	22
Installing transmission cover	24
Installing transmission (gearbox)	25
Installing bearing mount with main stand	26
Installing starter	27
Re-assembling motorcycle	28

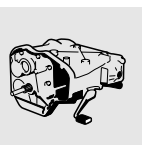

Technical Data	K 1100 LT	K 1100 RS
Type of gearshift	5-speed transmission with dog-clutch engagement and integrated damper for all gears	
Type of gearshift	With adjustable gearshift pedal and gear selector drum with overshoot protection	
Transmission ratio 1st gear 2nd gear 3rd gear 4th gear 5th gear	4.50 2.96 2.30 1.88 1.61	
Oil grade above 5° C below 5° C all year round	Brand-name hypoid gear oil, API class GL 5 SAE 90 SAE 80 SAE 80 W 90	
Capacity	l (Imp.pt)	0.8 (1.408)
Axial clearance, intermediate shaft	mm (in)	0.05 ...0.15 (0.0019685...0.0059055)
Axial clearance, output shaft	mm (in)	0.05 ...0.15 (0.0019685...0.0059055)
Preload, input shaft	Preloadmm (in) = Coefficient friction Nm 0.03 (0.00118) = 0.19 ± 0.02 0.055 (0.00217)= 0.34 ± 0.02 0.08 (0.00315) = 10.50 ± 0.02	

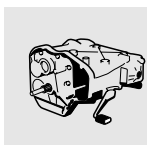

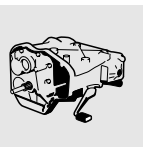

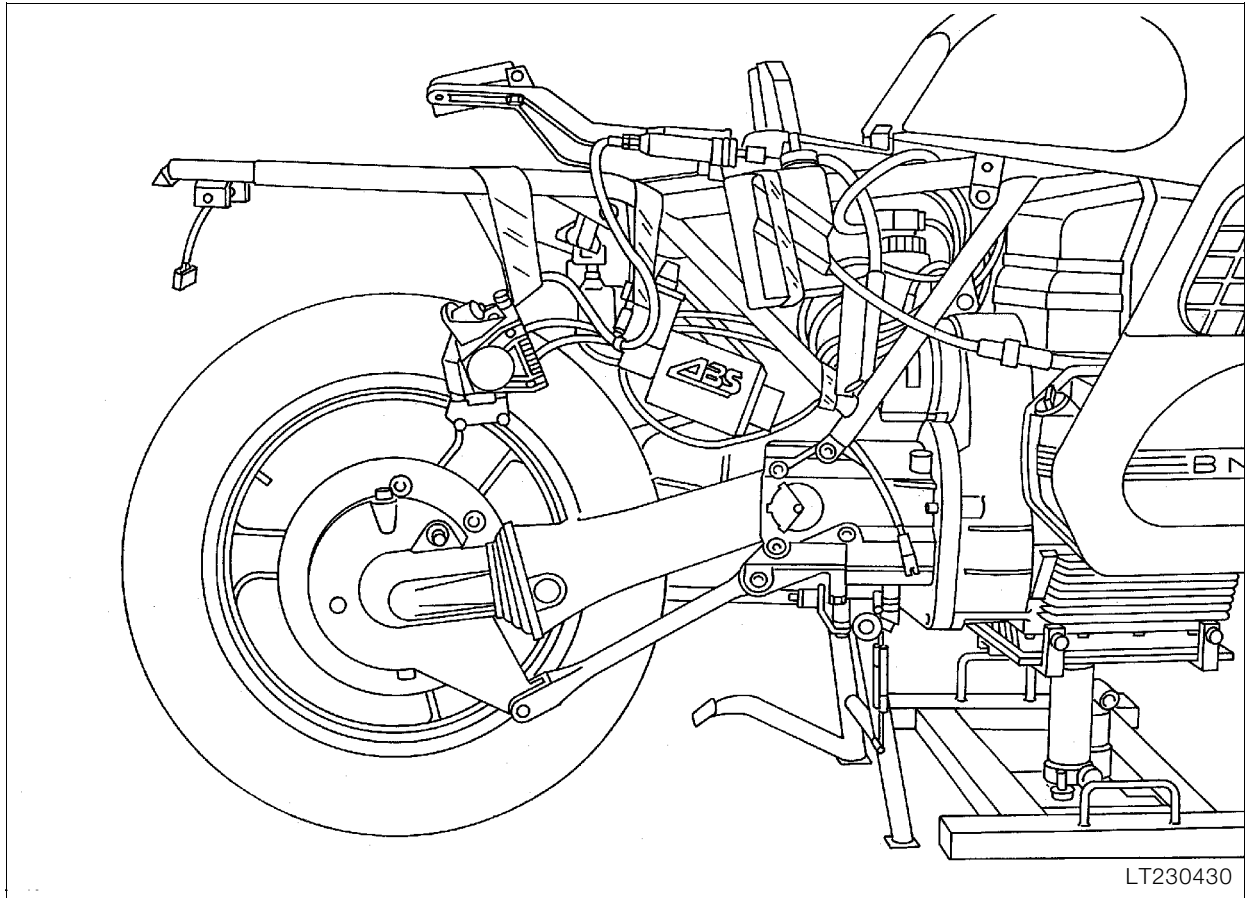

Removing transmission (gearbox)

Preparatory work

- **[RS]** Remove left fairing side section .
- Remove exhaust system.
- Disconnect CAT plug connection for oxygen sensor.
- Remove left and right footrest plate.
- Remove rear mudguard.
- Remove rear brake caliper.
- Remove rear wheel.
- Remove suspension strut.
- Remove rear wheel drive.
- Remove swinging arm.
- Remove rear cover panel with coolant level equalising tank.
- Remove Motronic control unit.
- Remove battery.
- **[ABS I]** Remove control unit.
- **[ABS I]** Detach pressure modulators from holder and secure to rear section of frame.

- **[ABS I]** Remove holder for pressure modulators.
- **[ABS II]** Remove ABS unit.
- Remove battery carrier.
- Remove starter motor.



Note:

Secure brake caliper, pressure modulators, reservoir and, footrest plate with adhesive tape to frame.



Note:

For removal of ABS unit see Group 34, "Removing ABS unit".

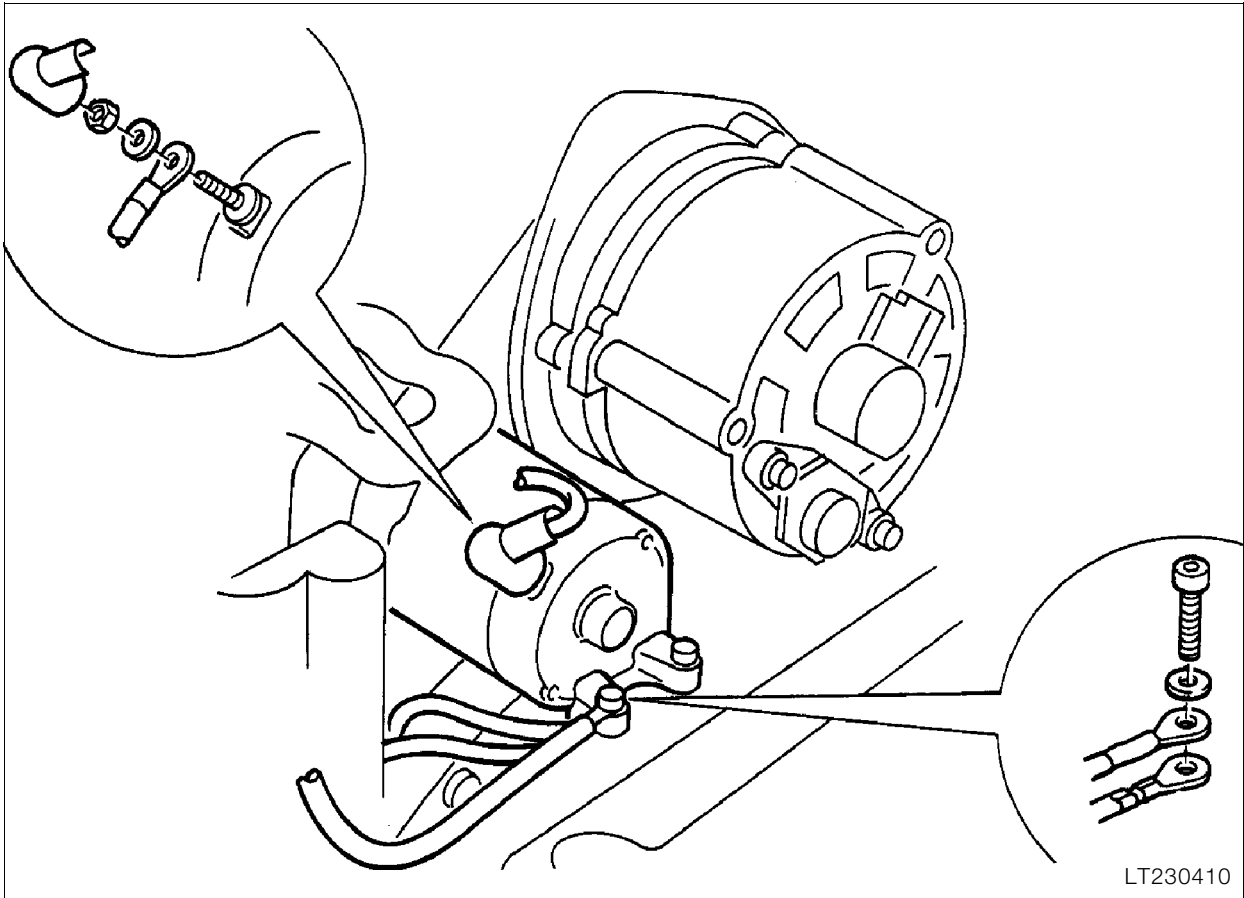

Removing starter

- Release positive and negative lead at starter.
- Release mounting.
- Pull out starter.

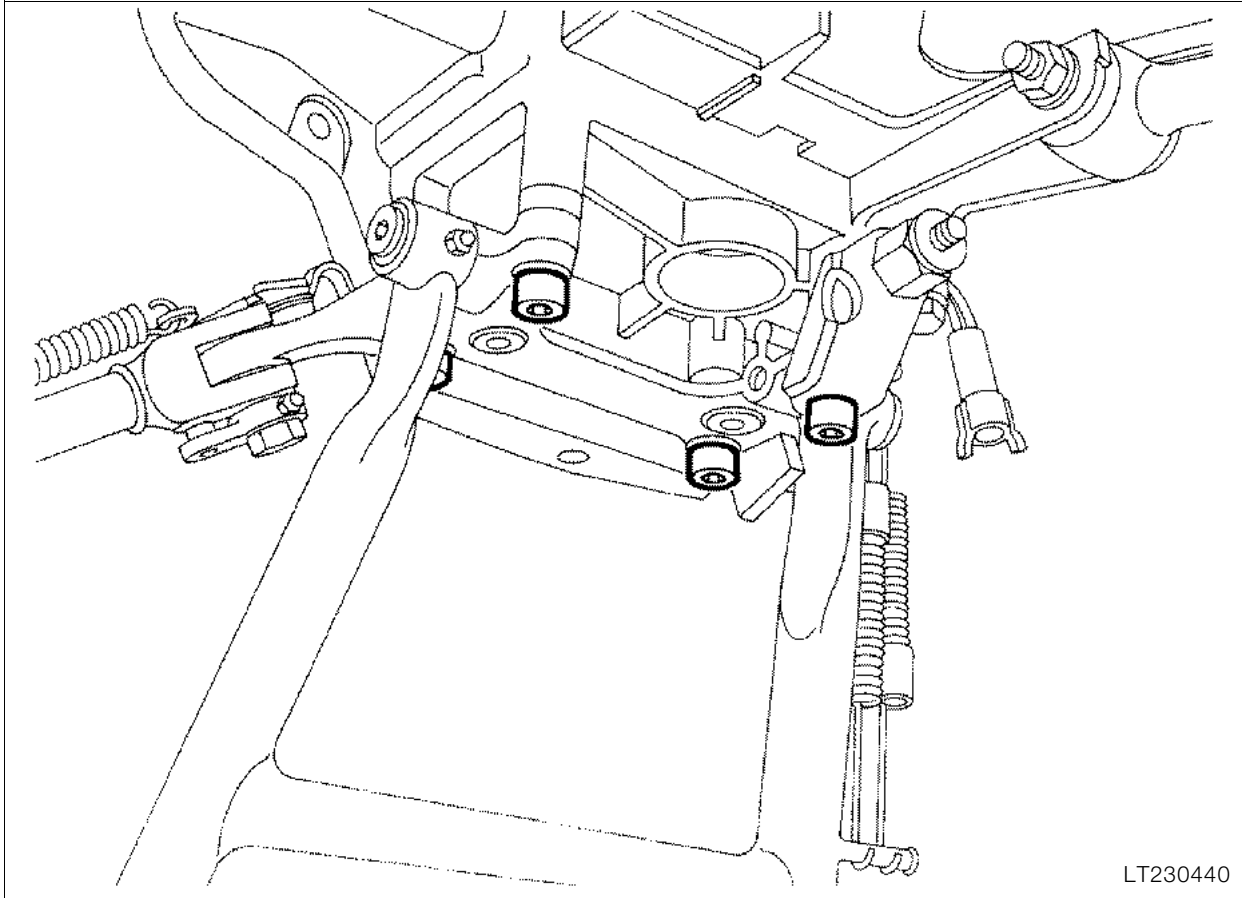

LT230440

Removing bearing mount with main stand

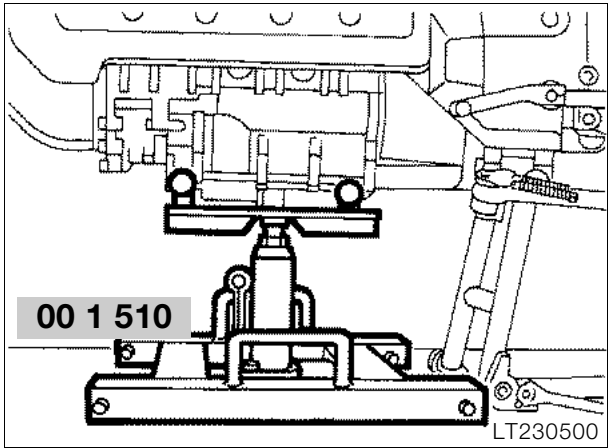

00 1 510

LT230500

- Secure lifting gear, **BMW No. 00 1 510**, to the oil sump and slightly raise engine.
- Release mounting for main stand.

⚠ Caution:

The retaining bolts are micro-encapsulated and can therefore not be reused.

- Cut through cable clip on main stand.

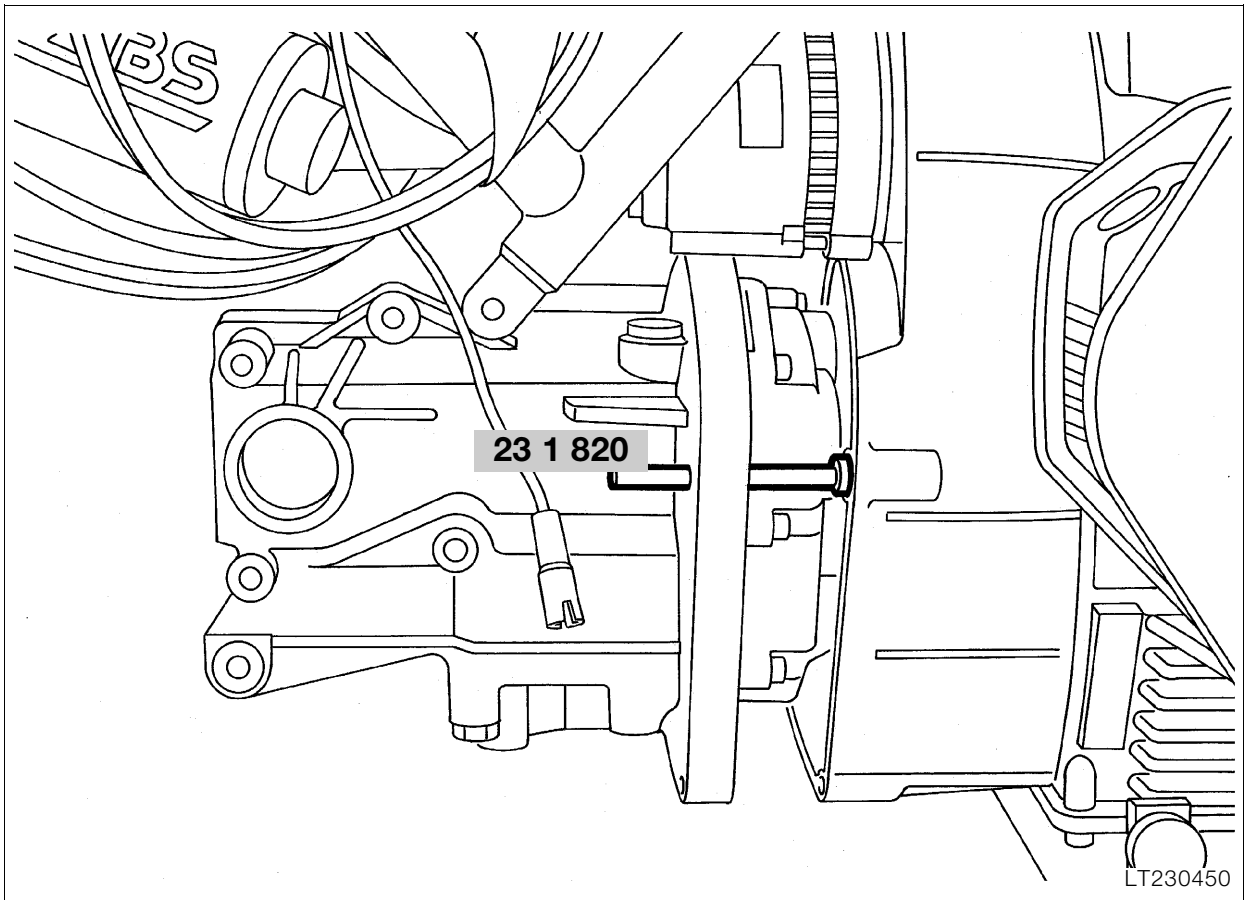

Removing transmission (gearbox)

- Release retaining bolts.
- Screw guide pins, **BMW No. 23 1 820**, in holes with fitted sleeve, long pin on right-hand side.
- Slowly pull off gearbox.



Caution:

Hold gearbox at installation height until the control rod can be seen completely, otherwise it can easily bend.

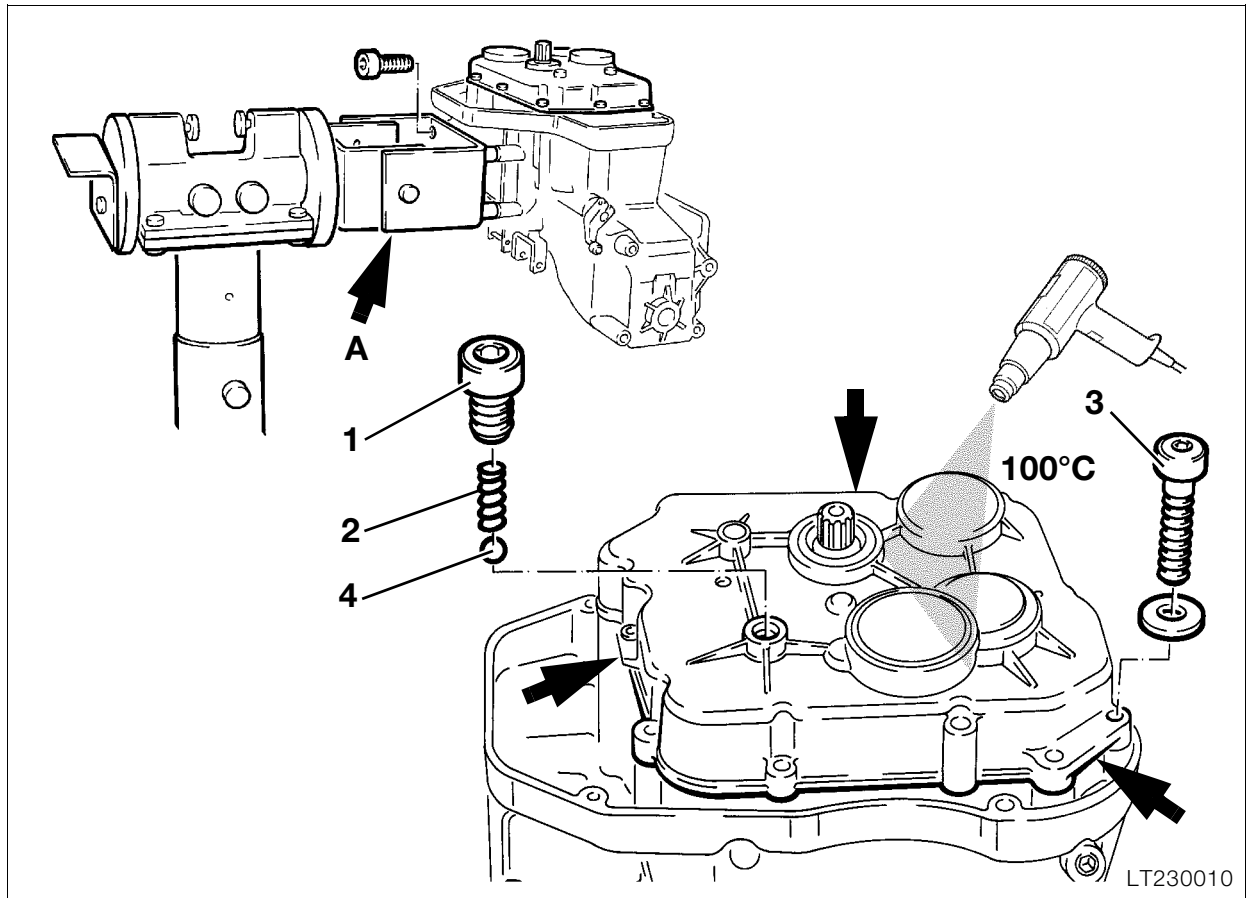

Disassembling transmission (gear-box)

Removing transmission cover.

- Secure gearbox with holder (arrow "A"), **BMW No. 23 1 600**, to assembly stand.
- Engage neutral.
- Release idle lock (1).
- Remove coil (2) and ball (4).
- Release screws (3).
- Heat bearing seat in transmission cover to 100 °C
- Evenly press off transmission cover at three points (arrows).

Disassembling/assembling transmission cover

Removing and installing bearing shell

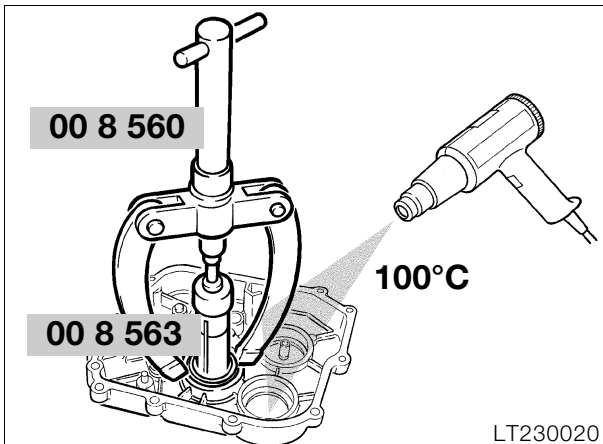

- Heat bearing cover to 100 °C.
- Remove bearing shell with Kukko support, **BMW No. 00 8 560**, and internal extractor 21/5, **BMW No. 00 8 563**.

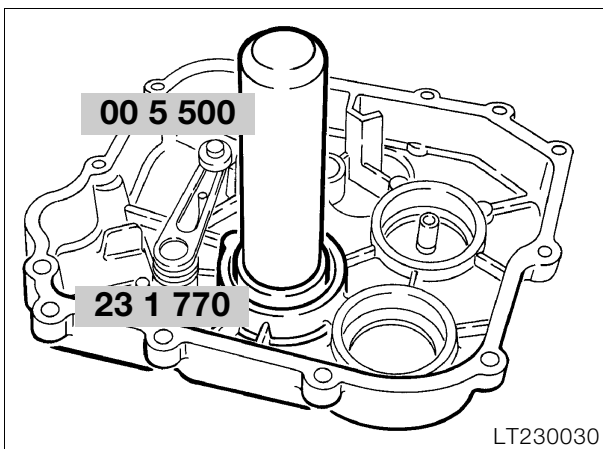

- Fit bearing shell in transmission cover while still hot.
- Drive bearing shell onto the bottom of its seat with drift, **BMW No. 23 1 700**, and handle **BMW No. 00 5 500**.

Removing and installing shaft sealing ring on input shaft

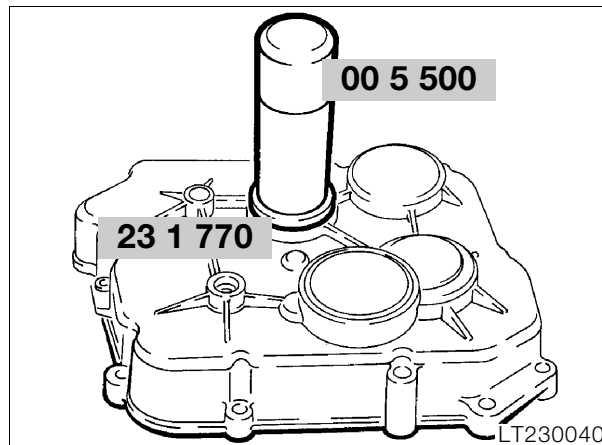

- Drive out shaft sealing ring with drift from the inside.
- Fit new sealing ring with drift, **BMW No. 23 1 770** and handle, **BMW No. 00 5 500**.



Note:

If the coefficient of friction of the input shaft is to be checked, do not fit sealing ring until measurement has been completed.

Removing and installing locking lever

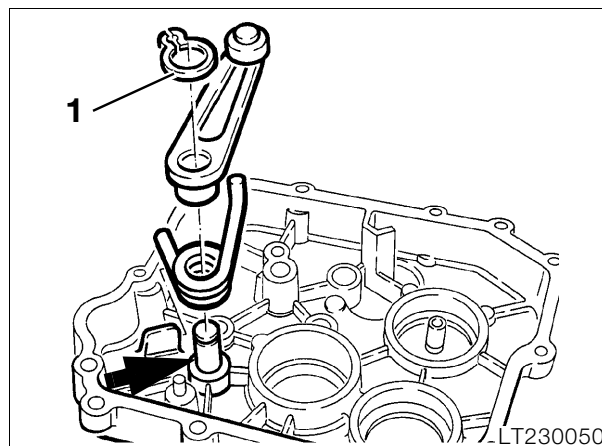

- Release retaining ring (1)
- Lift short arm of spring over contact surface (arrow).
- Remove lever and spring.
- Install in the reverse order of removal.

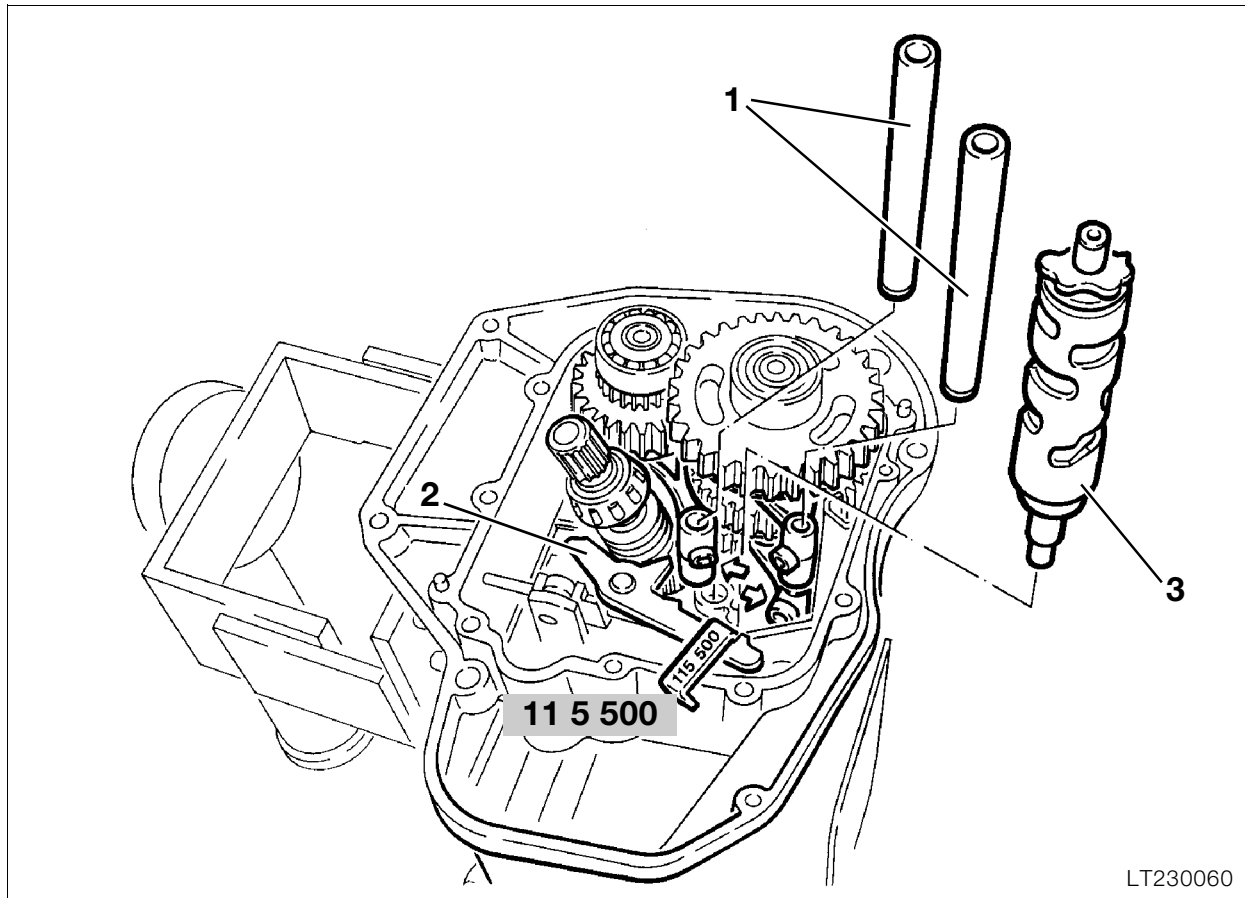

LT230060

Removing gear selector drum

- Remove shafts (1) of gearshift forks.
- Press pawl (2) towards the outside and secure with clamping fixture (arrow),
BMW No. 11 5 500.
- Tilt back input shaft by approx. 45°
- Turn gearshift forks towards the outside until guide pins are free.
- Remove gear selector drum (3).



Note:
Note sleeves on guide pins.

Removing gearshift forks

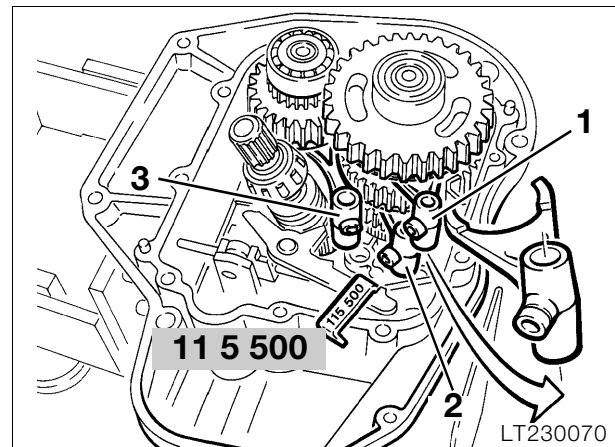

LT230070

1. Gearshift fork, 1st and 2nd gear
2. Gearshift fork, 5th gear
3. Gearshift fork, 3rd and 4th gear

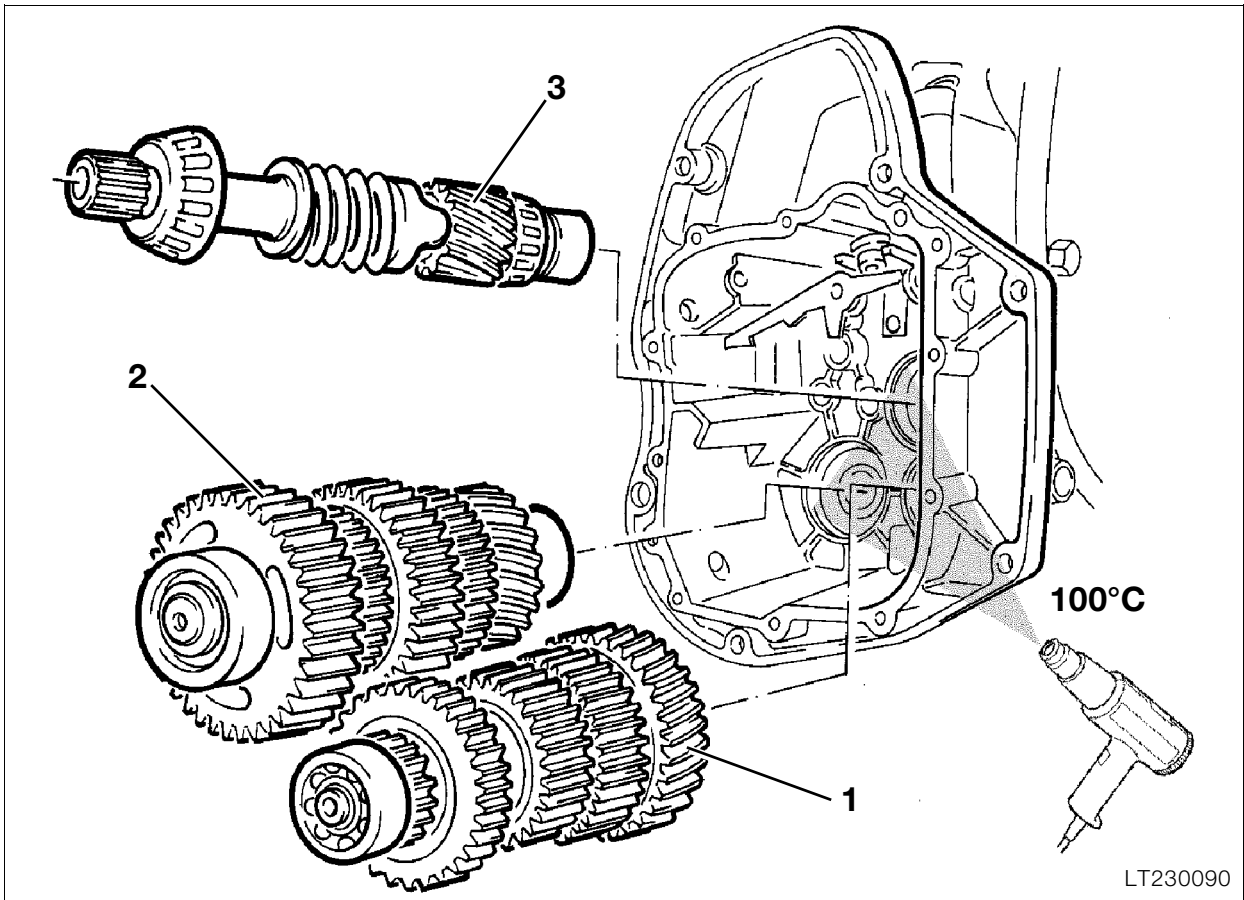

LT230090

Removing transmission shafts

- Heat bearing seat of input shaft (1) and the intermediate shaft (2) to 100 °C.
- Pull out both shafts together.
- Remove input shaft (3).

Removing pawl

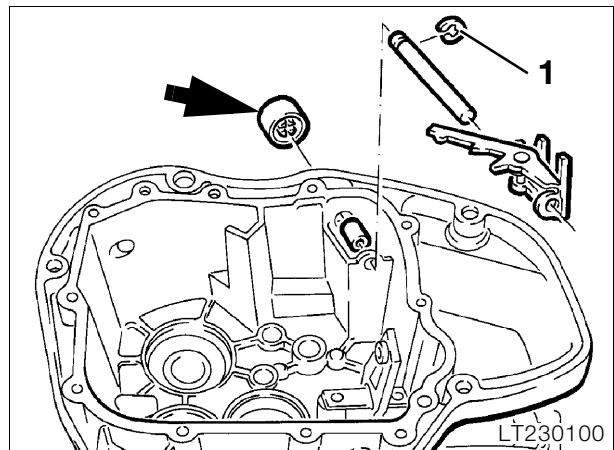

LT230100

- Using drift, drive out vent (arrow) from the inside.
- Remove retaining ring (1) on guide rod.
- Pull out guide rod.
- Remove pawl retaining bracket together with pawl.
- Remove retaining ring on pawl shaft.
- Remove pawl from pawl retaining bracket.

Removing selector shaft

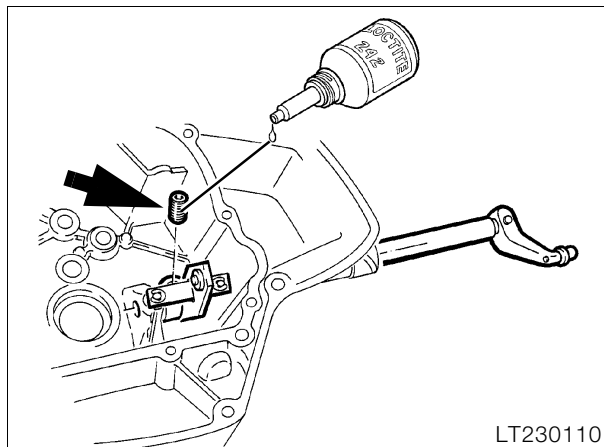

- Release setscrew (arrow) (secured with Loctite).
- Pull out selector shaft together with gearshift lever.

Removing segment

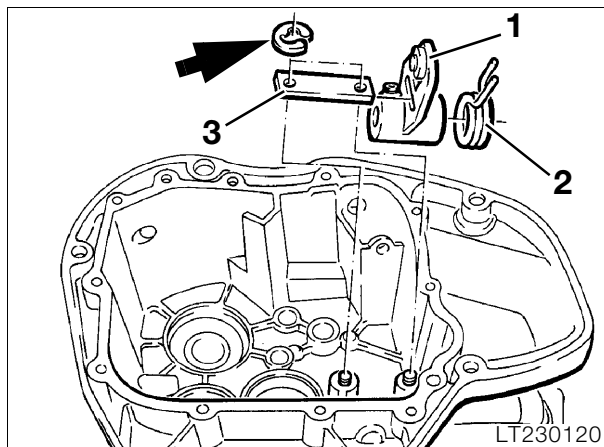

- Remove retaining ring (arrow).
- Remove segment (1) together with coil spring (2) and limit stop (3).
- Install in the reverse order of removal.



Caution:

Secure setscrew with **Loctite 242**; screw and hole must be clean and free of grease.



Tightening torque:

Setscrew, selector shaft 17 Nm

- Drive in transmission case bent by 10 mm and fit cap.

Removing and installing shaft sealing ring on input shaft

- Drive out shaft sealing ring from inside.

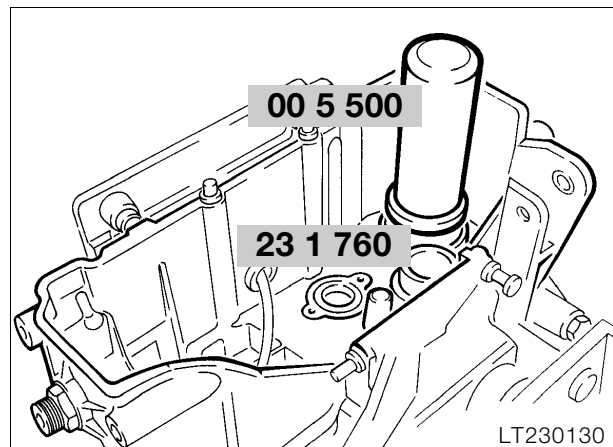

- Fit shaft sealing ring using drift, **BMW No. 23 1 760** and handle, **BMW No. 00 5 500**.

Removing and installing shaft sealing ring for gear selector drum

- Switch for gear indicator removed.
- Gear selector drum removed.

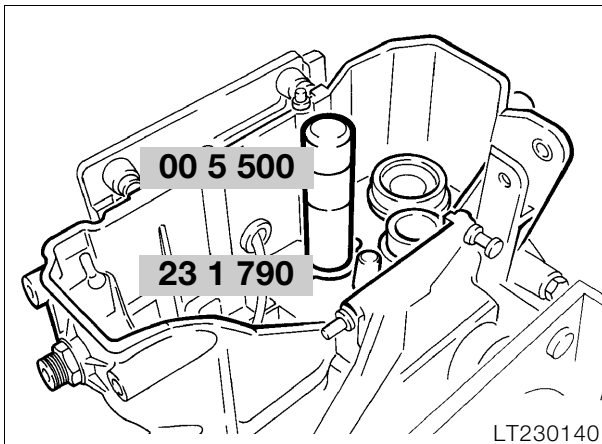

- Lever out shaft sealing ring with screwdriver.
- Fit shaft sealing ring using drift, **BMW No. 23 1 790** and handle, **BMW No. 00 5 500**.

Removing and installing bearing shell for taper roller bearing on input shaft

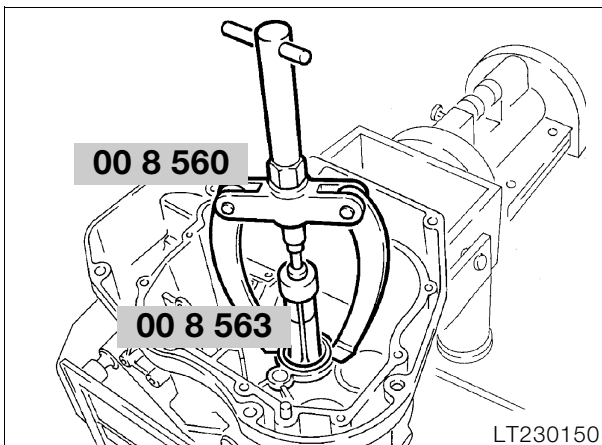

- Heat transmission housing to 100 °C.
- Remove bearing shell with the aid of support, **BMW No. 00 8 560**, and internal extractor, **BMW No. 00 8 563**.
- Fit new bearing shell in transmission housing while still hot.
- Drive bearing shell to bottom of seat with drift, **BMW No. 23 1 770**, and handle **BMW No. 00 5 500**.

Removing and installing ball bearing on intermediate shaft

- The intermediate shaft can only be replaced as a complete unit.

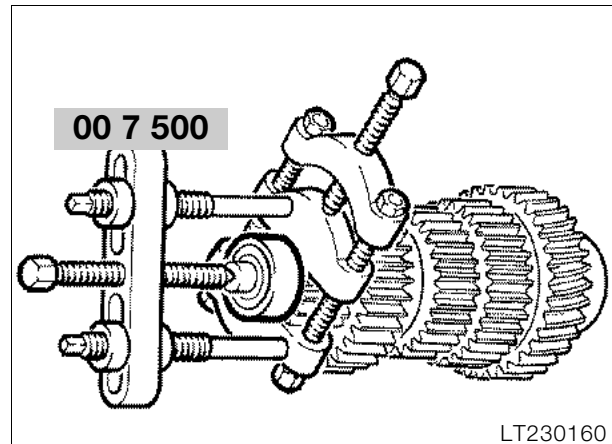

- Remove ball bearing using universal puller, **BMW No. 00 7 500**.
- To facilitate installation, heat ball bearing to 80 °C.

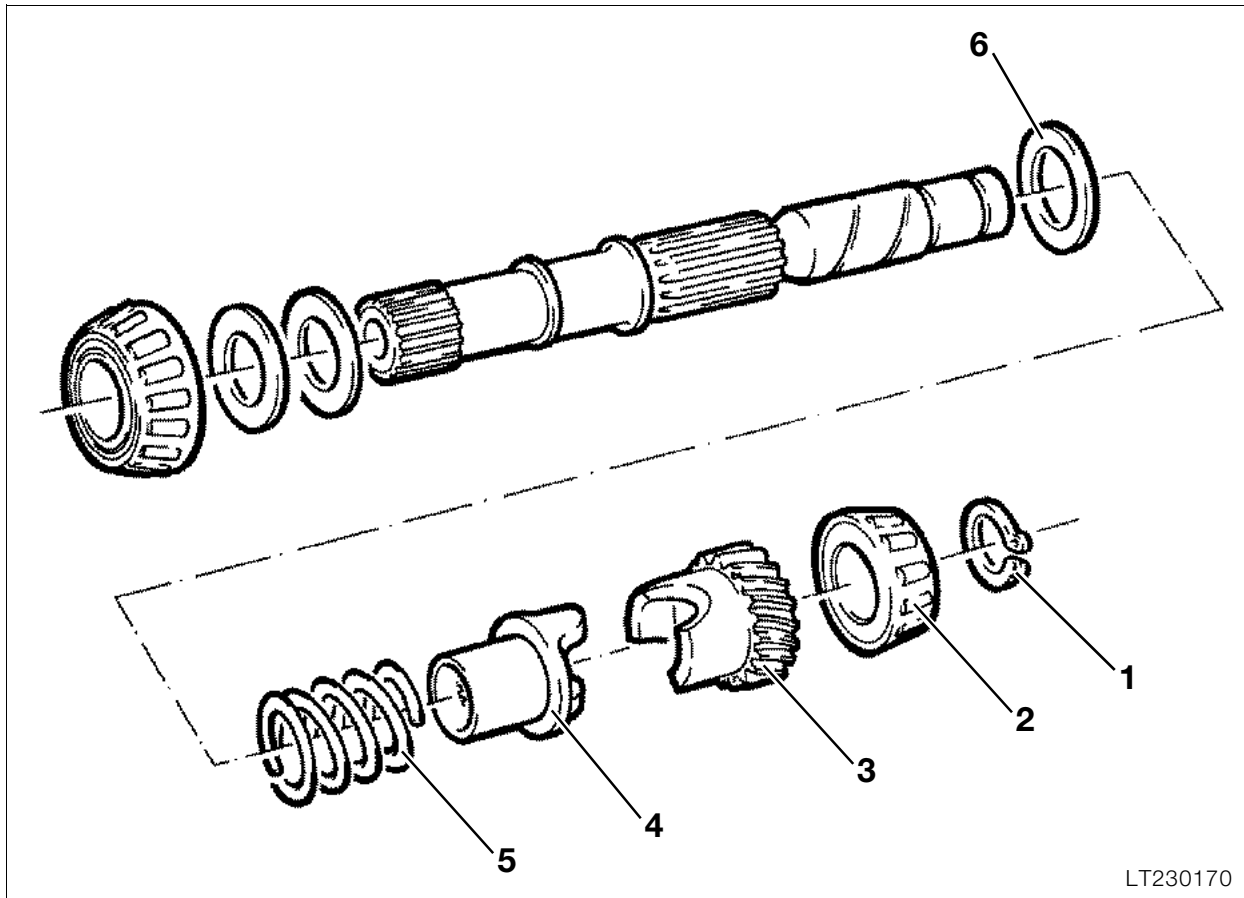

LT230170

Disassembling and assembling input shaft

Assembling input shaft

Disassembling input shaft

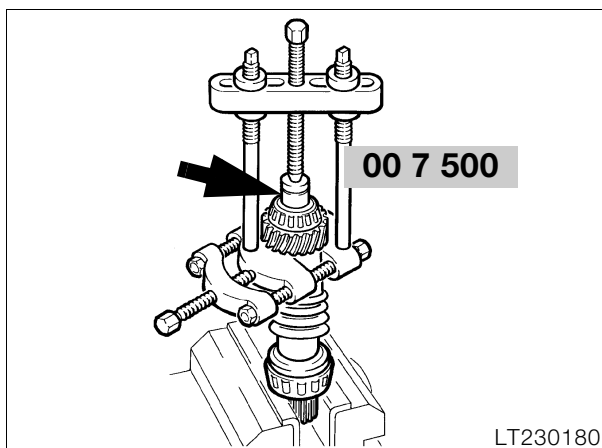

- Clamp spline end of input shaft in vice with jaw guard.
- Remove retaining ring (1).
- Using universal puller, **BMW No. 00 7 500**, and pressure tool (arrow), remove spur gear (3) together with taper roller bearing (2).
- Also remove second taper roller bearing.

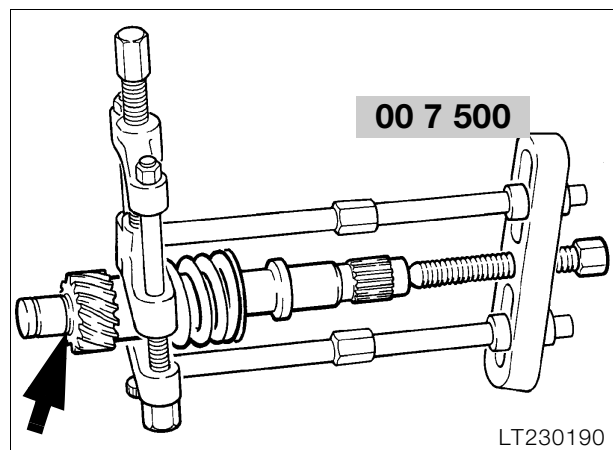

- Fit washer (6), coil spring (5), thrust piece (4) and spur gear (3) on input shaft.
- Using universal puller, tension spur gear against coil spring until the 2nd groove (arrow) can be seen ahead of the spur gear.
- Heat taper roller bearing to 100 °C and fit in position.
- Fit retaining ring (1) in front of the taper roller bearing.

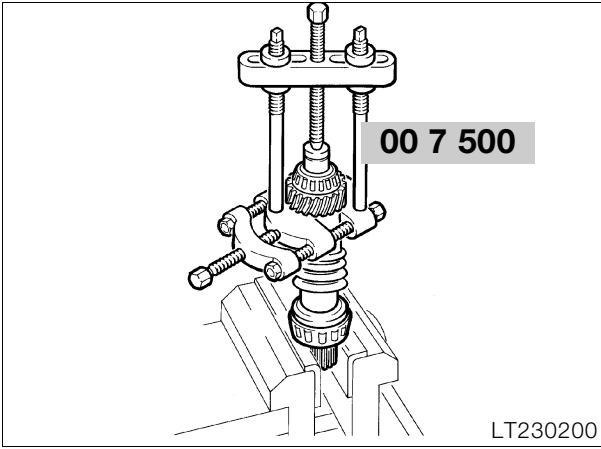

- Fit universal puller under the spur gear and pull down taper roller bearing as far as it will go on the retaining ring.



Note:

There must be no clearance between the bearing and retaining ring in order to precisely determine the thickness of the spacer!

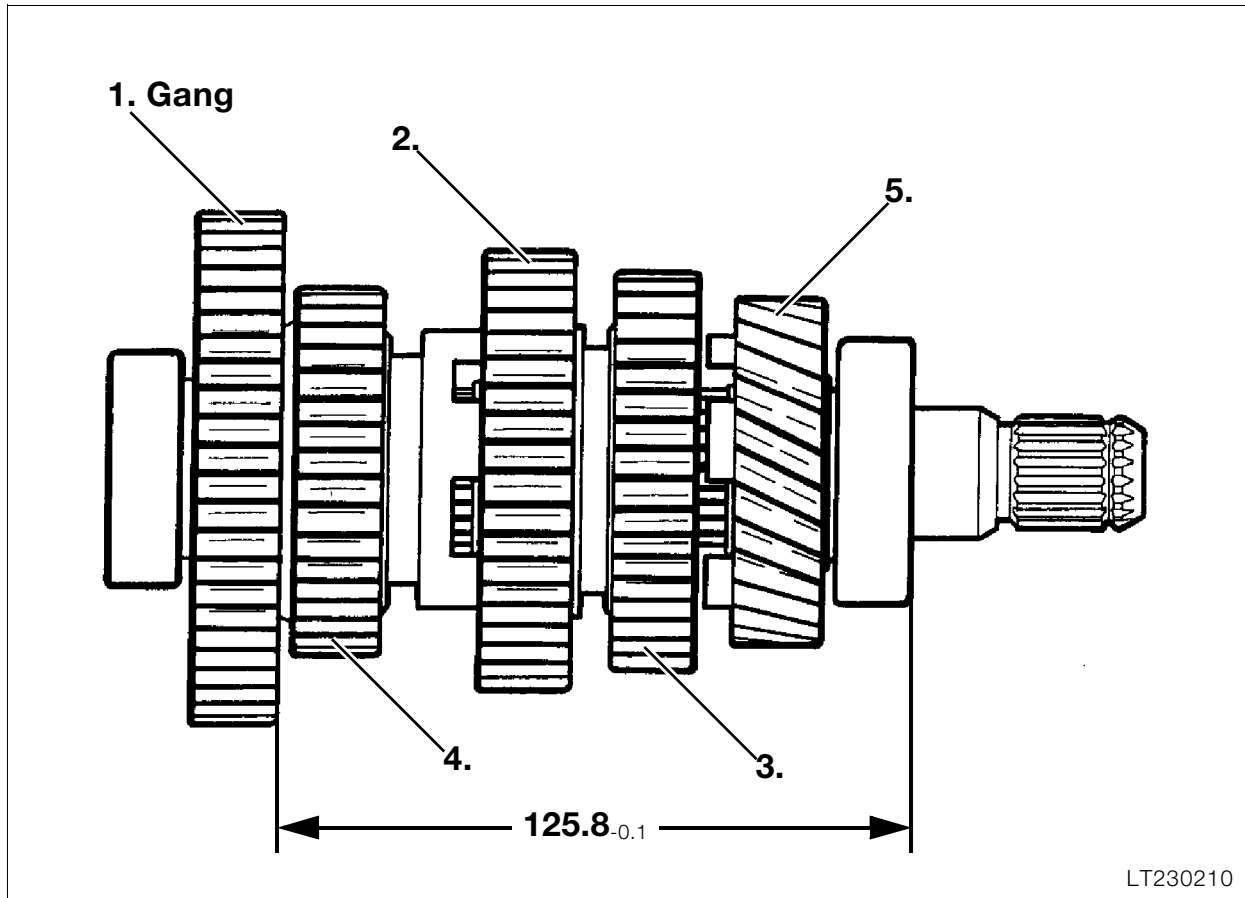

LT230210

Disassembling and assembling output shaft

- Before disassembling, measure axial clearance of spur gear for 1st, 2nd and 5th gears.

1st gear 0.10...0.30 mm (0.003937...0.01181in)

2nd gear ... 0.20...0.60 mm (0.007874...0.02362in)

5th gear 0.20...0.40 mm (0.007874...0.01575in)

- Set axial clearance with spacer shim rings.
- As part of the overall dimension, the spacer ring is fitted between the spur gear for 1st and 4th gear.

Removing ball bearing

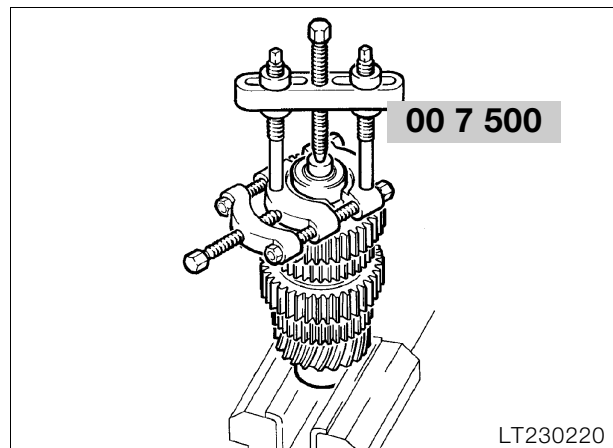

- Clamp output shaft in vice with jaw guards.
- Remove ball bearing with universal puller, **BMW No. 00 7 500.**

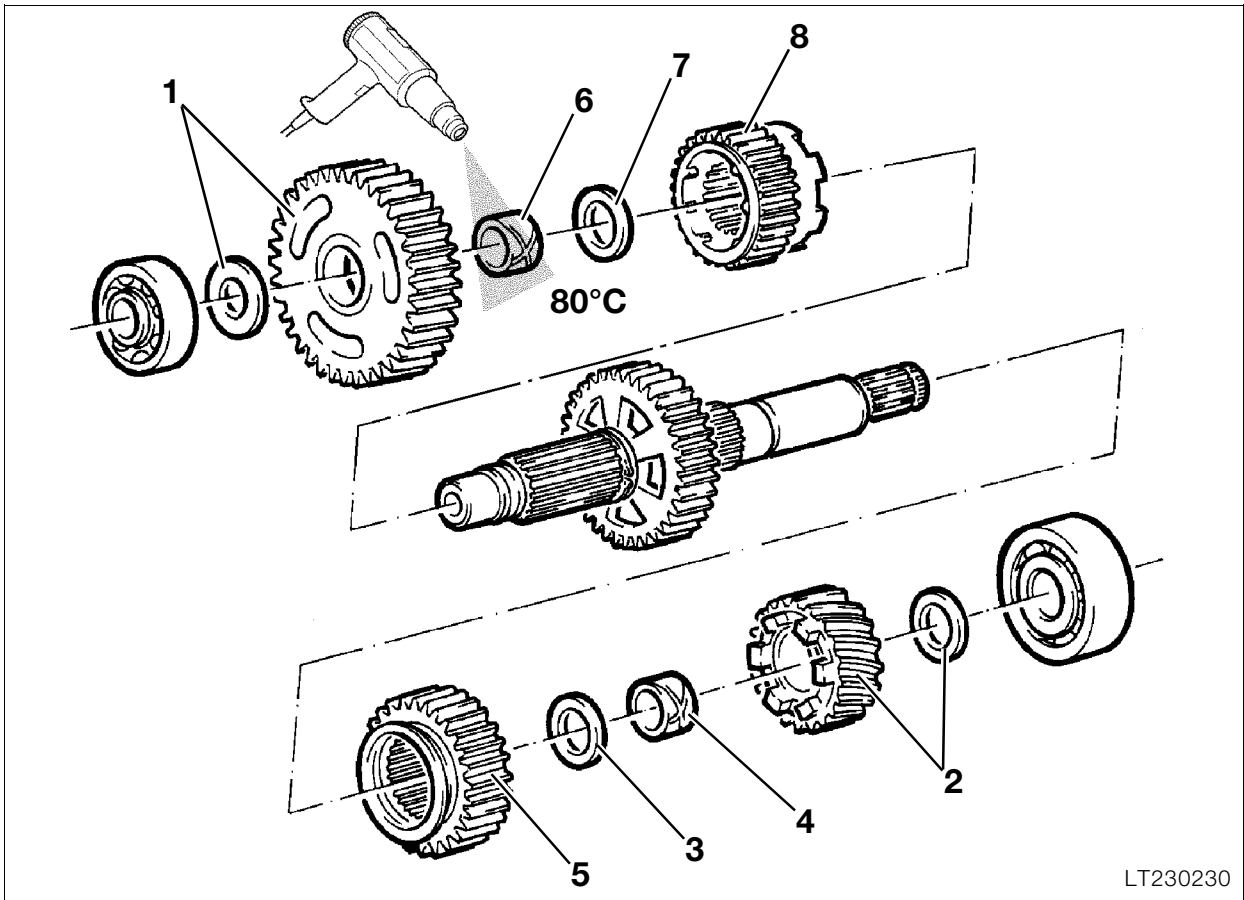

LT230230

Removing spur gears

- Remove spur gear for 1st (1) and 5th gear (2) with spacer shim rings.
- Heat bearing bush (4) to 80 °C.

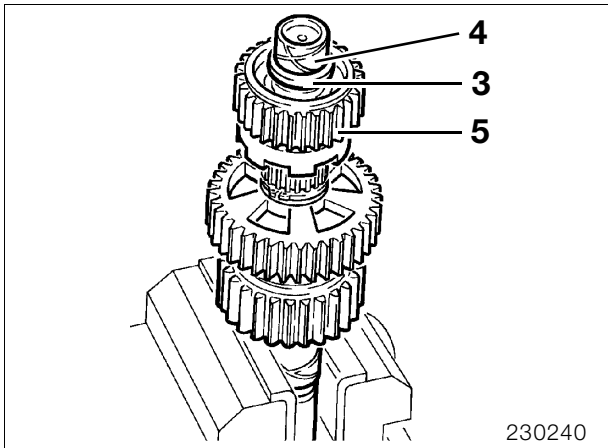

230240

- Carefully remove spur gear for 3rd gear (5) together with spacer shim ring (3) and bearing bush (4).
- Heat bearing bush (6) to 80 °C.
- Carefully remove spur gear for 4th gear (8), spacer shim ring (7) and bearing bush (6).

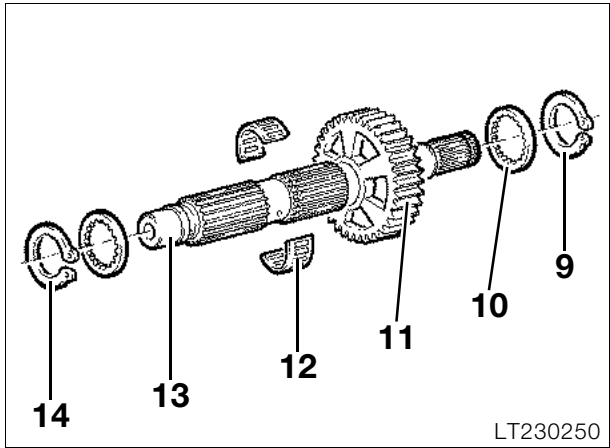

LT230250

- Remove retaining ring (9).
- Remove serrated washer (10).
- Remove spur gear for 2nd gear (11).
- Remove split needle cage (12).
- Remove serrated washer (13) and retaining ring (14).

Installing spur gears

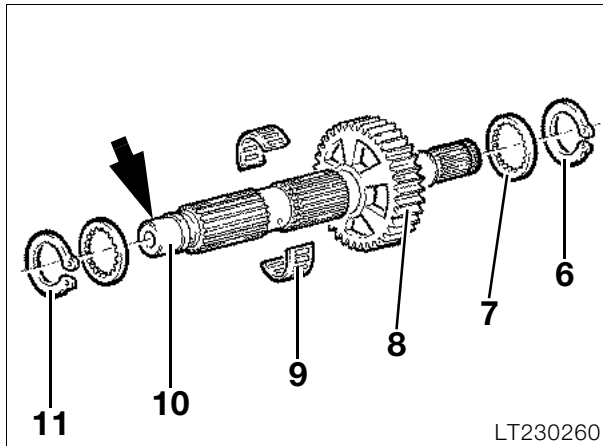

LT230260

- Slide serrated washer (10) over smooth end (arrow) onto output shaft up to the bearing seat.
- Slide on retaining ring (11) and fit in groove ahead of serrated washer.
- Fit split needle cage (9) well oiled.
- Slide spur gear for 2nd gear (8) from the spline side over the needle cage with the window side first.
- Fit serrated washer (7) followed by retaining ring (6).

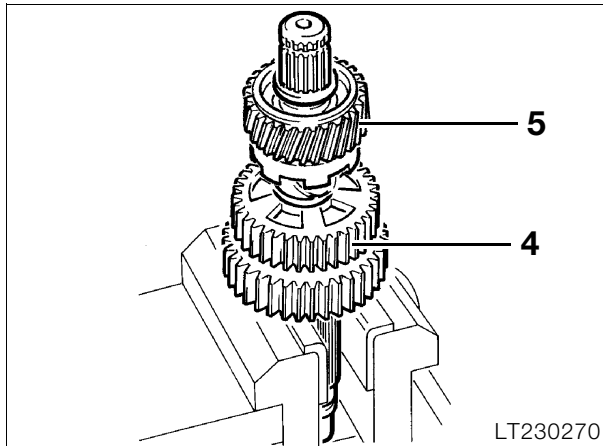

LT230270

- Clamp output shaft in vice with jaw guards, spline facing upward.
- Fit spur gear for 3rd gear (4) with windows facing upwards.
- Fit spacer shim ring.
- Heat wide bushing to 80 °C and slide on up to the spacer shim ring.
- Fit spur gear for 5th gear (5) with claws facing downward.
- Fit spacer shim ring.
- Heat ball bearing up to 80 °C and slide on up to the spacer shim ring.

- Turn output shaft in vice, splines facing downward.
- Fit spur gear for 4th gear (1), claws facing downward.
- Fit spacer shim ring.

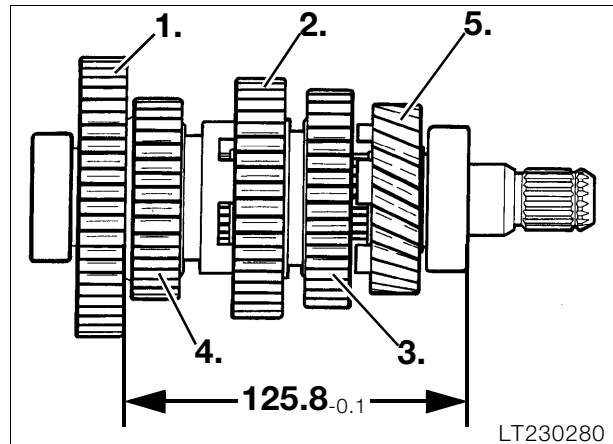

LT230280

- Check dimension 125.8 mm (4.9528 in), include spacer shim ring between spur gears for 1st and 4th gear.
- Heat narrow bushing to 80 °C and slide on up to the spacer shim ring.



Note:

Wide bushes are fitted on the spline side.

- Fit spur gear for 1st gear with smooth side facing upward.
- Fit spacer shim ring.
- Heat ball bearing to 80 °C and fit.
- As a check measure the axial clearance of the spur gears.

1st gear 0.10...0.30 mm (0.003937...0.01181in)
 3rd gear ... 0.20...0.60 mm (0.007874...0.02362in)
 5th gear ... 0.20...0.40 mm (0.007874...0.01575in)

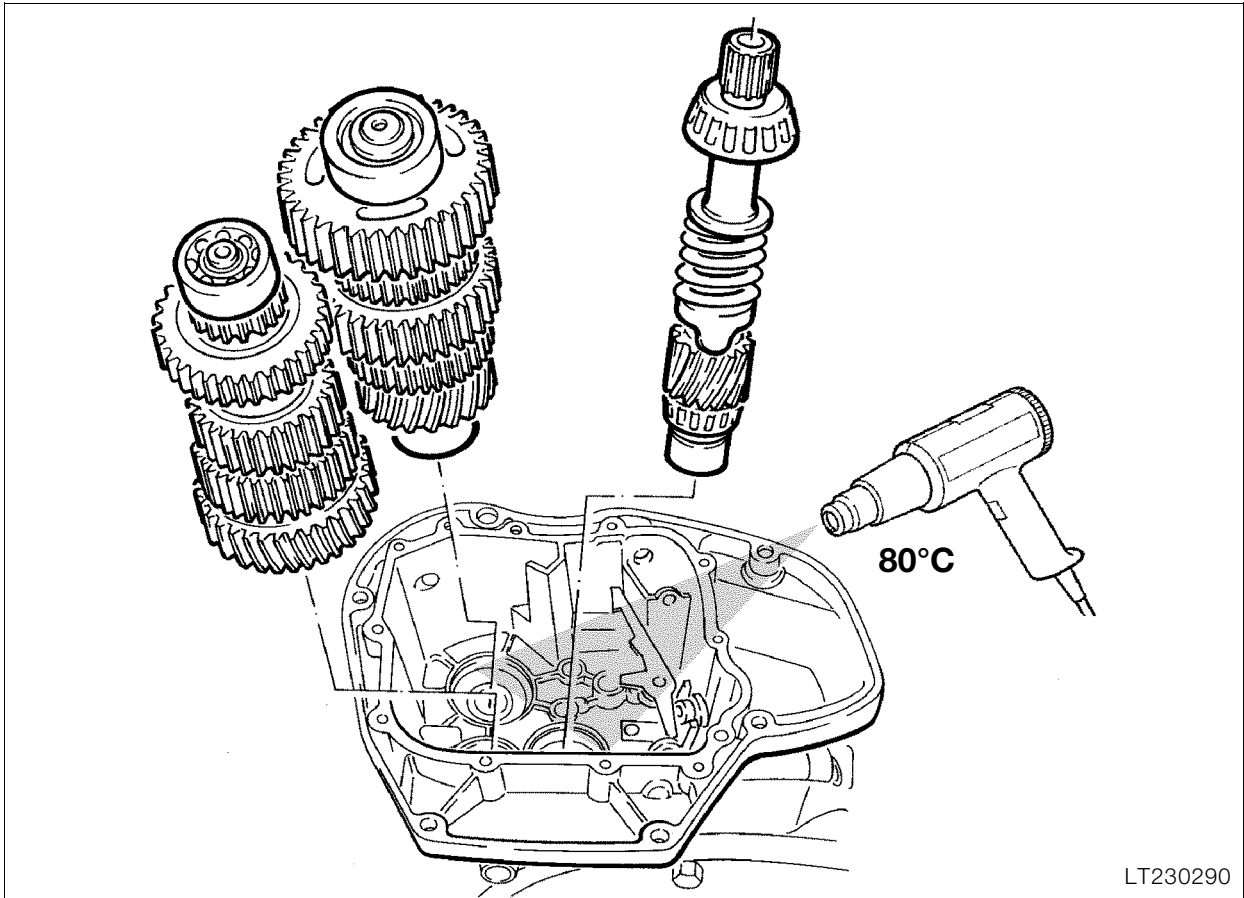

LT230290

Installing transmission shafts

- Heat bearing points for intermediate shaft and output shaft in the housing to 80°C.
- Fit input shaft.
- Install intermediate shaft and output shaft together.
- With the aid of light blows (plastic-headed hammer), check that bearing is fitted in the base of the seat.

- Fit gearshift forks for 1st and 2nd gear (2) with short guide end facing downward in the upper section of the output shaft.
- Fit gearshift fork for 3rd and 4th gear (3) with short guide end facing downward in the intermediate shaft.



Note:

Lightly coat sleeves of guide pins with grease when fitting.

Installing gearshift forks

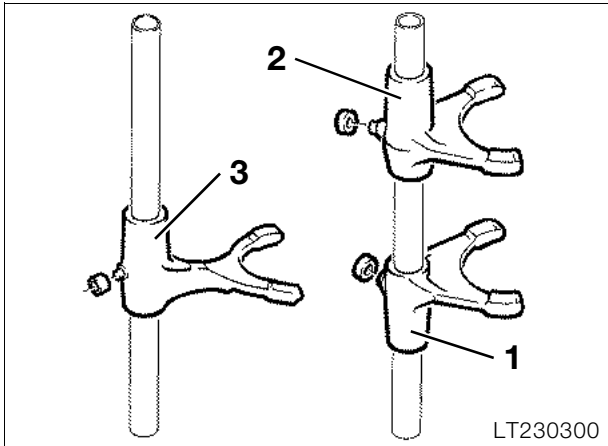

LT230300

- Fit gearshift fork for 5th gear (1) with short guide end facing upward in the bottom section of the output shaft.

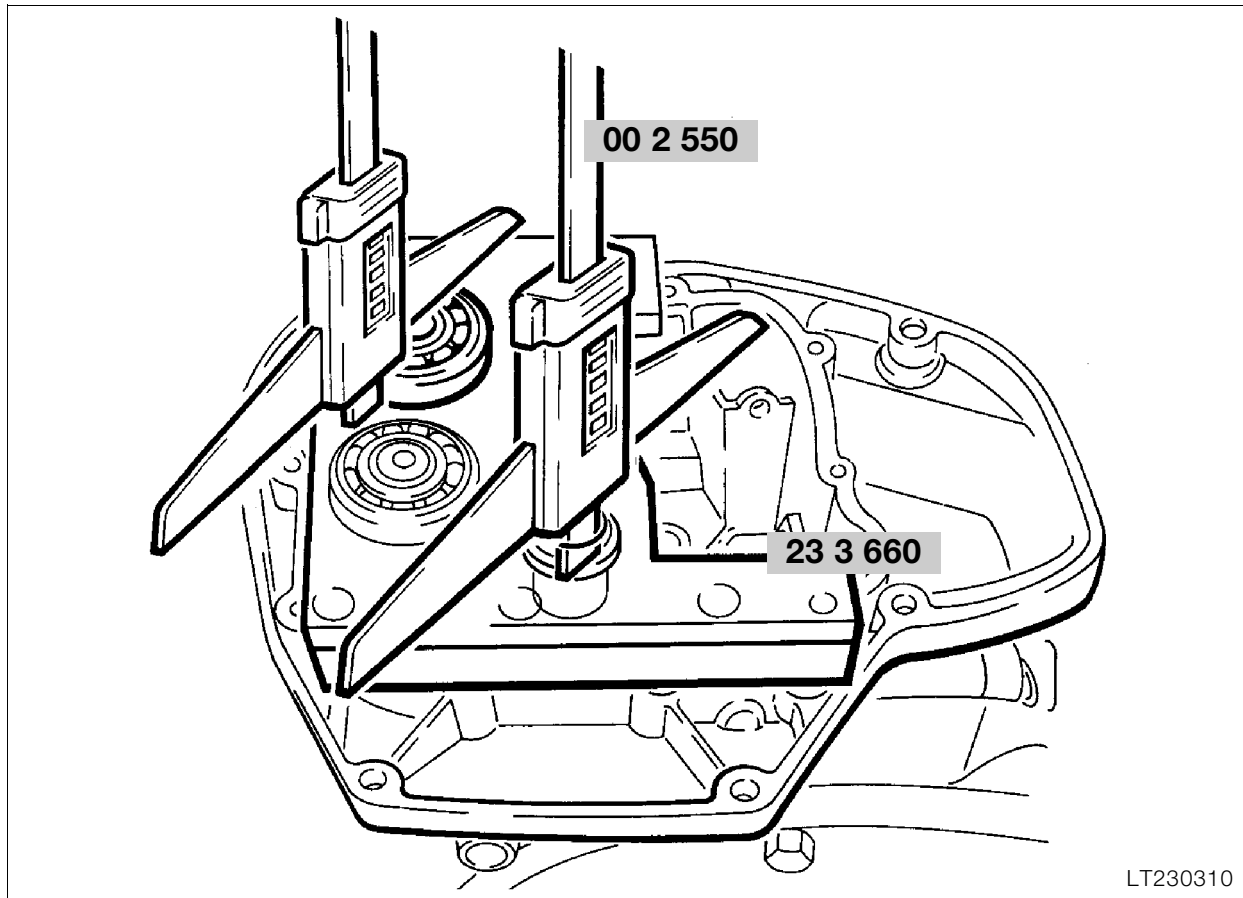

LT230310

Measuring distances between transmission shafts

Measuring bearing distance of shafts

- Place transmission measuring plate, **BMW No. 23 3 660** (arrow), on the transmission housing.
- Measuring procedure for intermediate shaft and output shaft:
Using depth gauge, **BMW No. 00 2 550**, measure distance between ball bearing outer race and measuring plate. Before measuring, knock the corresponding shaft to the base of its seat.
- For the input shaft, measure through the window in the measuring plate the distance from the bearing collar to the measuring plate.
- Enter all measurements in a table, see example.



Note:

The dimension for the input shaft must be entered with a negative sign in the table!

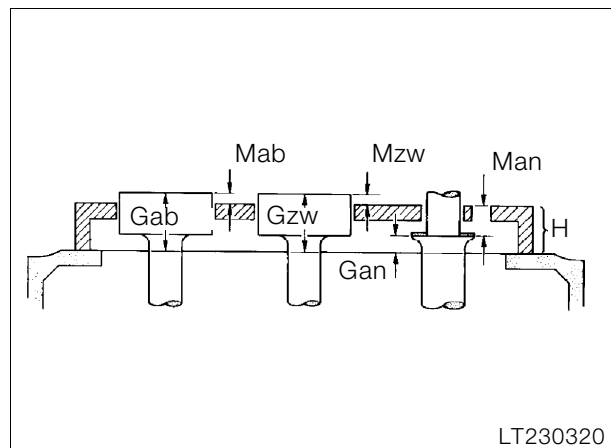

LT230320

Mab = Dimension output shaft to measuring plate

Mzw = Dimension intermediate shaft to measuring plate

Man = Dimension measuring plate to collar on input shaft

H = Height of measuring plate

Total measurement:

$Gab = Mab + H$

$Gzw = Mzw + H$

$Gan = H - Man$

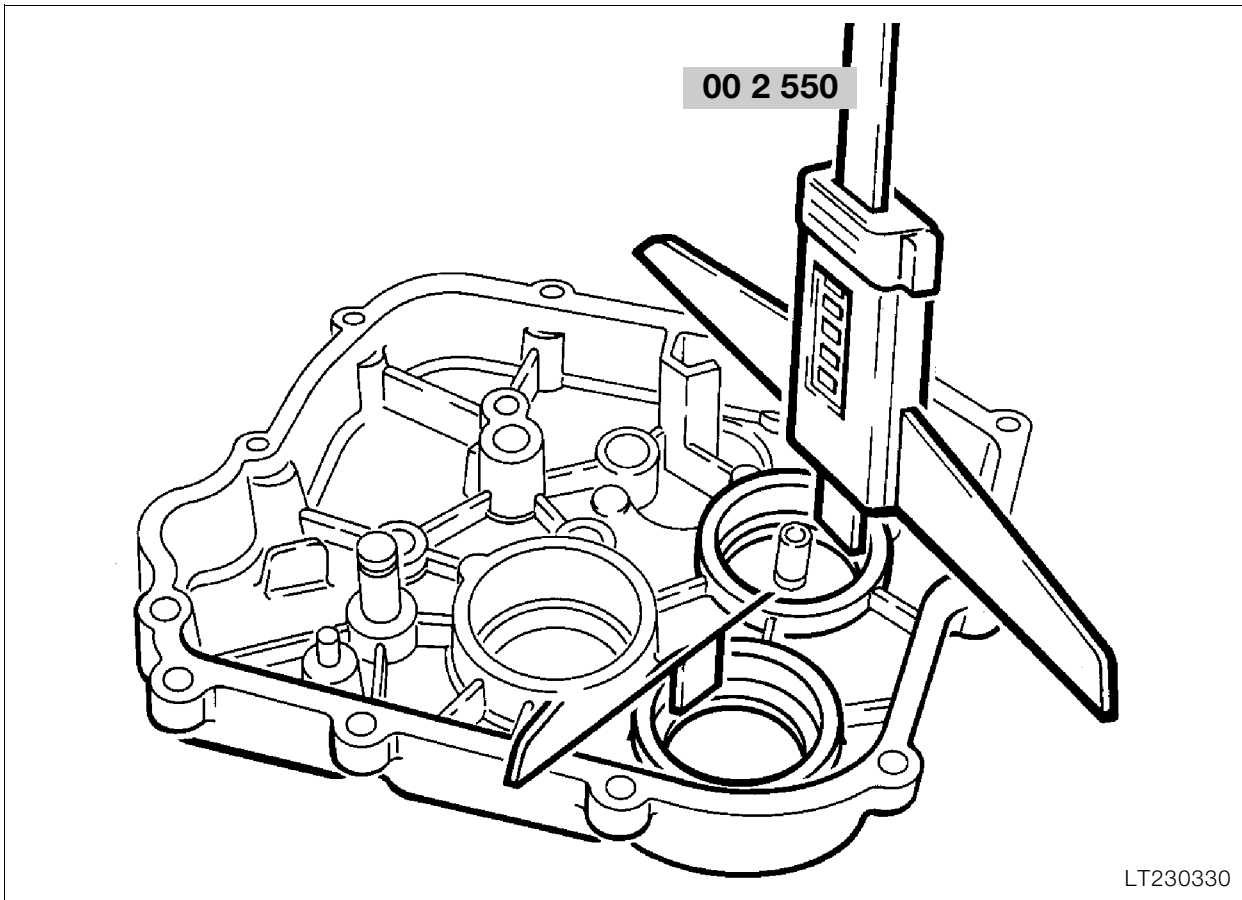

LT230330

Measuring transmission cover

- Measure from the parting surface of the transmission cover to the base of the bearing seat.
- Only applies to intermediate shaft and output shaft

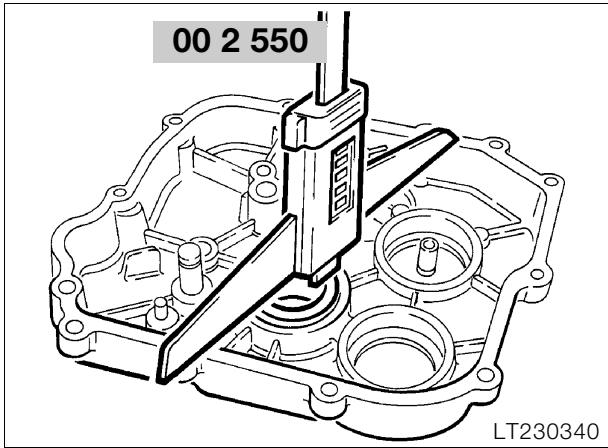

LT230340

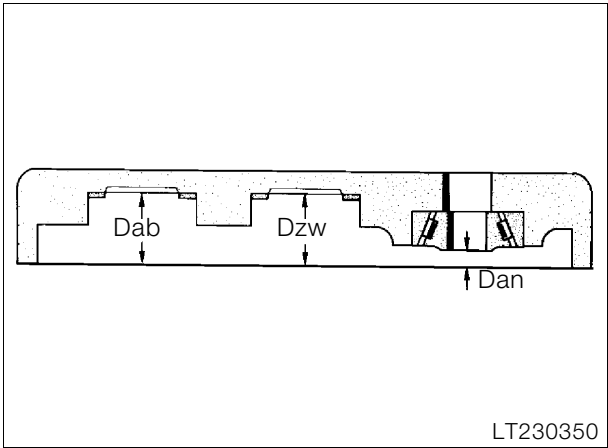

LT230350

Dab = Cover dimension output shaft
 Dzw = Cover dimension intermediate shaft
 Dan = Cover dimension input shaft

Permissible axial clearance:
 Intermediate shaft and output shaft... 0.05...0.15 mm (0.00197...0.0059 in)

Permissible preload:
 Input shaft... 0.03...0.08 mm (0.00118...0.00315 in)

- The dimension for the input shaft is measured with the taper roller bearing installed.
- Measure from bearing inner face to parting surface of transmission cover.
- Enter all measurements in a table, see example.

Measuring distances between transmission shafts

Example:

Maße in mm (in)	Output shaft "ab"	Intermediate shaft	Input shaft "an"
H	30.00 (1.1811 in)	30.00 (1.1811 in)	30.00 (1.1811 in)
+ M (measure!)	5.45 (0.2146 in)	6.05 (0.2382 in)	-20.10 (-0.7913 in)
= G	35.45 (1.3957 in)	36.05 (1.4193 in)	9.90 (0.3897 in)
D (measure!)	36.40 (1.4331 in)	36.90 (1.4528 in)	11.30 (0.4449 in)
- G	-35.45 (-1.3957 in)	-36.05 (-1.4193 in)	- 9.90 (-0.3897 in)
= clearance without spacer shim rings	0.95 (0.0374 in)	0.85 (0.0335 in)	1.40 (0.0551 in)
- specified axial clearance	- 0.05 (-0.00197 in)	- 0.05 (-0.00197 in)	+ 0.05 (+0.00197 in)
= thickness of spacer shim ring	0.90 (0.0354 in)	0.80 (0.0315 in)	1.45 (0.0571 in)

- Remove measuring plate from transmission housing.
- Fit calculated spacer shim rings on the input shaft.
- Heat taper roller bearing to 80°C and fit on input shaft.
- Lightly grease spacer shims for intermediate shaft and output shaft and fit flush on ball bearing.

Installing transmission cover

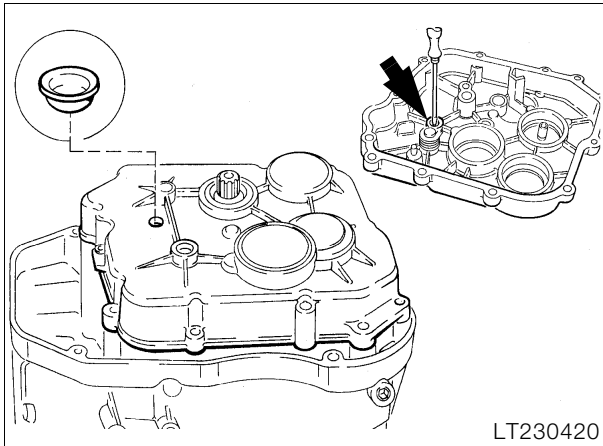

- Knock out cap (arrow) from the inside using a drift.
- Heat up transmission cover to 100°C.
- Parting surface at housing and cover must be clean and free of grease.
- Thinly coat one of the two parting surfaces with **Loctite 574** or with **Three-Bond 1209**.

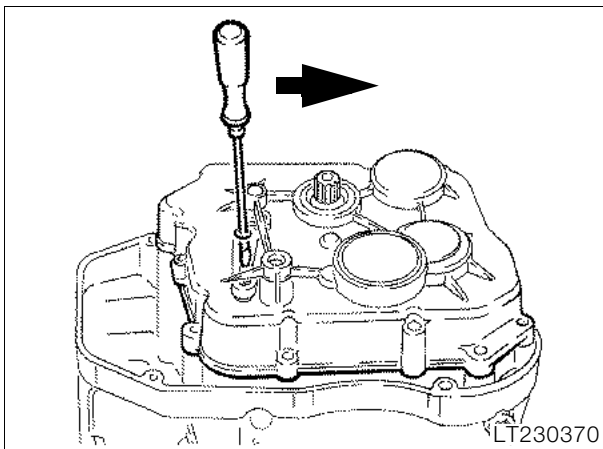

- With the aid of a drift or screwdriver, press back locking lever in direction shown by arrow.
- Carefully fit cover on the housing.
- Screw in screws holding transmission cover and firmly tighten.

 **Tightening torque:**
Retaining screws for cover 9 Nm

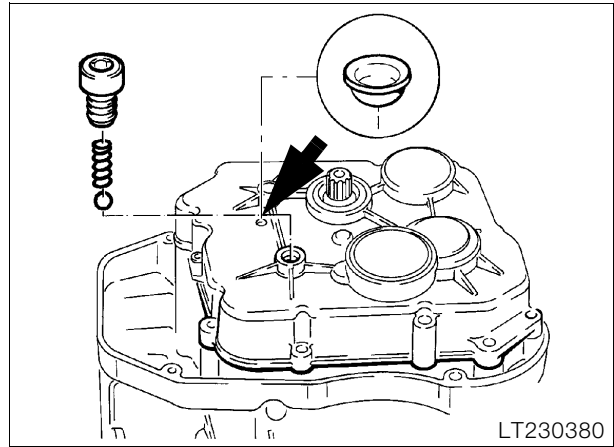

- Thinly coat end cap (arrow) with **Three-Bond 1209** and knock in with drift by 8 mm (0.31496 in).
- Fit idle lock (ball and spring) in idle position.
- Screw in screw for idle lock coated with **Loctite 243**.

 **Tightening torque:**
Screw for idle lock 13 Nm

Installing transmission (gearbox)

- Clutch thrust bearing must be removed.
- Check centre position of driving disk.
- Coat spline of input shaft, for example with **Optimoly MP 3**.

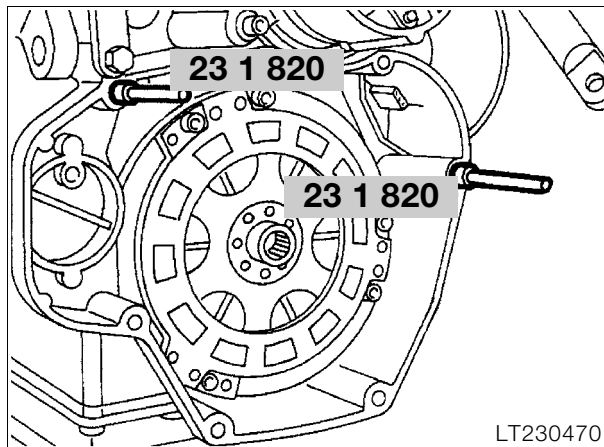

- Screw guide pins, **BMW No. 23 1 820**, in the holes with centring sleeve in the intermediate flange.
- Screw in long pin on right-hand side.

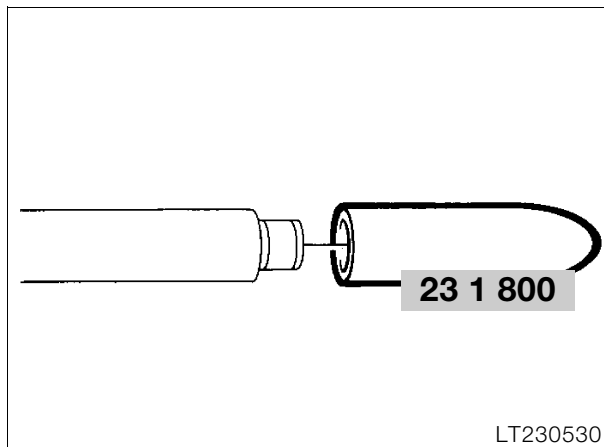

- Fit slip sleeve, **BMW No. 23 1 800**, on control rod.
- Fit control rod from front through the input shaft.
- Place transmission on guide pins (oiled) and carefully slide into position.

 **Tightening torque:**
Transmission to intermediate flange..... 16 Nm

- Install clutch thrust bearing.

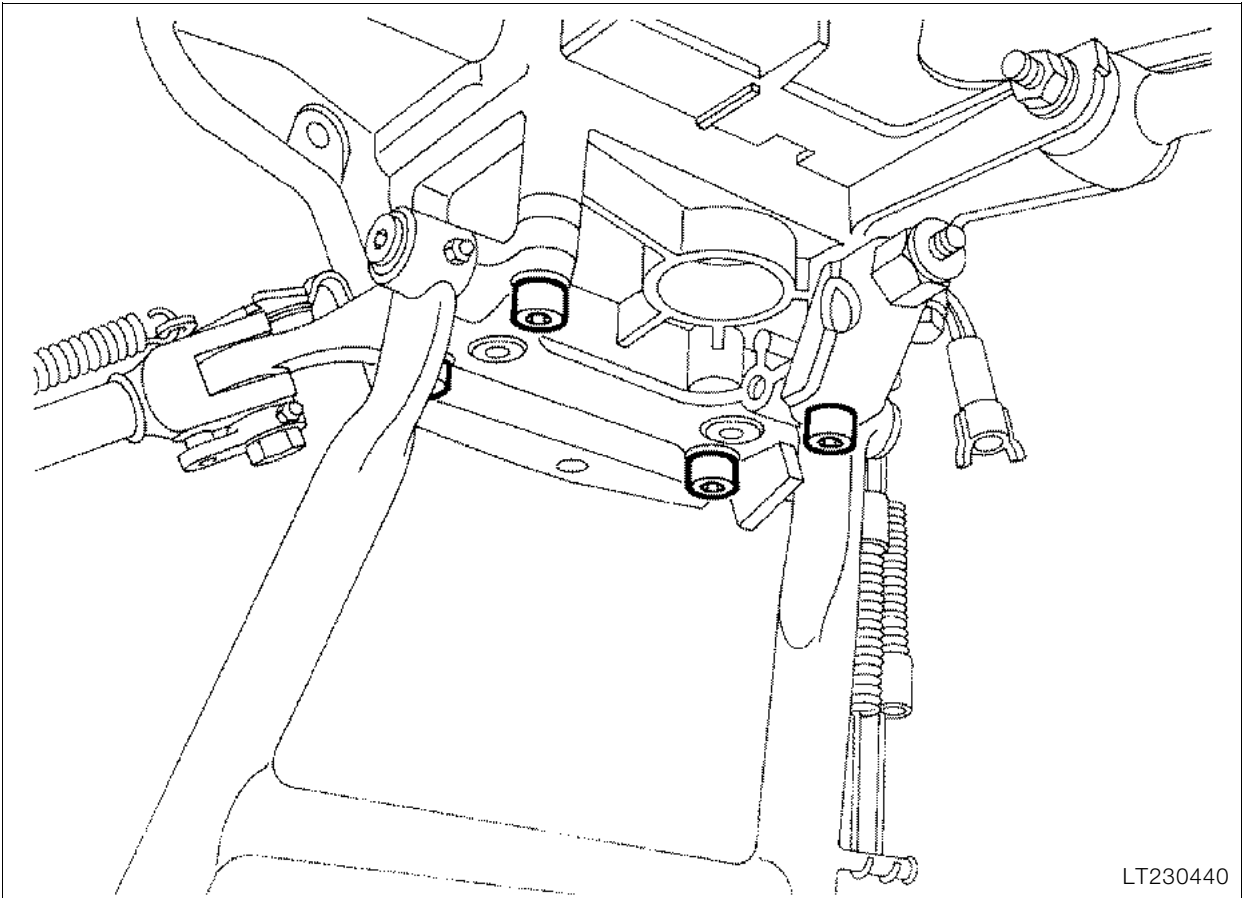

LT230440

Installing bearing mount with main stand

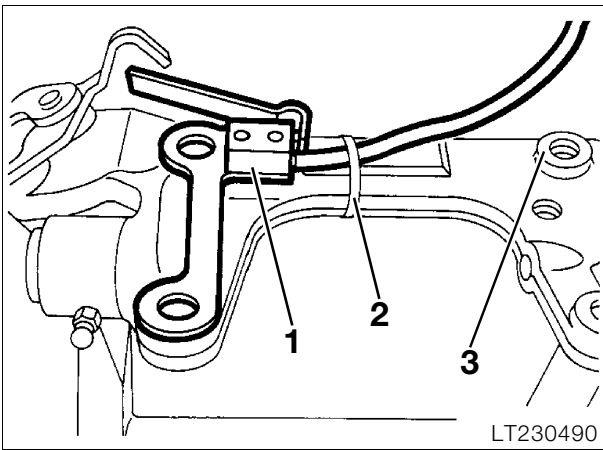

LT230490

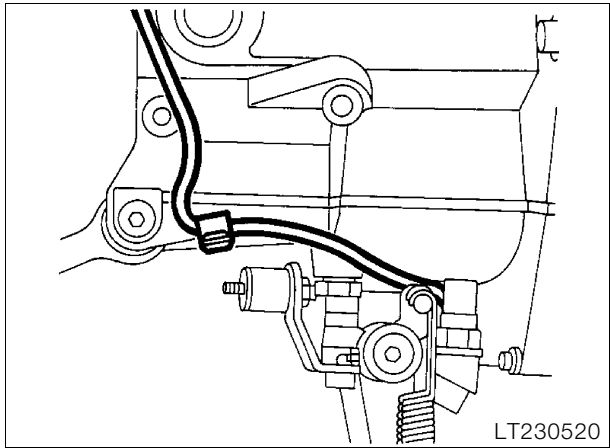

LT230520

- Note line arrangement for electrical side stand.



Note:

Clean threaded holes in transmission and retaining bolts (recut thread).

- Place switch (1) for electric side support on bearing mount, secure lead with cable clip (2).
- Note spacer sleeves (3).
- Coat bolts with **Loctite 243**, screw in and firmly tighten.



Tightening torque:

Bearing mount to transmission..... 41 Nm

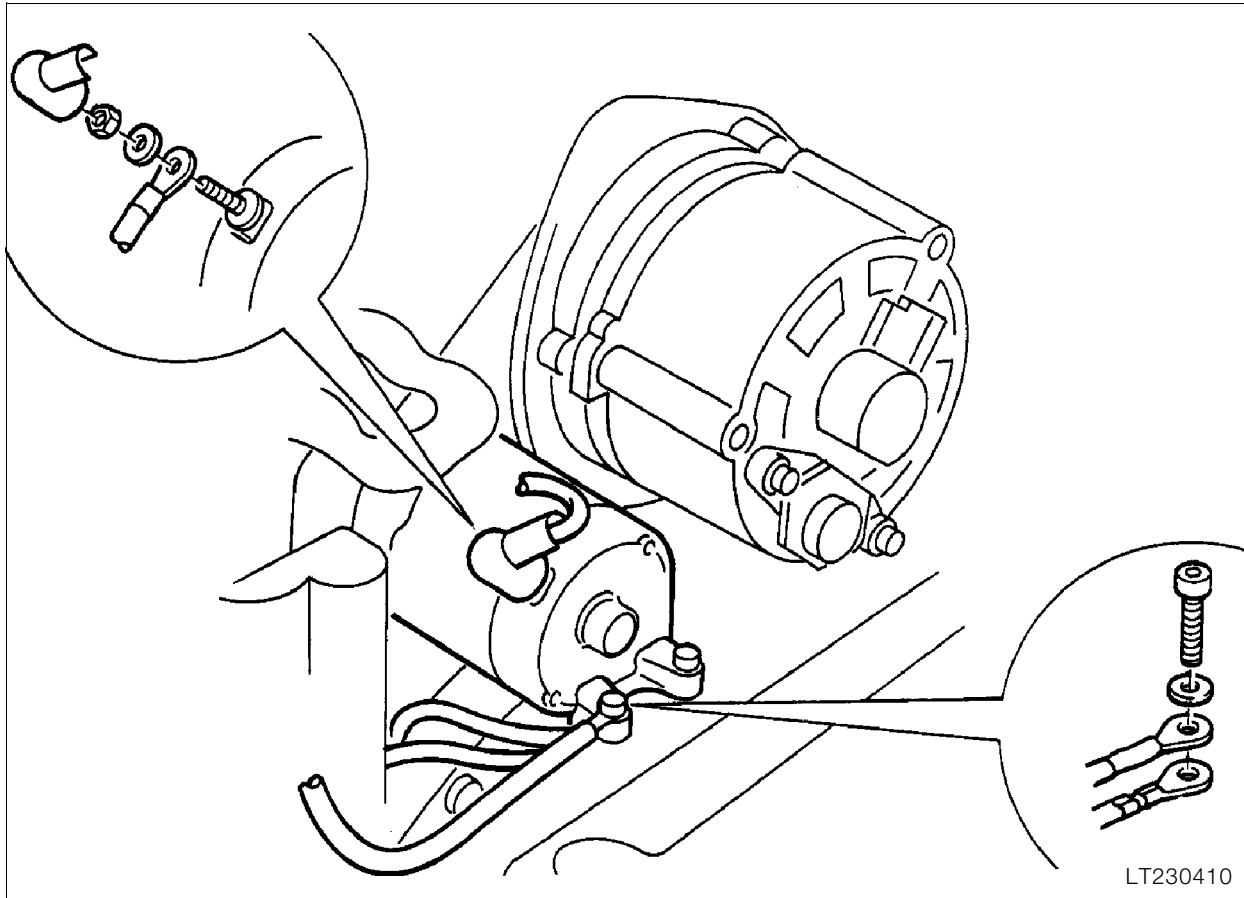

Installing starter

- Connect positive and negative leads.

 **Tightening torque:**

Positive lead	5 Nm
Starter to transmission	9 Nm

- **[ABS I]** Install support bracket for pressure modulators.



Note:

Note arrangement of wiring loom.

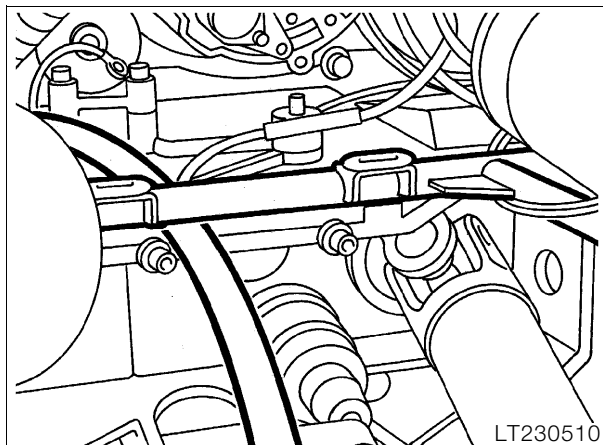

Re-assembling motorcycle

- Install battery.
- Install Motronic control unit.
- **[ABS II]** Install ABS unit.
- Install battery.
- Install Motronic control unit.
- **[ABS I]** Install control unit.
- Install swinging arm.
- Install footrest plates.
- **[ABS I]** Install pressure modulators.
- Install rear wheel drive.
- Install suspension strut.
- Install rear wheel.
- Install brake caliper



Note:

Check ABS sensor gap.

- Install exhaust system.
- Install rear mudguard.
- Install side section of fairing.



Tightening torques:

Fixed swinging arm bearing at gearbox	8 Nm
Fixed swinging arm bearing journal, free bearing	7.5 Nm
Locknut, free bearing	41 Nm
Bearing pin of fixed bearing	150 Nm (clean thread + Loctite 2701)
Bearing pin of loose bearing	7 Nm (clean thread + Loctite 2701 applied to entire length of thread on loose bearing pin)
Locknut	105 Nm
Suspension strut to frame/rear wheel drive ..	51 Nm
Rear wheel studs	105 Nm
Exhaust pipes to cylinder head	21 Nm
Exhaust system to holder/footrest plate	9 Nm
Front silencer (muffler) to gearbox	12 Nm
Footrest plate to gearbox	15 Nm

31 Front fork

Inhalt	Seite
Technical Data	3
Removing telescopic fork	5
Removing fork stabilisor	5
Removing telescopic fork without fork bridge	5
Removing telescopic fork with fork bridge	5
Removing upper fork bridge	5
Removing and installing lower taper roller bearing	6
Removing taper roller bearing	6
Installing taper roller bearing	6
Removing and installing upper taper roller bearing	6
Removing taper roller bearing	6
Installing taper roller bearing	6
Removing and installing bearing outer race in steering head	7
Removing bearing outer race	7
Installing bearing outer race	7
Measuring telescopic fork	8
Checking lower fork bridge	8
Checking parallel alignment of fixed tubes	9
Checking runout of fixed tube	10
Disassembling telescopic fork	11
Removing fixed tube	11
Disassembling slider tube	11
Disassembling fixed tube	12
Assembling telescopic fork	14
Assembling fixed tube	14
Assembling slider tube	16
Installing telescopic fork	17
Adjusting steering bearing play	18
Installing fork stabilisor	19

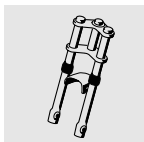

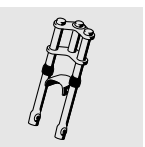

Technical Data		K 1100 LT	K 1100 RS
Front wheel castor	mm (in)	95 (3.74)	
Steering angle	°	34	
Spring travel (normal position, 75 kg load)	mm (in)	135 (5.315)	
Test installation length of fixed tubes	mm (in)	ca. 210 (approx. 8.268)	
Fixed tube surface		hart verchromt	
Fixed tube outside ø	mm	41.7 f ^B	
Slider tube inside ø	mm	41.86 H ^B	
Clearance of fixed fork tube in slider tube	mm (in)	0.05...0.209 (0.00197...0.00823)	
Maximum permissible runout of fixed fork tube	mm (in)	0.15 (0.0059)	
Length of fork support spring	mm (in)	425 (16.732)	
Coil wire diameter of fork support spring	mm (in)	4.8 (0.189)	
Telescopic fork oil - approved grade		Esso Komfort	
Capacities per fork leg,			
Oil change, left	l (Imp. pt)	0.350 - 0.01 (0.616 - 0.0176)	
right	l (Imp. pt)	0.400 - 0.01 (0.704 - 0.0176)	
New filling	l (Imp. pt)	0.400 - 0.01 (0.704 - 0.0176)	
Grease in gaiter		SHELL Retinax A Gleitmo 805	

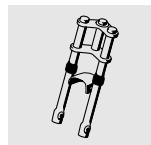

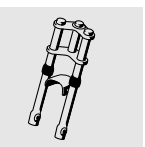

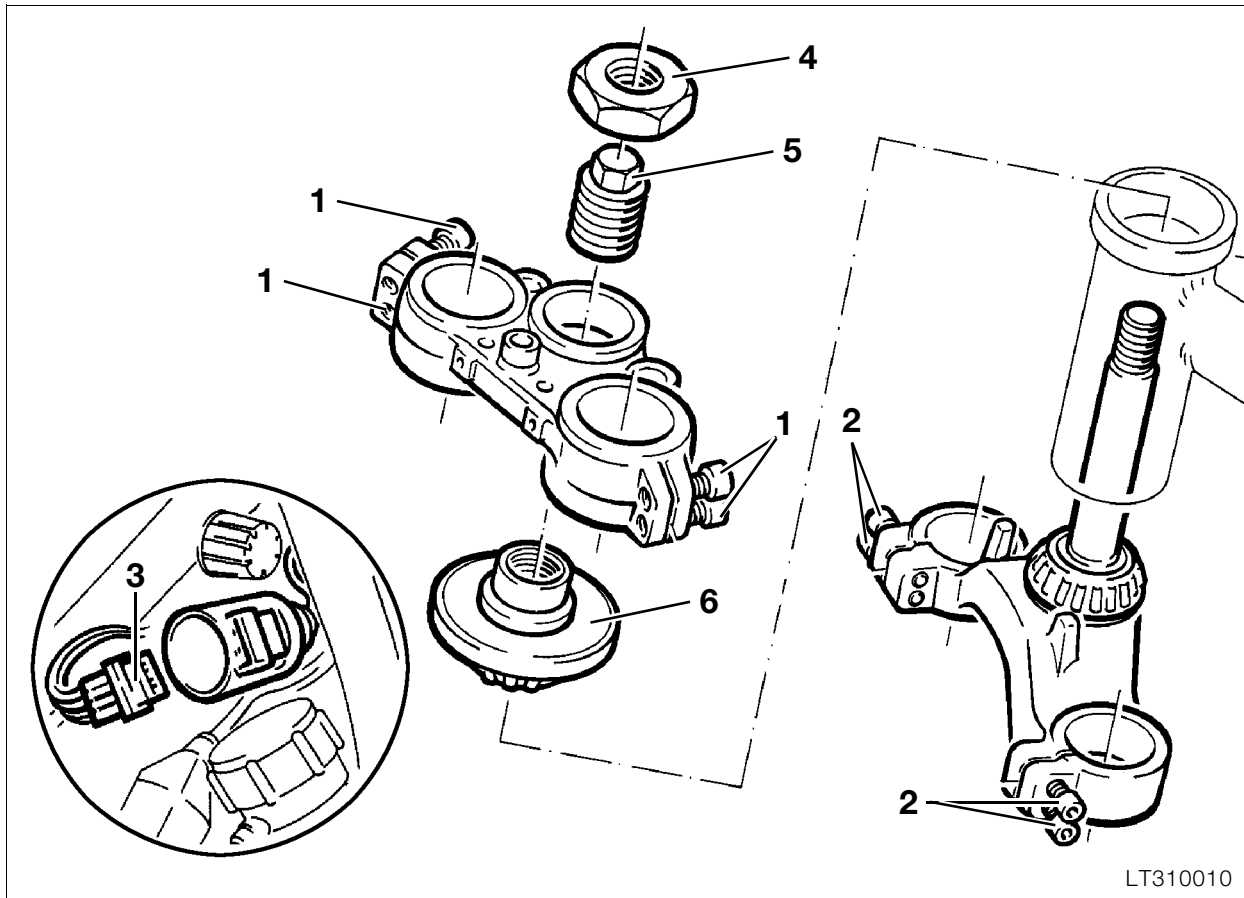

Removing telescopic fork

- Secure lifting gear, **BMW No. 00 1 510**, to oil sump.
- Remove fuel tank.
- Remove front mudguard.
- Remove brake caliper.

Removing fork stabilisor

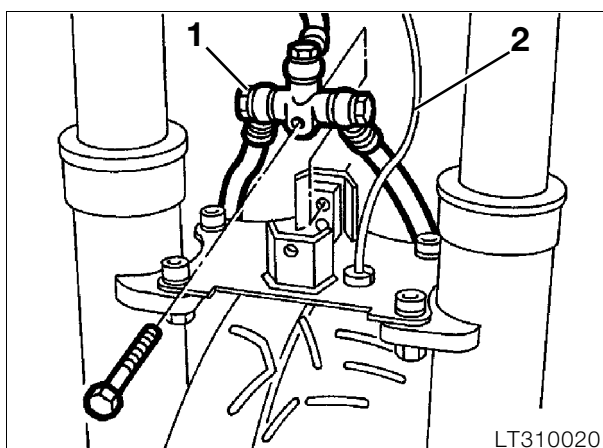

- Release brake distributor (1).
- Disconnect ABS plug connection of sensor line (2) under fuel tank.
- Remove fork stabiliser.
- Remove front wheel.
- Remove handlebar with fittings.

Removing telescopic fork without fork bridge

- Release clamping screws (1,2), pull down telescopic fork and remove.

Removing telescopic fork with fork bridge

Removing upper fork bridge

- Release hexagon nut (4).
- Release locking tube (5).
- Disconnect plug connection for ignition lock (3).
- Loosen clamping screws (1).
- Remove fork bridge.
- Remove setting ring (6).
- Remove fork by pulling from below together with light hammer blows (plastic-headed hammer) on the steering tube.

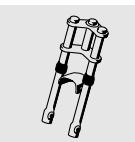

Removing and installing lower taper roller bearing

Removing taper roller bearing

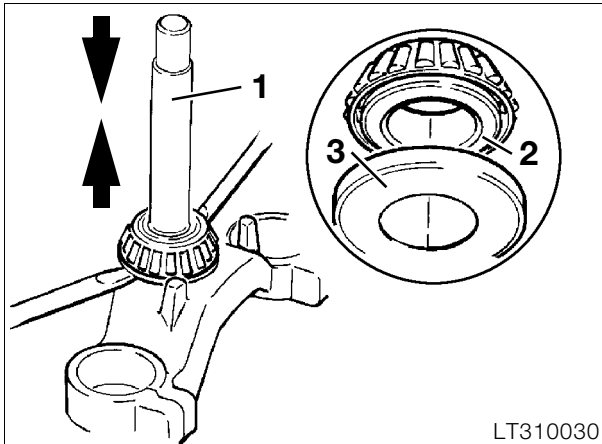

- Press down steering tube (1) by approx. 5 mm and press back again.
- Press off taper roller bearing (2) and dust ring (3) using two large screwdrivers.

Installing taper roller bearing

- Heat taper roller bearing to 80 °C and slide onto the steering tube together with the dust ring as far as it will go.



Note:

Dust ring must have no clearance!

- Grease bearing with, for example, **Shell "Retinax A"**.

Removing and installing upper taper roller bearing

Removing taper roller bearing

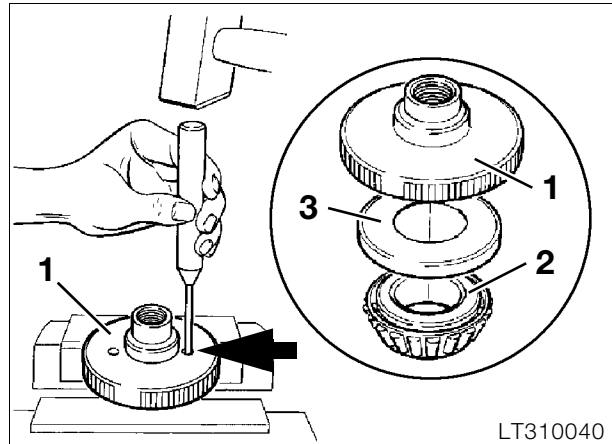

- Using a drift, knock out taper roller bearing together with dust ring (2,3) out of setting ring (1).

Installing taper roller bearing

- Heat taper roller bearing to 80 °C and press together with dust ring into setting ring.



Note:

Dust ring must have no clearance!

- Grease bearing with, for example, **Shell "Retinax A"**.



Removing and installing bearing outer race in steering head

Removing bearing outer race

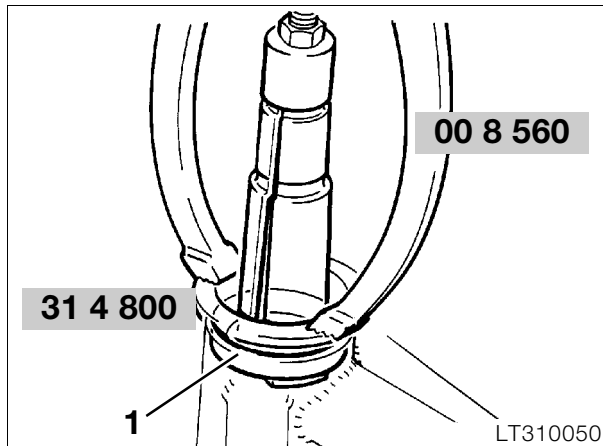

- Remove bearing outer race (1) using extractor BMW No. 00 5 560 (2), and support ring BMW No. 31 4 800 (3).



Caution:

Bearing and bearing outer race belong together, always fit together!

Installing bearing outer race

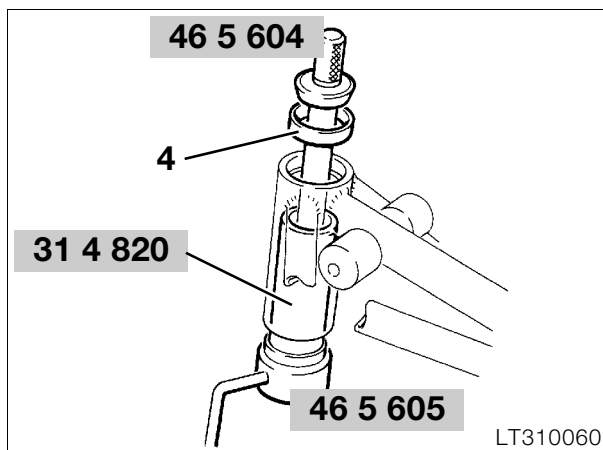

- With the aid of the spindle of the frame test gauge, **BMW No. 46 5 604/605**, in conjunction with the thrust piece, **BMW No. 31 4 820**, install bearing outer race (4) together with hexagon nut and washer to the limit stop.

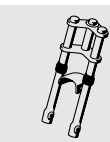

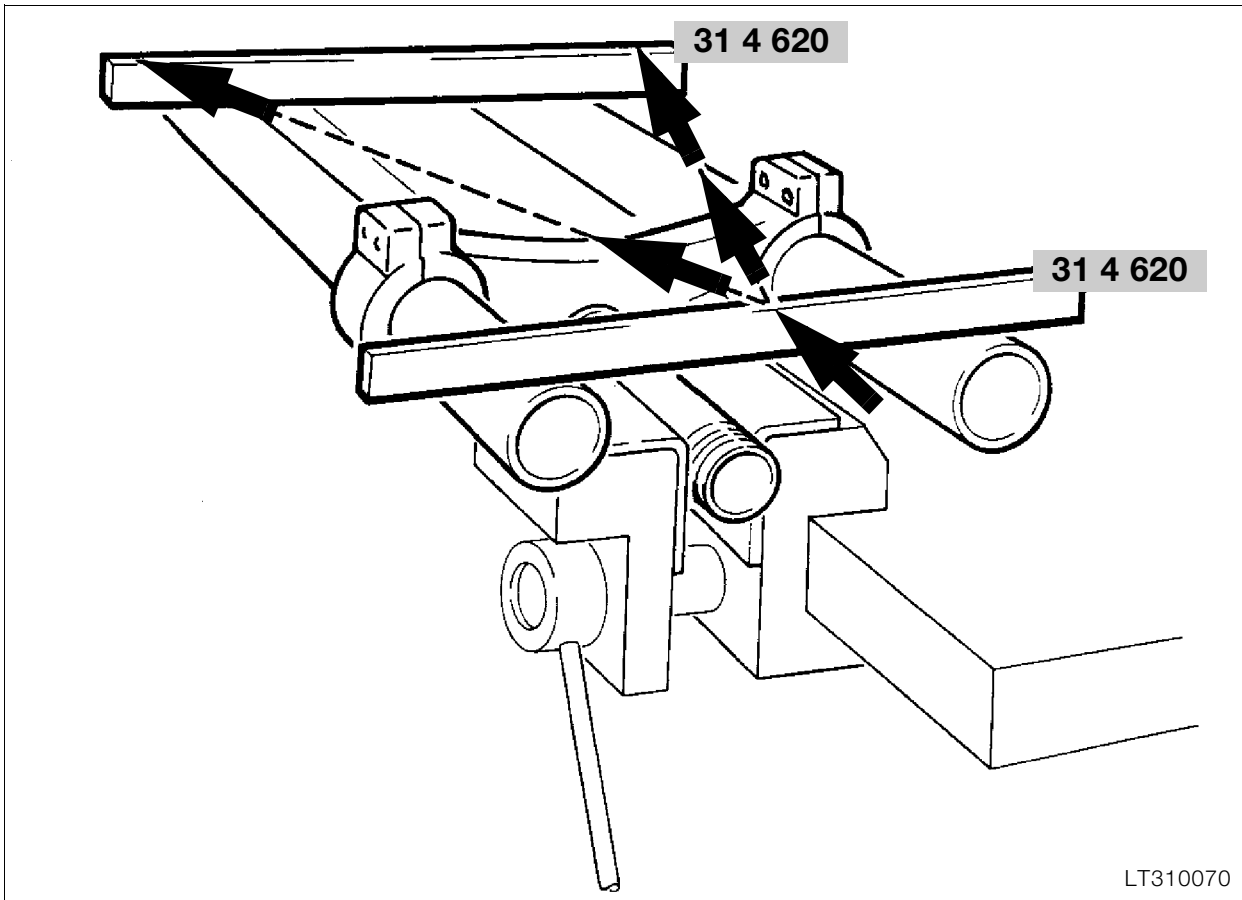

Measuring telescopic fork



Note:

After a collision, the telescopic fork must be examined for cracks and damage.

- Place two test straight edges, **BMW No. 31 4 620**, over the upper and lower ends of the fixed tubes.
- Determine any distortion by visual alignment (arrows).



Caution:

Replace distorted fork bridges.

Checking lower fork bridge

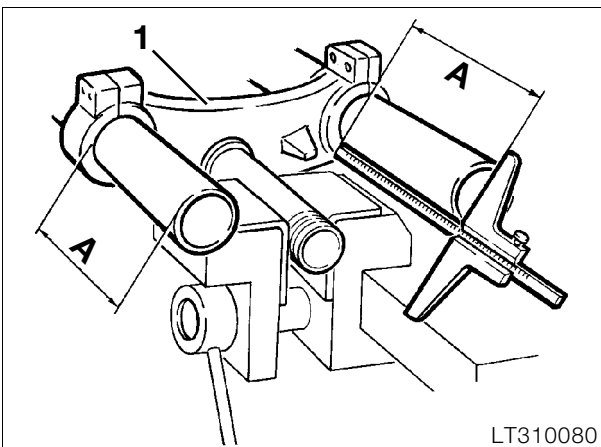

- Clamp fork bridge at steering tube in vice with jaw guards.
- Install two new fixed tubes with test length "A" in lower fork bridge (1).

Test installation length "A" 210 mm (8.268 in)

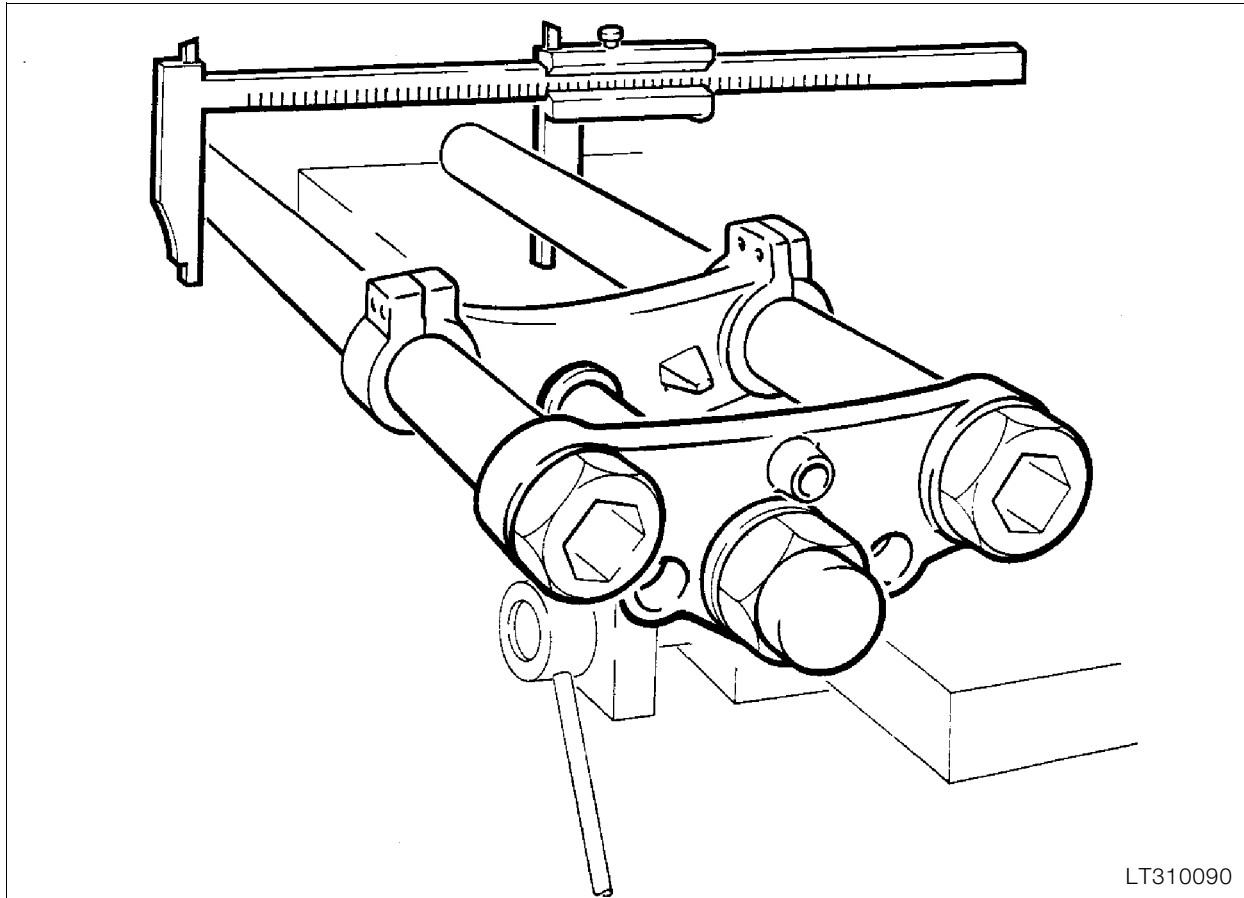

Checking parallel alignment of fixed tubes

- Clamp fork bridge at steering tube in vice with jaw guards.
- Install upper fork bridge.



Note:

Fork bridge must slide smoothly on to fixed tubes.

- Check parallel alignment of fixed tubes using slide gauge.
- Check flush alignment of steering tube with respect to fixed tube.

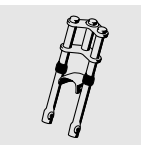

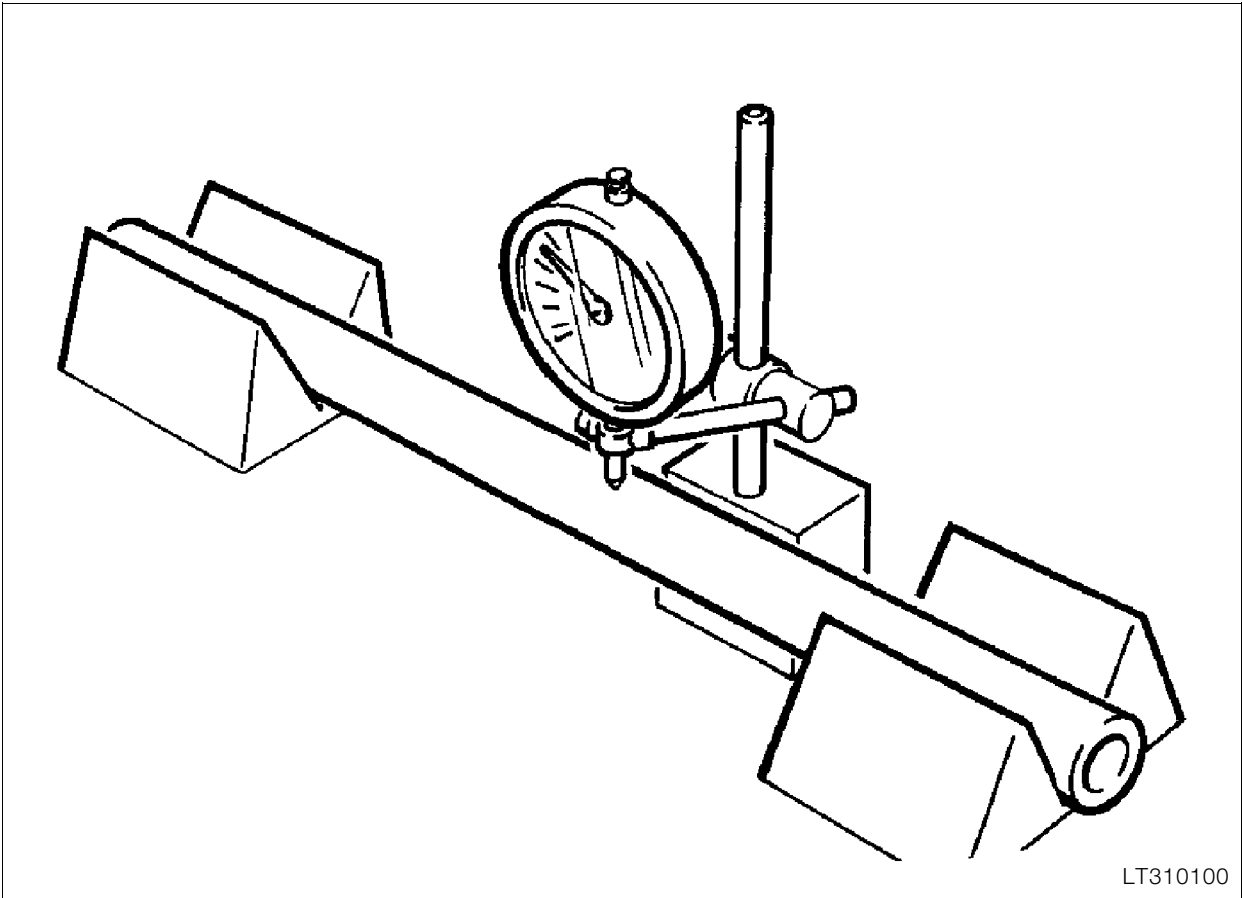

Checking runout of fixed tube

- Place both ends of stanchion in V-blocks.
- Slowly turn fixed tube while checking dial gauge.



Caution:

Distorted fixed tubes must not be straightened out!

Permissible runout 0.15 mm (0.0059 in)

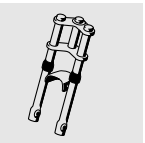

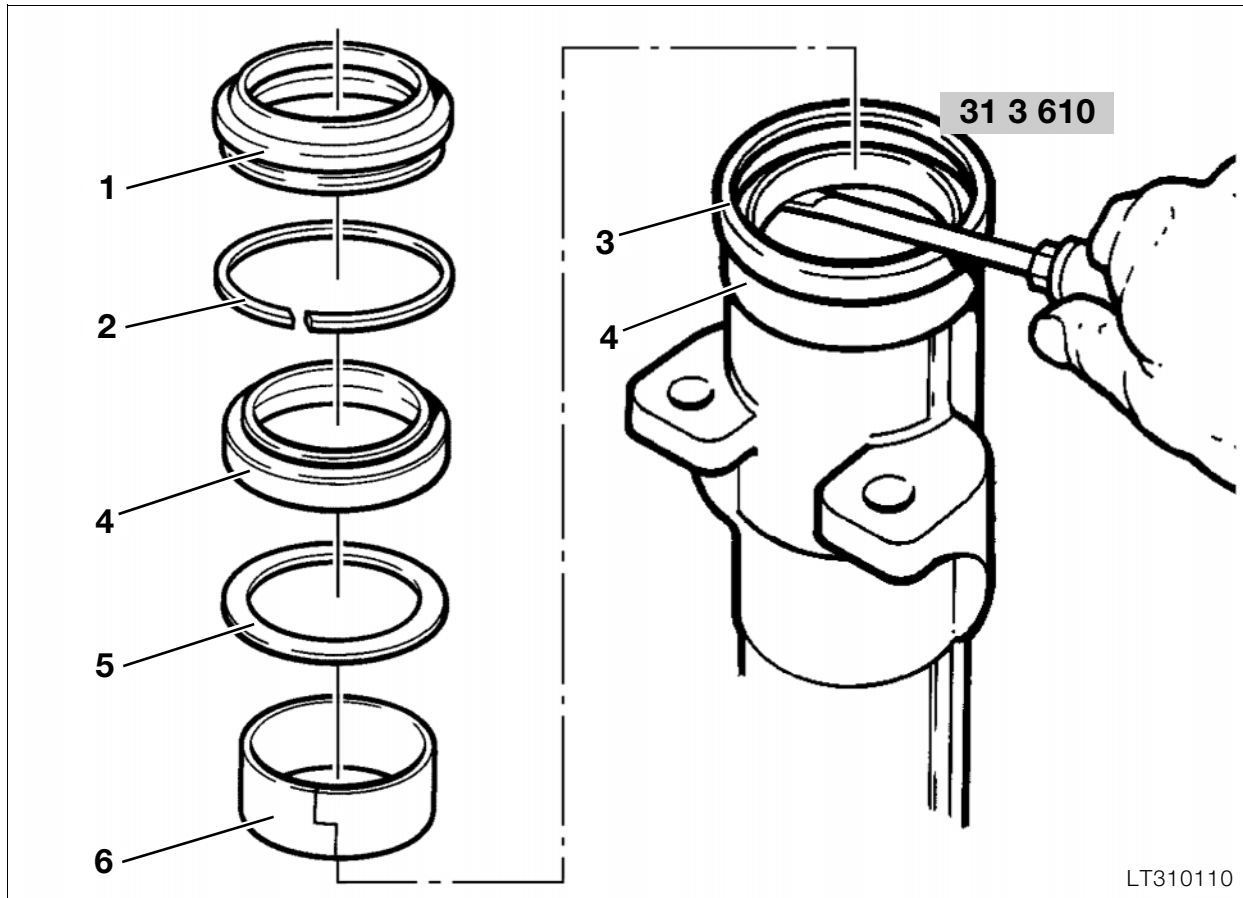

Disassembling telescopic fork

Removing fixed tube

- Loosen clamping screws at lower fork bridge.
- Remove fixed tube with slider tube from fork bridge.
- Drain oil.
- Clamp slider tube at mounting for brake caliper in vice with jaw guards.

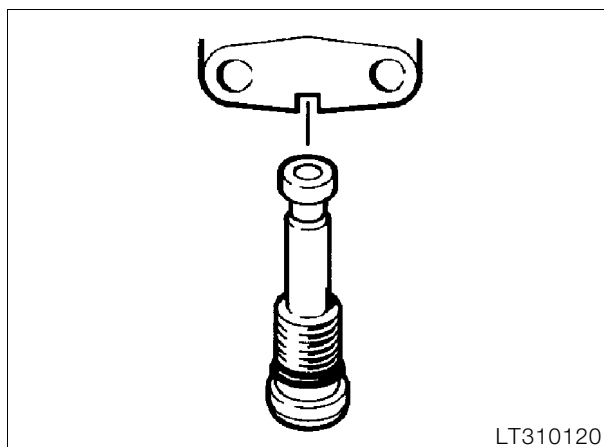

- Release bottom screw fitting and pull out fixed tube.

Disassembling slider tube

- Clamp slider tube at mounting for brake caliper vertically in vice with jaw guards.
- Using a blunt knife, lever out dust sleeve (1) from the outside.
- Using a small screwdriver, lever out retaining ring (2) for sealing ring.
- Fit support ring (3), **BMW No. 31 3 610**, on slider tube.
- Lever out shaft sealing ring (4) using a slightly rounded off screwdriver.
- Remove steel ring (5).
- Using both index fingers, remove plain bush (6) from slider tube.
- Check plain bush for damage/wear; replace if necessary.

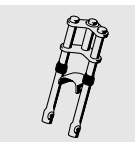

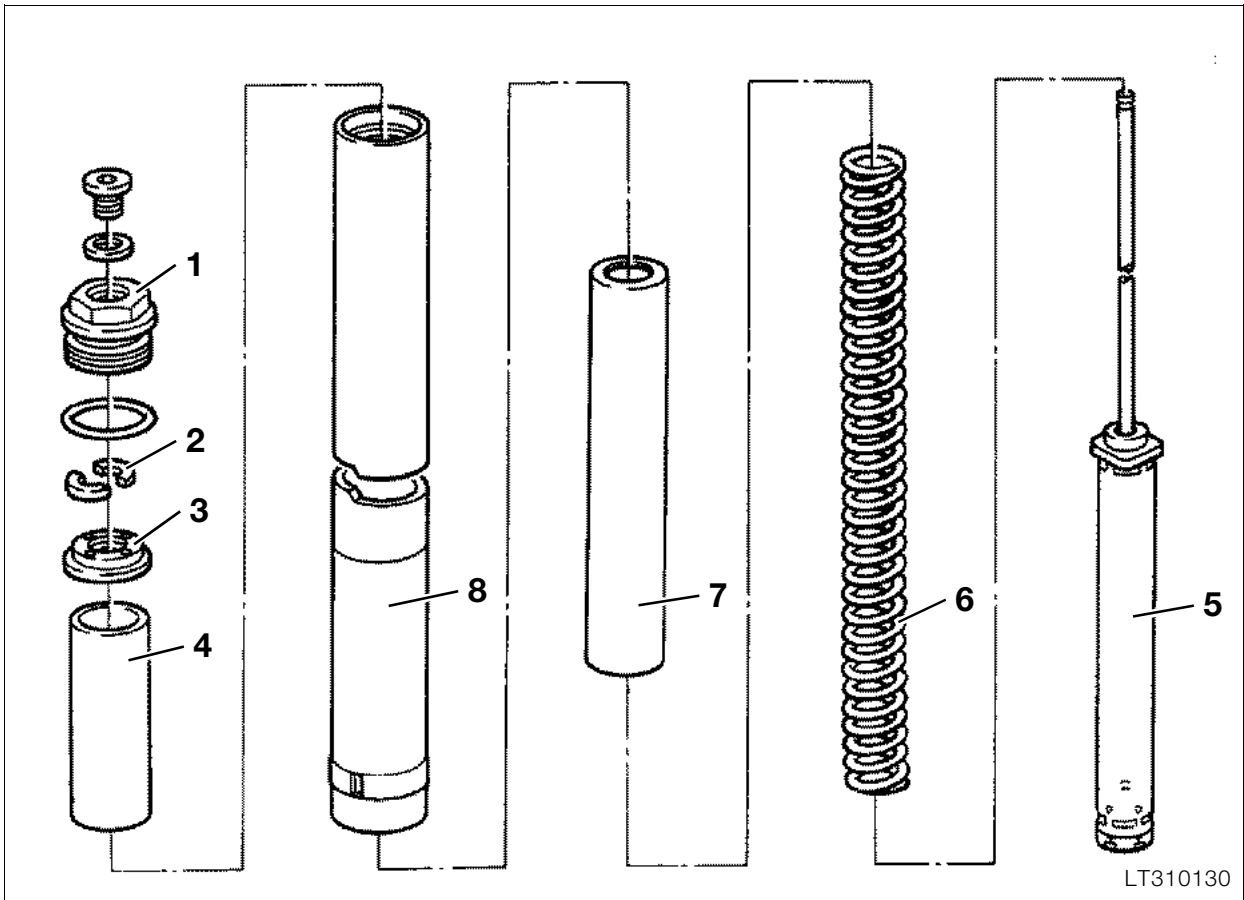

LT310130

Disassembling fixed tube

- Loosen screw plug (1) in fixed tube.

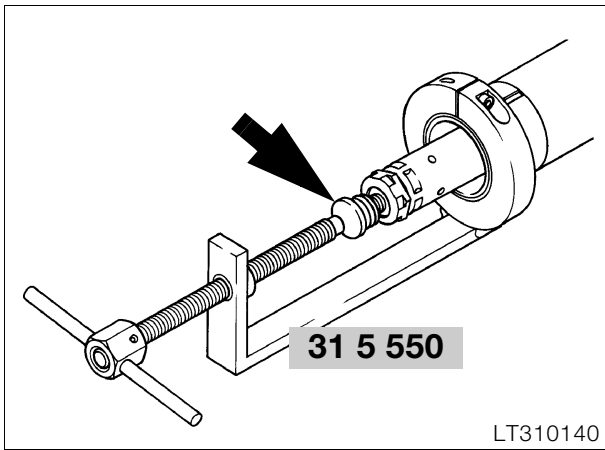

LT310140

- Screw base screw fitting (arrow) loosely into damper cartridge.
- Lightly press damper cartridge into fixed tube using clamping fixture, **BMW No. 31 5 550**, and clamping insert, **BMW No. 31 5 553**.

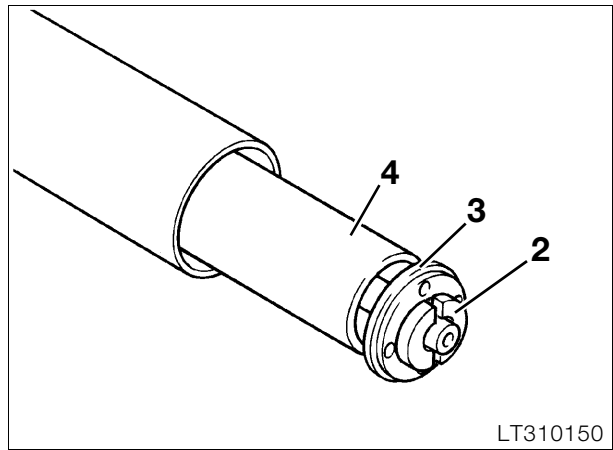

LT310150

- With the aid of a screwdriver, push apart retainers (2) on the piston rod.
- Remove perforated disc (3) and spacer (4).
- Remove damper cartridge (5) with support spring (6) and guide sleeve (7).

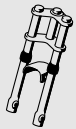

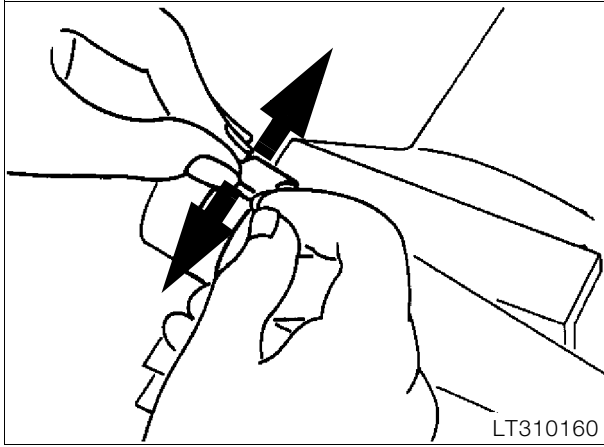

- Press apart plain bush (8) on the fixed tube (arrows) and remove.

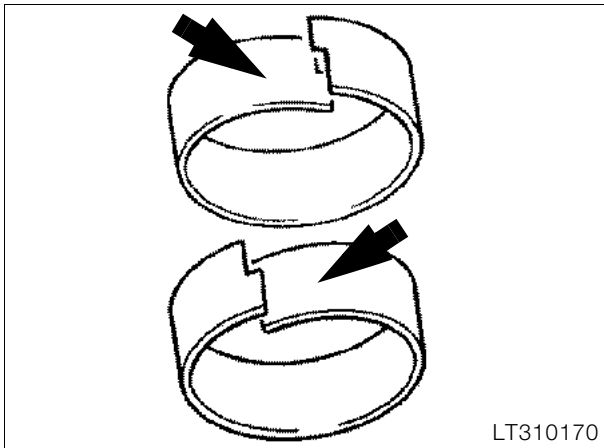

- Slightly preform new plain bush in order to achieve an optimum fit on the fixed tube.

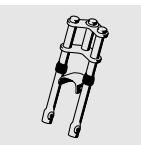

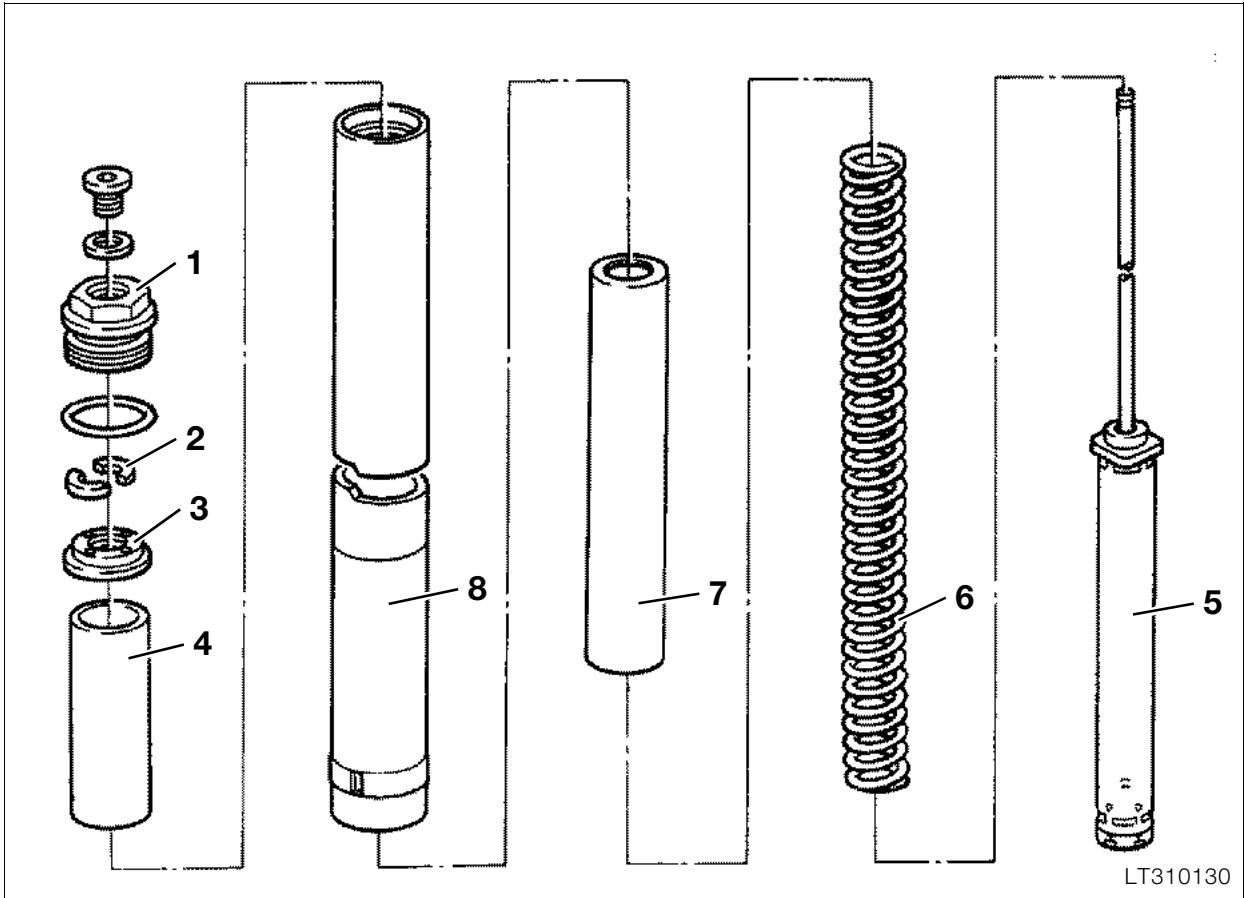

LT310130

Assembling telescopic fork

Assembling fixed tube

- Fit fork support spring (6) on damper cartridge (5), small winding spacing at top.
- Fit guide sleeve (7).
- Carefully clamp fixed tube (8) in vice with jaw guards.
- Slide complete damper cartridge into the fixed tube.

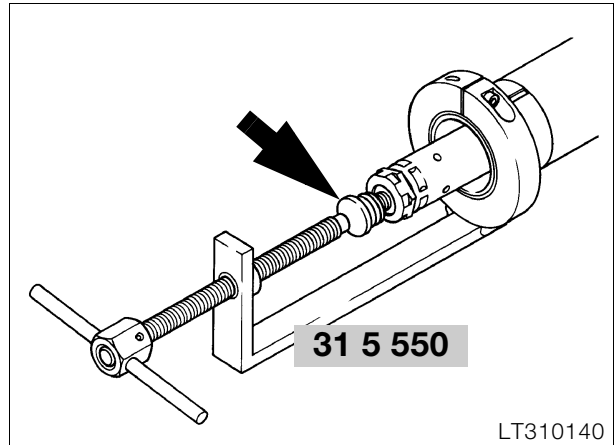

LT310140

- Loosely screw base screw fitting (arrow) into damper cartridge.
- With the aid of clamping fixture, **BMW No. 31 5 550**, and clamping insert, **BMW No. 31 5 553**, lightly press damper cartridge into fixed tube.

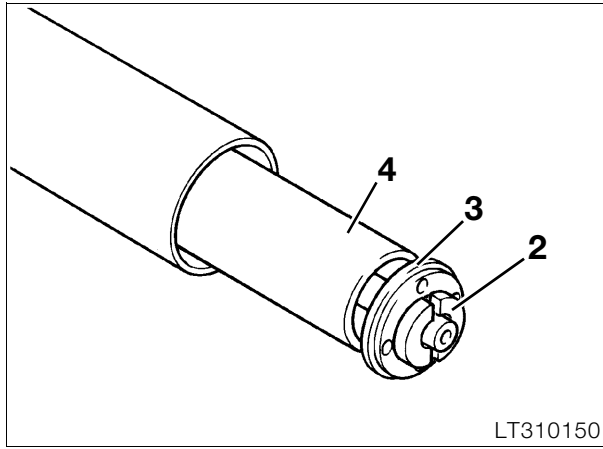

- Fit spacer sleeve (4).
- Fit perforated disc (3), smooth side facing downward.
- Fit retainers (2) and relieve clamping fixture.
- Screw in screw plug, renew seal if necessary.

 **Tightening torque:**
Base screw fitting 20 Nm

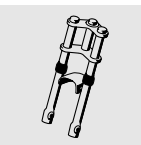

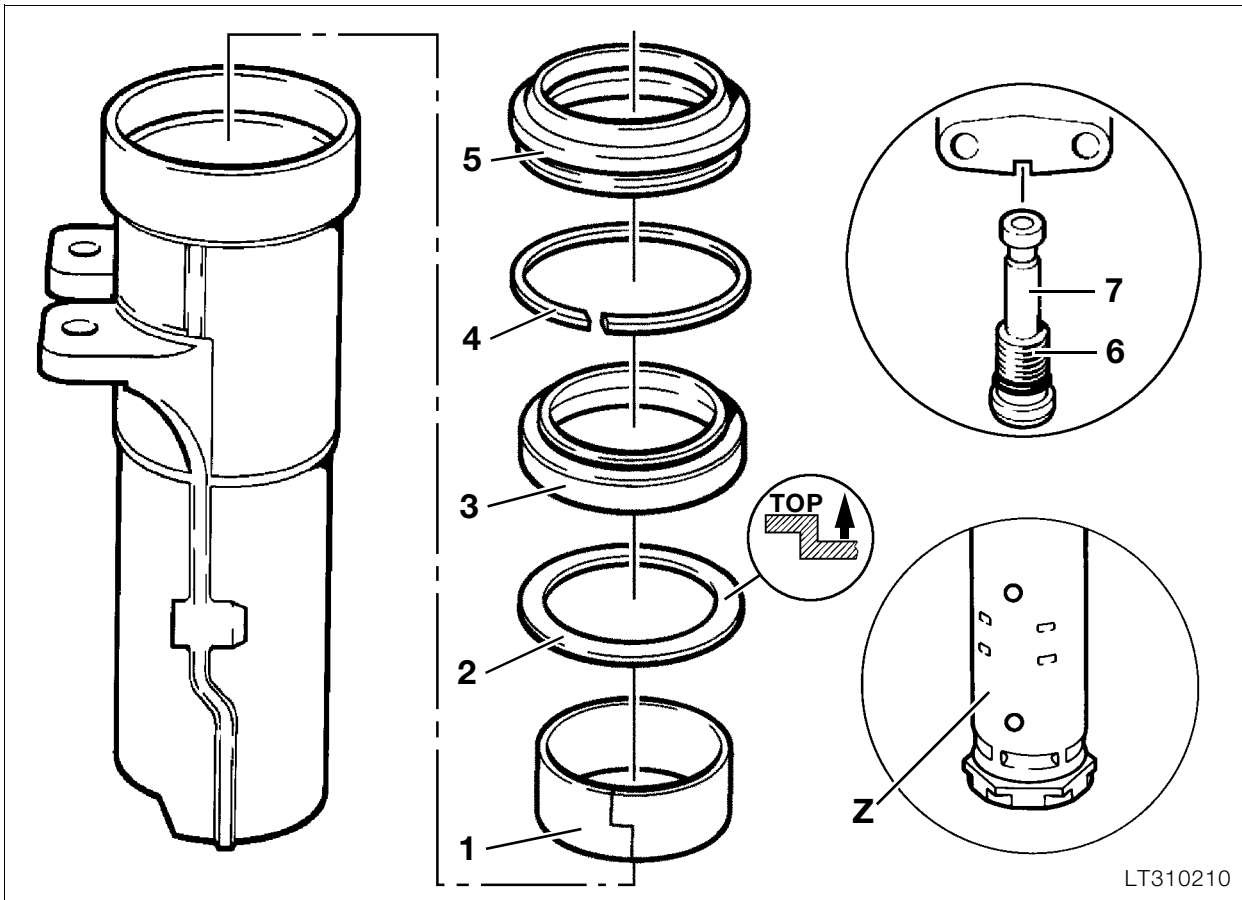

Assembling slider tube

- Install damper cartridge with hole pattern “Z” (tension stage) in the right-hand slider tube.
- Install plain bush (1) lubricated with fork oil.
- Slide fixed tube into slider tube.
- Screw together fixed tube and slider tube, if necessary use new sealing ring.



Tightening torques:

Base screw fitting 47 Nm

- Fit steel ring (2) in slider tube.
- Lightly oil radial sealing ring (3) with fork oil and slide from above over the fixed tube.

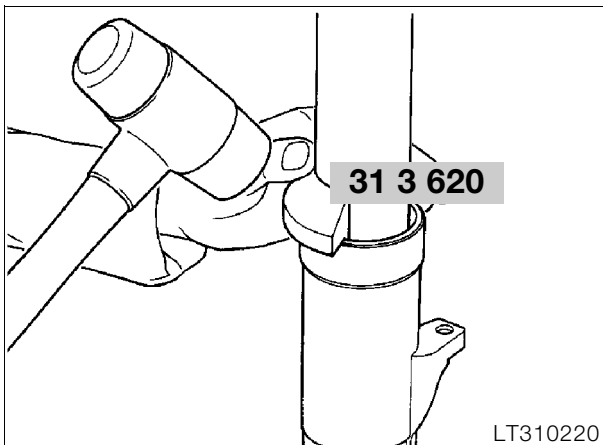

- Fit drift, **BMW No. 31 3 620**, on to fixed tube and release.



Note:

Prior to assembly, lightly coat radial sealing ring with tyre fitting paste.
Installation location: Large groove at bottom, labelling facing up.

- Fit retaining ring (4) in groove above the sealing ring.
- Fit dust gaiter (5) also with drift, **BMW No. 31 3 650**, dished side.



Note:

Pack grease pocket in the dust gaiter with, for example, **SHELL Retinax A** or **Gleitmo 805**.

Oil capacity:

Oil change:

left 0,35 - 0,01 l (0.616 - 0.0176 Imp. pt)

right 0,40 - 0,01 l (0.704 - 0.0176 Imp. pt)

New filling:

left, right 0,40 - 0,01 l (0.704 - 0.0176 Imp. pt)



Tightening torque:

Oil filler plug 10 Nm

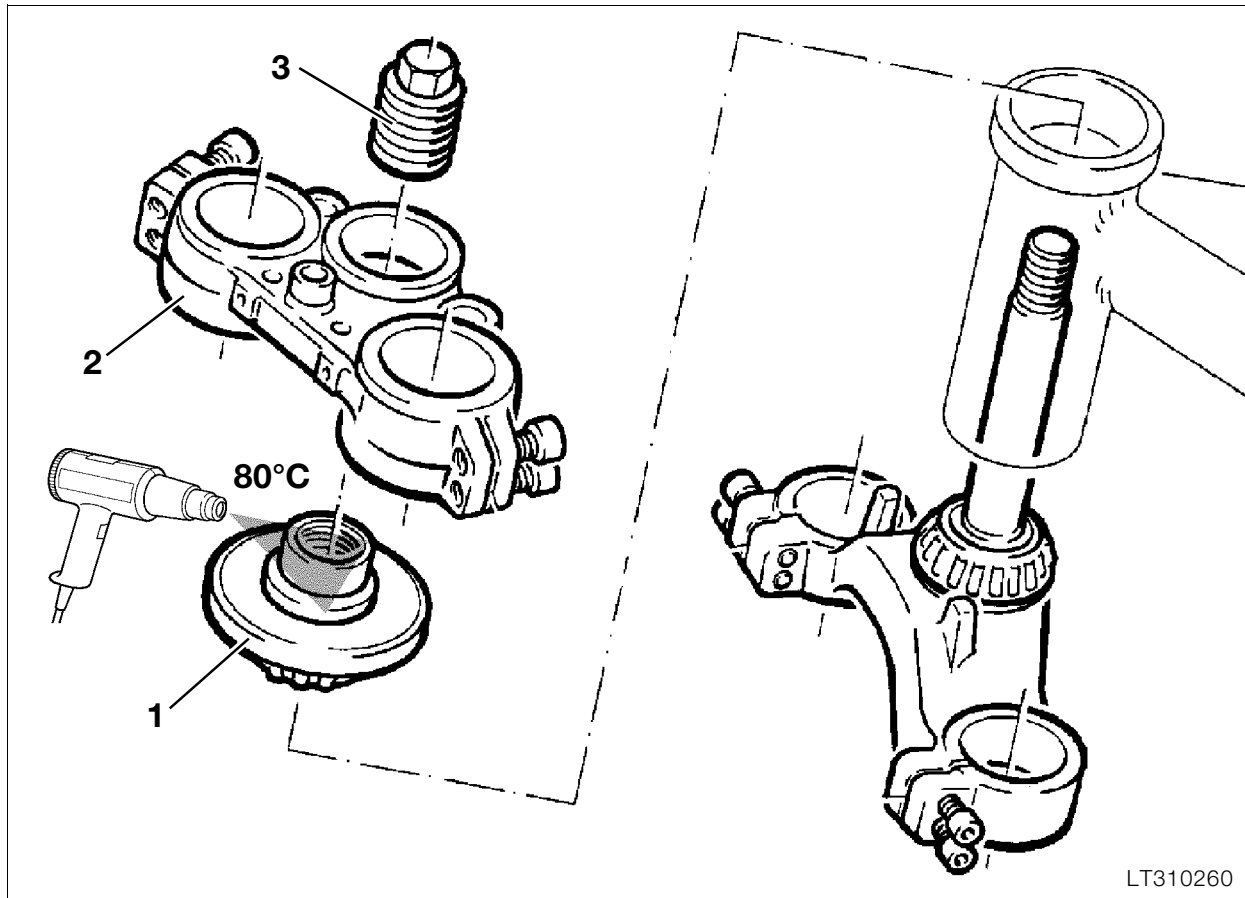

LT310260

Installing telescopic fork

- Grease taper roller bearing with **Shell "Retinax A"** or similar.
- Fit telescopic fork from below into steering head.
- Install setting ring (1), heat bearing 80 °C
- Install upper fork bridge (2).
- Screw in locking tube (3).



Note:

Do not firmly tighten clamping screws of the upper fork bridge at this stage.

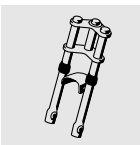

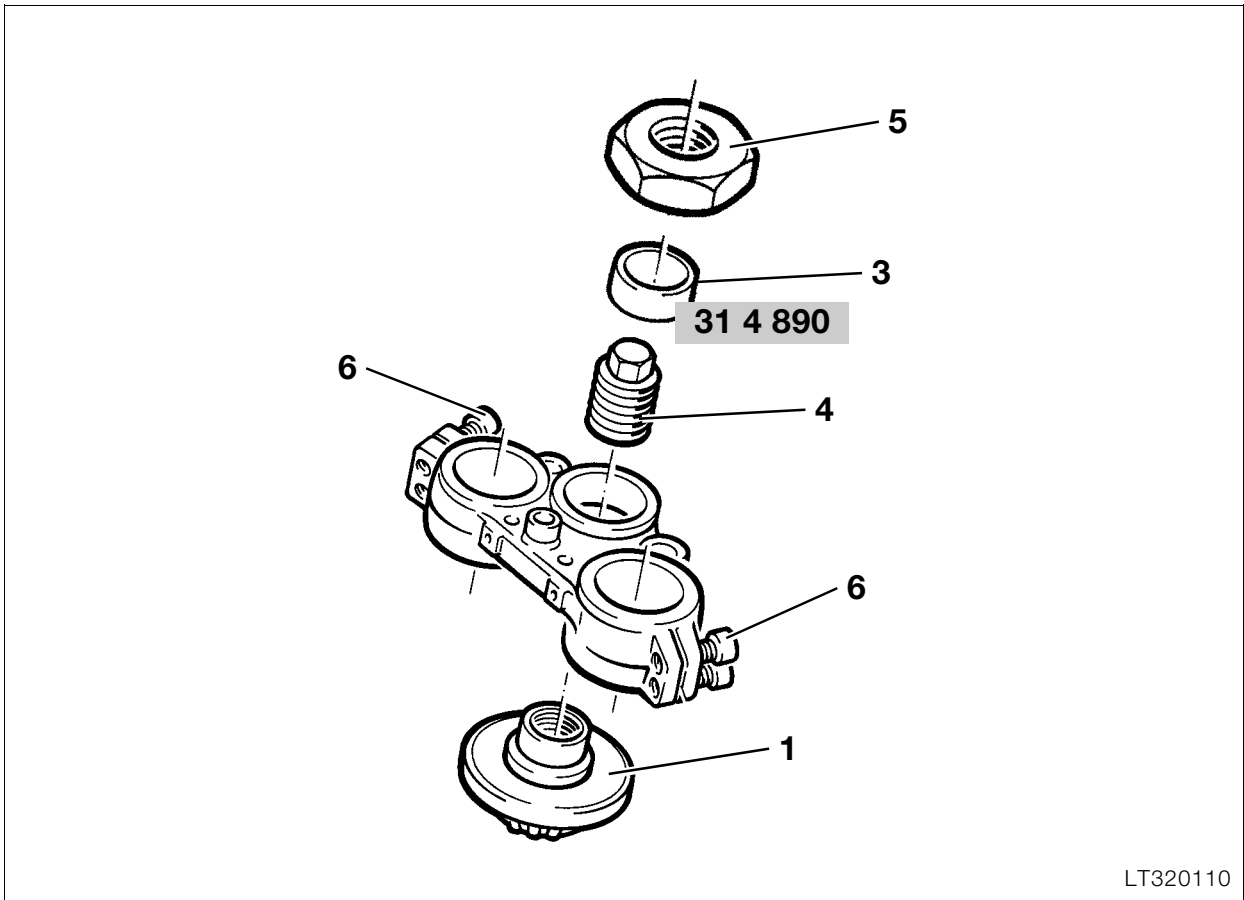

LT320110

Adjusting steering bearing play

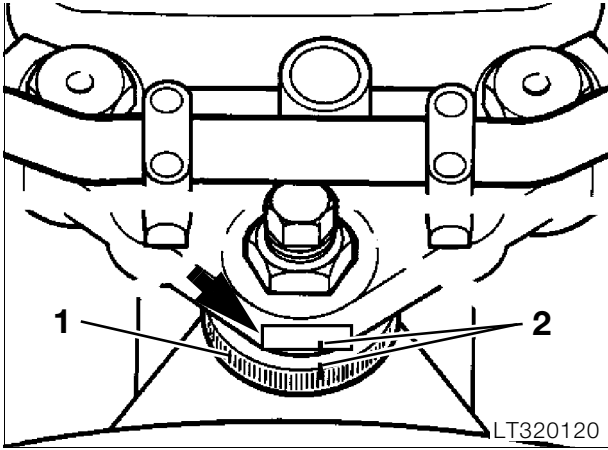

LT320120

- Fit a piece of adhesive tape (arrow) on the fork bridge above the setting ring.
- Mark current position of the setting ring (1) on the adhesive tape and on the setting ring (2).
- Fit thrust ring (3), **BMW No. 31 4 890**, over the locking tube (4).
- Lock thrust ring with hexagon nut (5) while holding the locking tube.
- With the aid of the hexagon nut, turn back the adjusting ring a little then tighten to the specified setting torque.

Setting torque:

Hexagon nut 12 Nm

New bearing:

Pretighten hexagon nut 25 Nm
 Move steering several times from lock to lock, loosen hexagon nut, retighten 12 Nm

- Mark new position of setting ring on adhesive tape.
- Release hexagon nut and remove thrust ring.
- Firmly tighten locking tube, tighten hexagon nut.



Note:

The position of the setting ring must no longer change!

- Firmly tighten clamping screws.
- Install handlebar.



Tightening torques:

Locking tube 65 Nm
 Hexagon nut 65 Nm
 Clamping screw of fork bridge (6)..... 15 Nm
 Clamping block for handle bar 22 Nm



Installing fork stabiliser

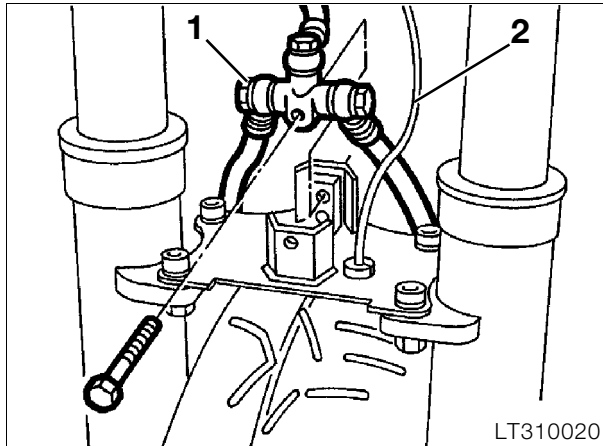

- Install fork stabiliser, handtighten screws.
- Install brake distributor (1).
- Lay ABS sensor line (2) and connect.
- Install fuel tank.
- Install front wheel.
- Install brake caliper.



Note:

Compress telescopic fork several times then firmly tighten fork stabiliser crosswise.



Tightening torque:

Fork stabiliser 22 Nm

- Install mudguard.

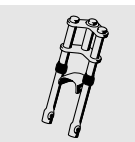

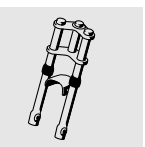

32 Steering

Contents

Page

Technical Data	3
Removing and installing left and right handlebar fittings	5
Removing and installing left handlebar fitting	5
Removing and installing handlebar weight	5
Removing and installing right handlebar fitting	7
Removing and installing handlebar	8
Removing and installing handlebar clamping blocks	9
Removing and installing accelerator cable	10
Removing and installing clutch cable	11
Removing and installing operating cable for increasing starting speed	12
Adjusting steering bearing play	13



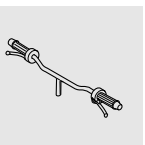

Technical Data	K 1100 LT	K 1100 RS
Steering angle	° 2 x 34	
Steering tube-∅	mm (in) 22 (0.86614)	
Handlebar width with weights	mm (in) 765 (30.11805)	700 (27.559)

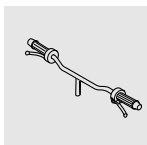

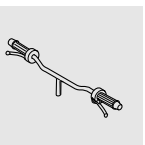

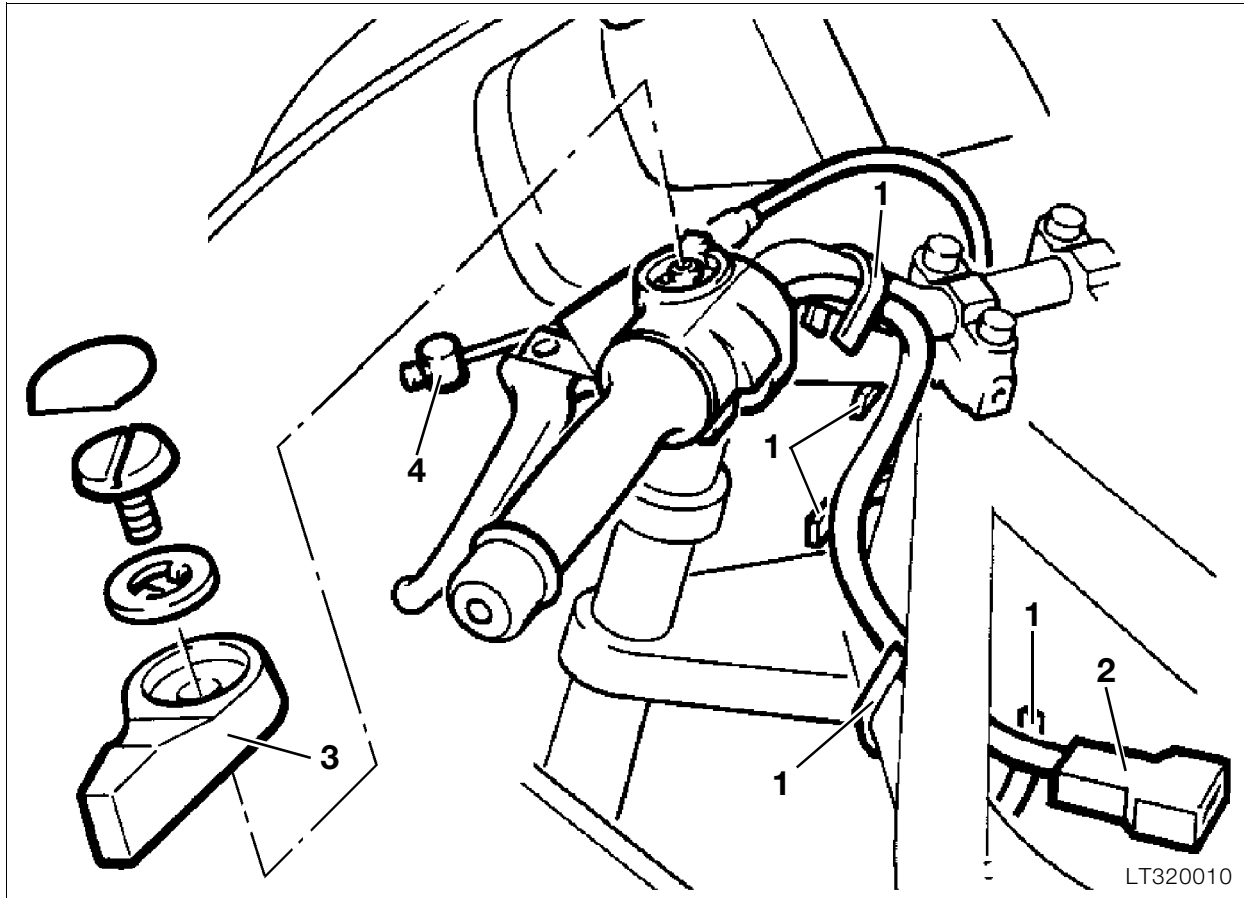

LT320010

Removing and installing left and right handlebar fittings

Removing and installing left handlebar fitting

- Remove fuel tank.
- **[LT]** Cut through cable clip (1)
- Disconnect plug connection for clutch switch (2).
- Detach cold start operating cable at lever (3).
- Detach clutch cable (4) at clutch release lever, then at handlebar lever.

Removing and installing handlebar weight

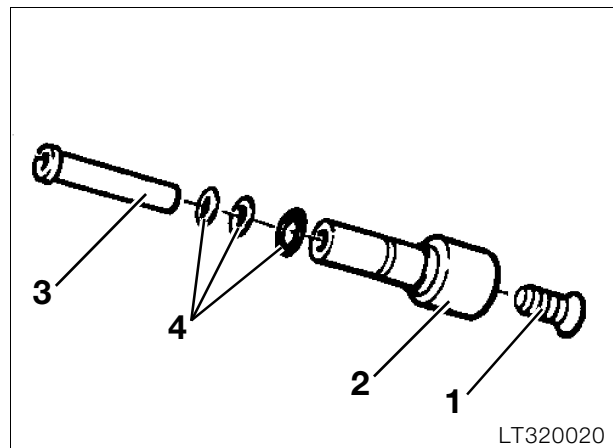

LT320020

- Release countersunk screw (1)
- Pull out handlebar weight (2).
- Pull out threaded sleeve (3) with screw.
- Note O-ring (4).



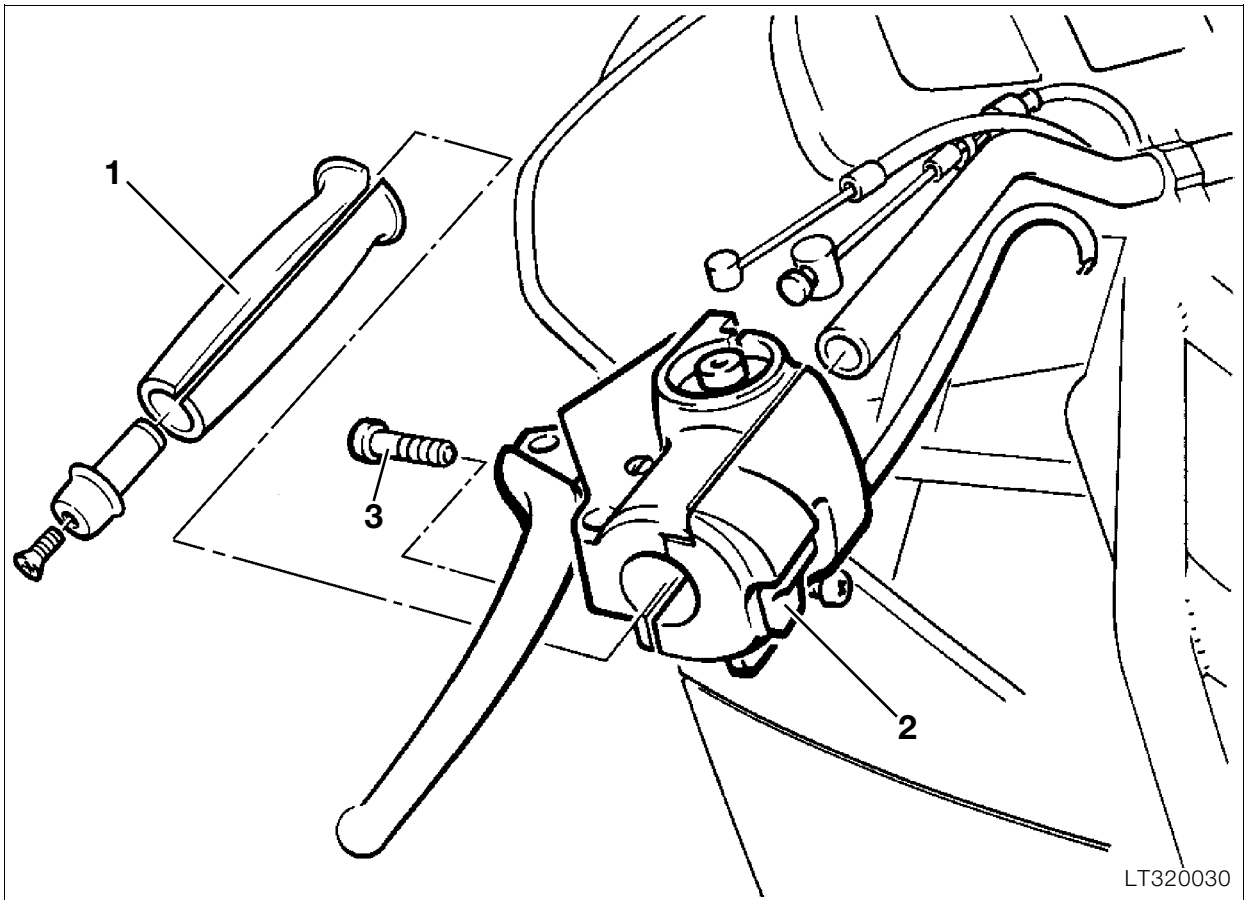

- Cut open rubber grip (1) and remove.
- Release multifunction switch (2).
- Loosen clamping screw (3) of handlebar fitting.
- Remove fitting from handlebar.
- Install in the reverse order of removal.



Note:

Bond rubber grip with **Loctite 454** on handlebar.



Tightening torque:

Clamping screw, handlebar fitting 5 Nm

Settings:

Clutch play at handlebar lever 4 ± 0.5 mm
 (0.15748 \pm 0.0197 in)

Cable length at clutch release lever 75 ± 1 mm
 (2.95275 \pm 0.0394 in)

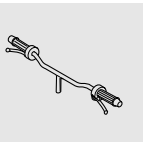

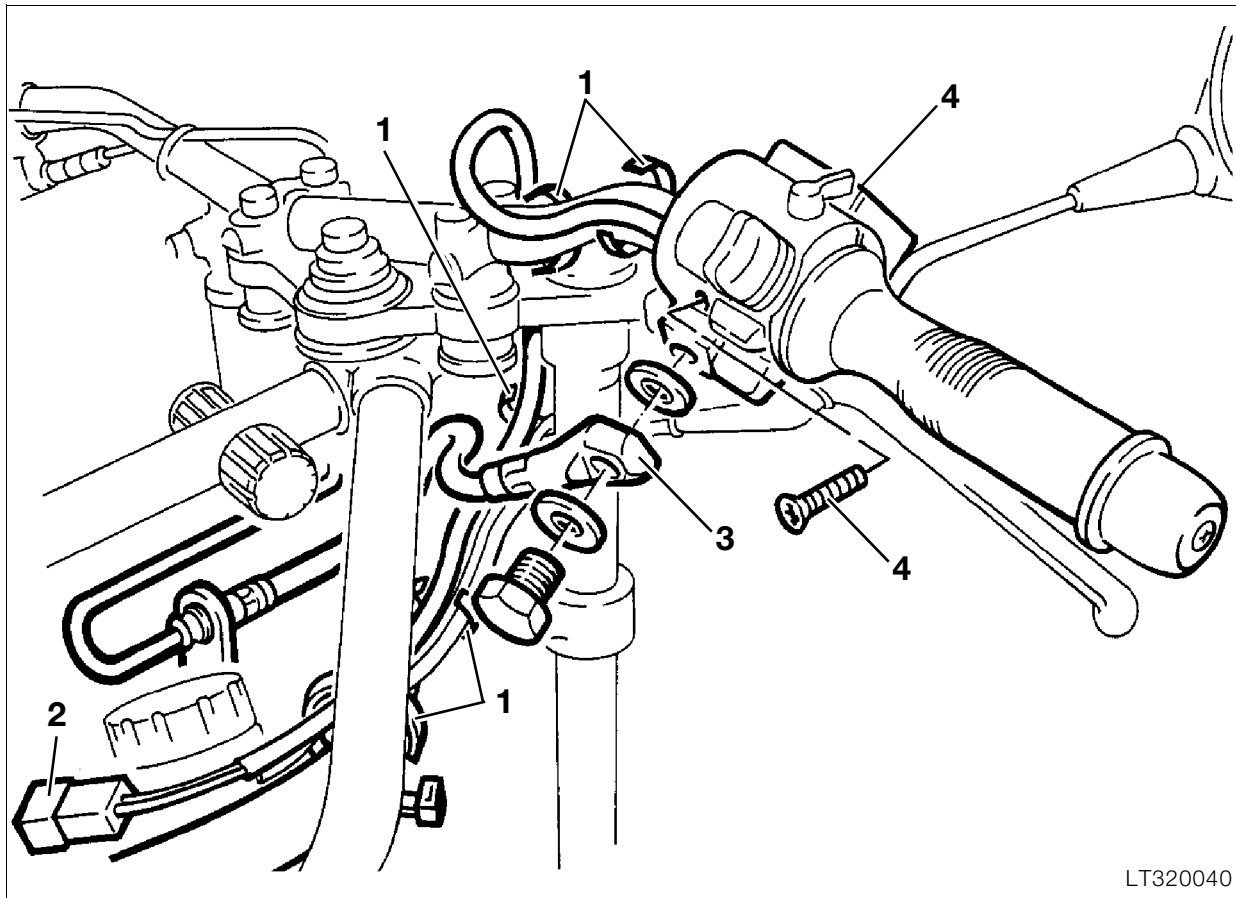

LT320040

Removing and installing right handlebar fitting

- Remove fuel tank.
- **[LT]** Cut through cable clip (1).
- Disconnect plug connection (2) for brake light switch.
- Release brake line (3) and close off.
- Release multifunction switch (4).

- Remove fitting.
- Cut through rubber grip and remove.
- Install in the reverse order of removal.



Caution:

Top up brake fluid, vent system!



Note:

Turn connection piece (3) of the brake line such that the brake line does not chafe at any point when the handlebar is turned.

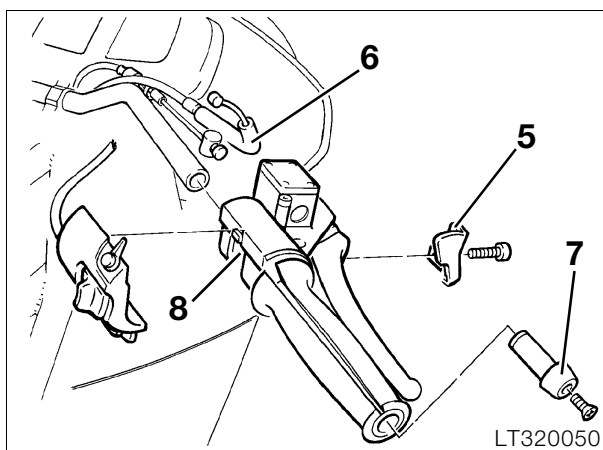

LT320050

- Loosen cover (5) for accelerator cable.
- Detach accelerator cable (6).
- Remove handlebar weight (7).
- Loosen clamping screw (8) from fitting housing.



Tightening torques:

Brake line	7 Nm
Bleed screw	7 Nm
Clamping screw	5 Nm

Setting:

Accelerator cable play..... 0.75 mm (0.0295 in)

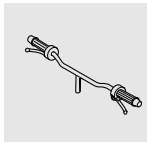

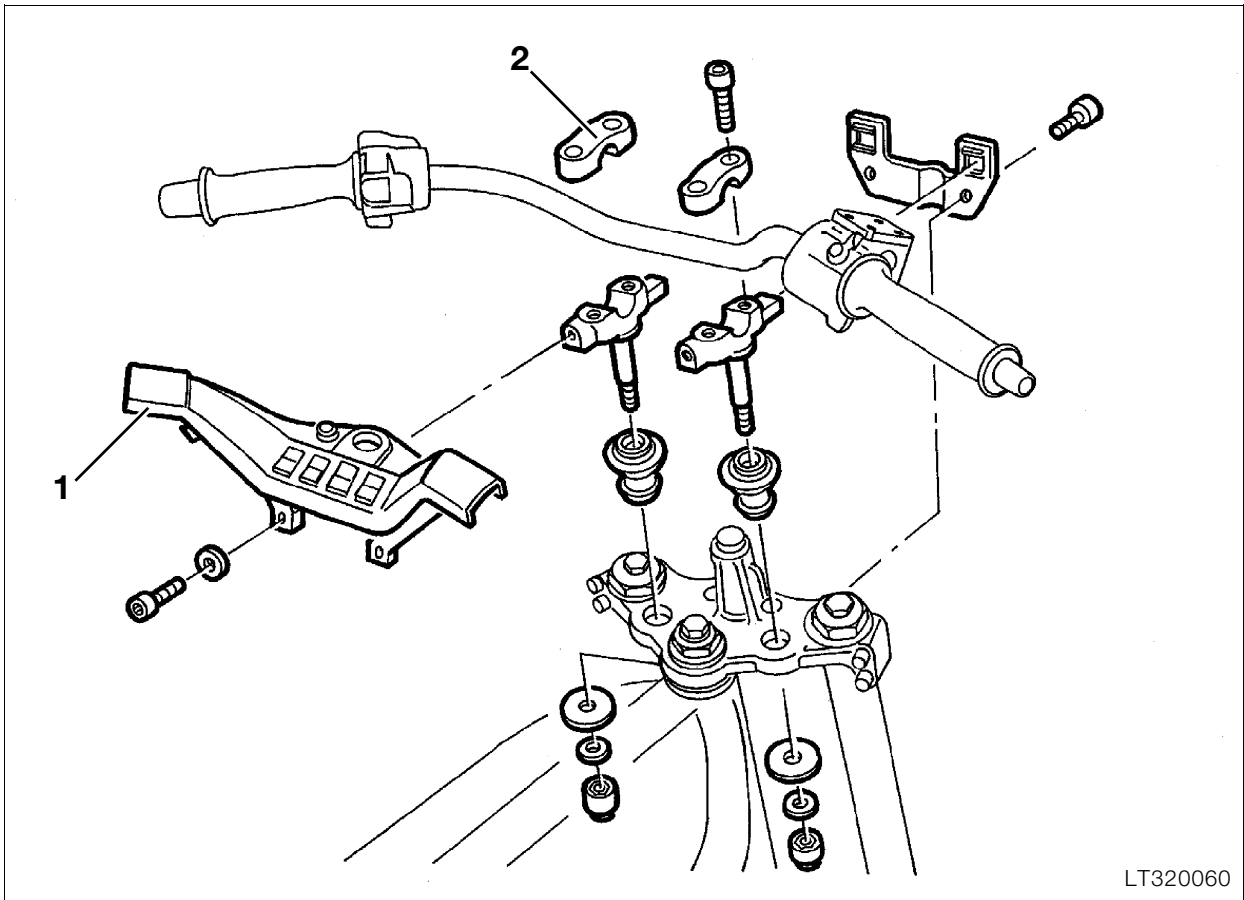

LT320060

Removing and installing handlebar

- Remove fuel tank.
- Remove handlebar cover (1).
- Disconnect plug connections for switches.
- Remove left and right handlebar fittings.
- Release top sections of clamping block (2).
- Install in the reverse order of removal.

 **Tightening torque:**
 Clamping screws..... 22 Nm

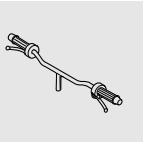

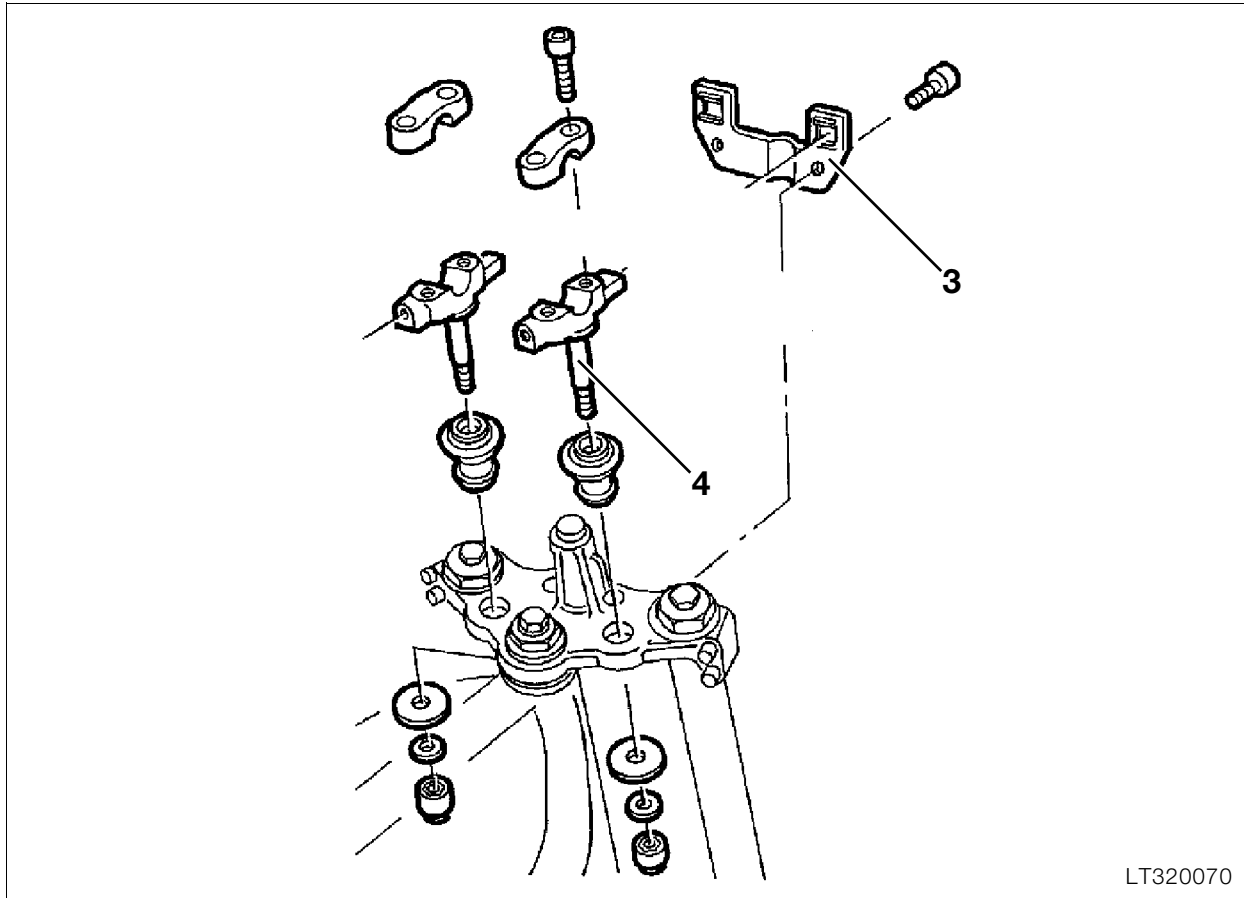

LT320070

Removing and installing handlebar clamping blocks

- Remove stop plate (3).
- Remove clamping blocks (4).
- Drive out handlebar mounting with drift.
- Install in the reverse order of removal.

 **Tightening torque:**
 Clamping block 16 Nm

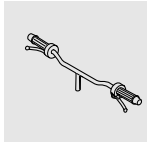

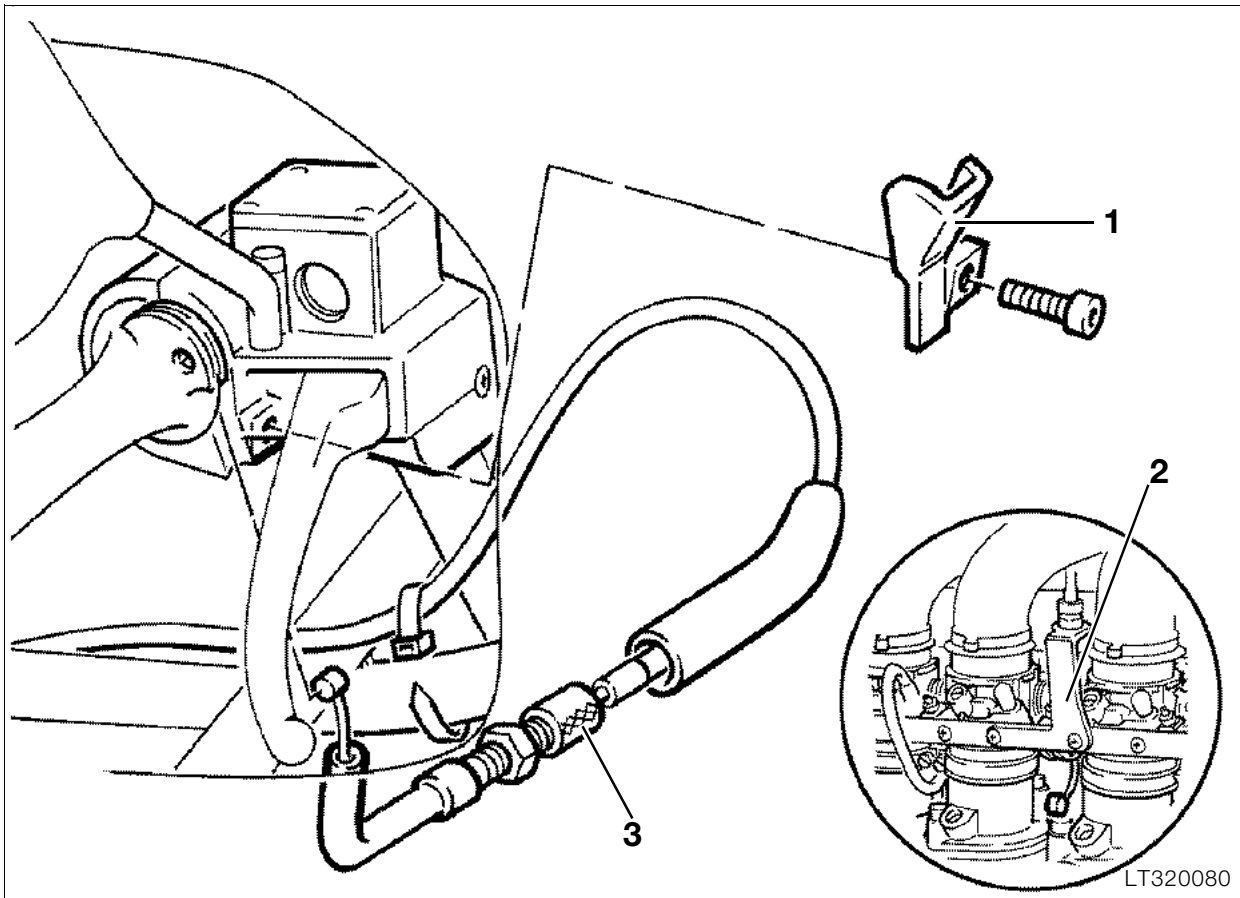

Removing and installing accelerator cable

- Remove fuel tank.
- Remove cable cover (1) on handlebar fitting.
- Detach cable.
- Turn in cam disc on throttle stub pipe (2) and detach cable.
- Install in the reverse order of removal.



Note:

When installing, first attach cable at cam disc. Fit cable without kinks.

- Adjust cable play at adjusting screw (3).

Accelerator cable play:

Desired value 0.75 mm (0.0295 in)

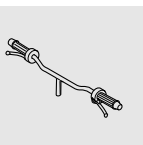

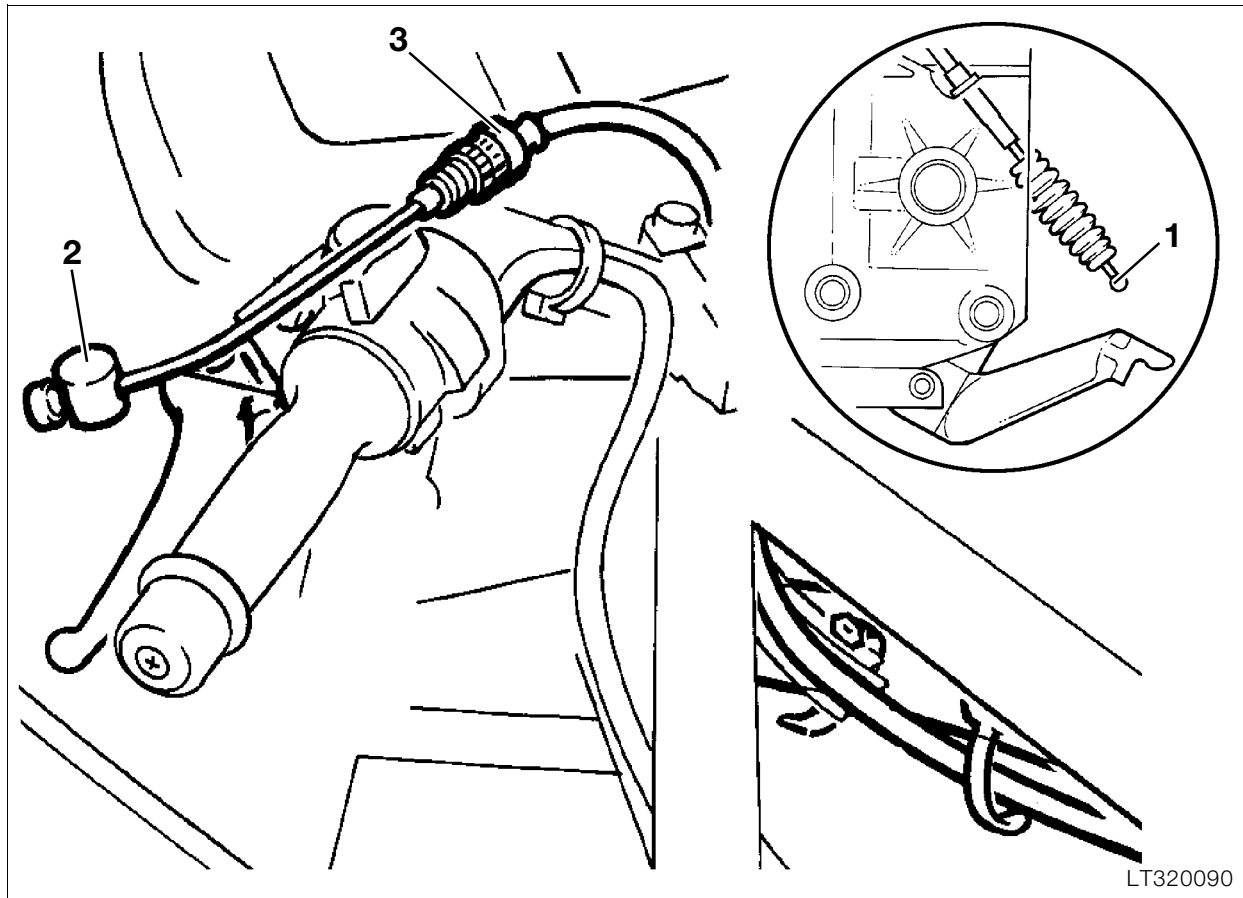

Removing and installing clutch cable

- Remove fuel tank.
- Detach clutch cable (1) at clutch release lever.
- Pull clutch hand lever and press out nipple (2).
- Unscrew set screw (3) from fitting housing.
- Cut through cable clip and pull out operating cable.
- Install in the reverse order of removal.



Note:

Ensure the operating cable is fitted correctly, with no kinks.

- Adjust cable after fitting.

Settings:

Play at handlebar lever $4 \pm 0,5$ mm
 (0.15748 \pm 0.0197 in)
 Cable length at clutch release lever 75 ± 1 mm
 (2.95275 \pm 0.0394 in)

Adjusting instructions:

See Group 00, "Checking clutch operating clearance, adjusting if necessary".



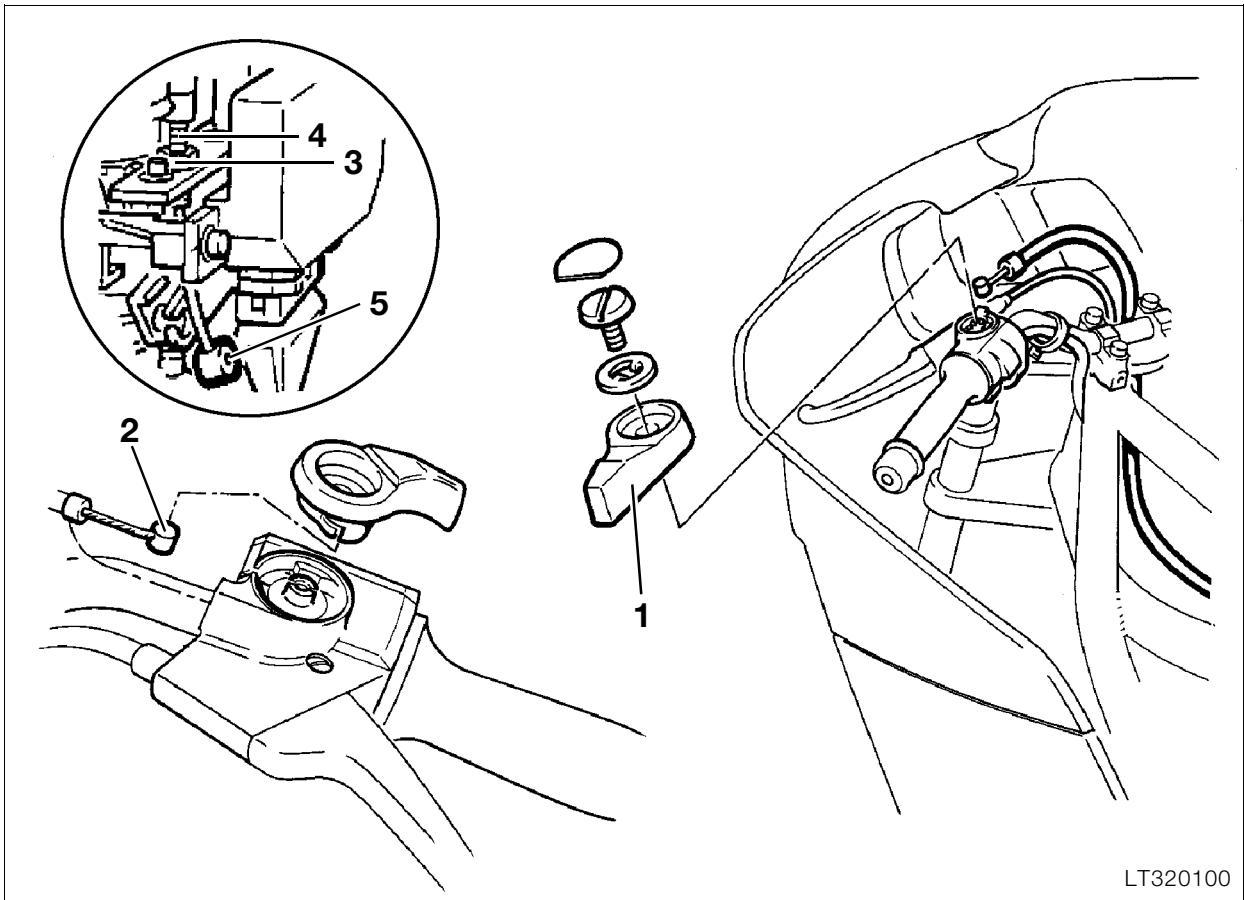

Removing and installing operating cable for increasing starting speed

- Remove fuel tank.
- Remove operating lever (1).
- Detach cable (2).
- On throttle rail, release locknut (3) from adjusting screw (4) and unscrew adjusting screw.
- Detach nipple (5).
- Remove cable by pulling from below.
- Install in the reverse order of removal.



Note:

Fit cable without kinks. Check setting of start speed increase.

Adjusting instructions:

See Group 00, "Checking clutch operating clearance, adjusting if necessary".

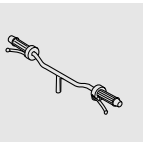

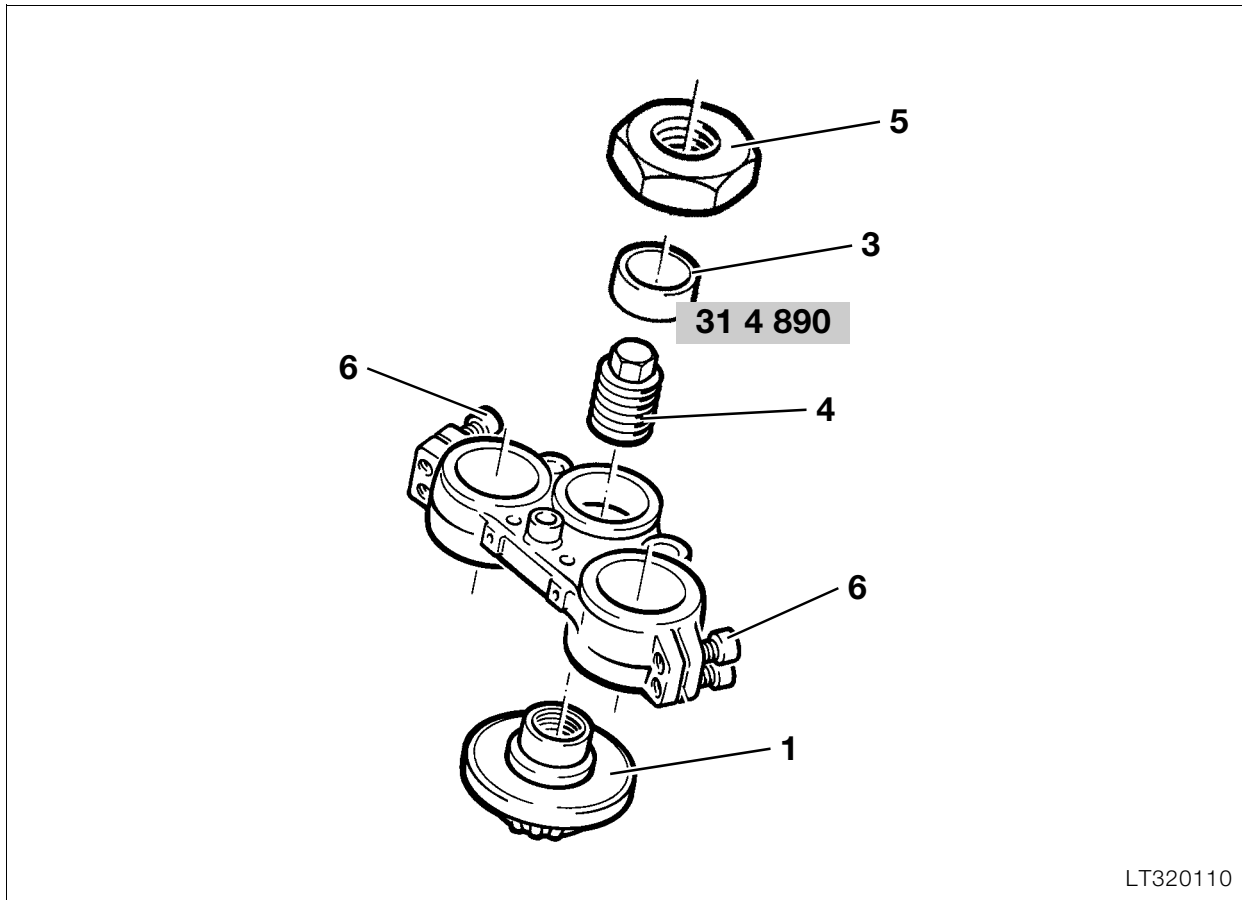

LT320110

Adjusting steering bearing play

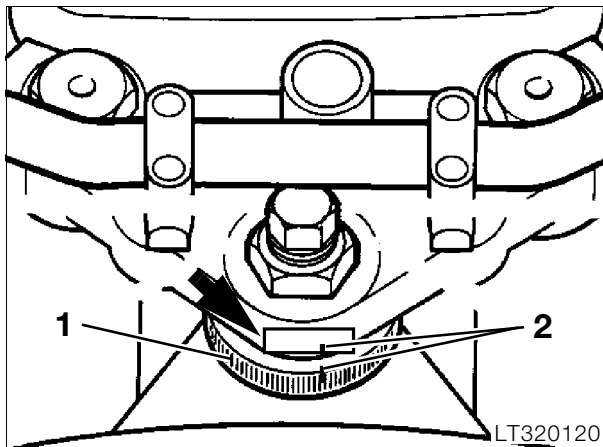

LT320120

- Fit a piece of adhesive tape (arrow) on the fork bridge above the setting ring.
- Mark current position of setting ring (1) on adhesive tape and on setting ring (2).
- Slide thrust ring (3), **BMW No. 31 4 890**, over the locking tube (4).
- Lock thrust ring with hexagon nut (5) while holding the locking tube.
- Using the hexagon nut, turn back the setting ring a little then tighten to the specified setting torque.

Setting torque:

Hexagon nut 12 Nm

Setting torque for new bearing:

Pretighten hexagon nut to 25 Nm
 Move steering from lock to lock several times,
 loosen hexagon nut and retighten 12 Nm

- Mark new position of setting ring on adhesive tape.
- Release hexagon nut and remove thrust ring.
- Firmly tighten locking tube, tighten hexagon nut.



Note:

The position of the setting ring must now no longer be changed!

Tighten clamping screws.
 Install handlebar.



Tightening torque:

Locking tube 65 Nm
 Hexagon nut 65 Nm
 Clamping screws of fork bridge 15 Nm
 Clamping block for handlebar 22 Nm



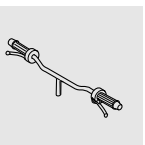

33 Rear wheel drive

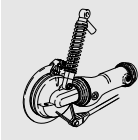

Contents

Page

Technical data	3
Removing, disassembling, assembling and installing rear wheel drive	5
Removing rear wheel drive	5
Removing, disassembling and assembling drive bevel gear	5
Removing retaining ring	5
Disassembling drive bevel gear	7
Removing needle bearing for drive bevel gear	8
Installing needle bearing for drive bevel gear	8
Assembling drive bevel gear	9
Installing drive bevel gear	10
Removing and installing taper needle bearing in rear wheel drive	11
Removing crown wheel	12
Installing crown wheel	13
Checking/adjusting tooth backlash	14
Checking contact pattern	15
Shimming housing cover	16
Installing housing cover	16
Installing slider	16
Installing rear wheel drive	17
Removing, disassembling and assembling rear swinging arm	19
Removing and installing taper roller bearing	19
Removing and installing gaiter	20
Removing drive shaft	20
Checking universal joint for wear	20
Removing retaining ring	20
Installing drive shaft	20
Installing swinging arm	21
Installing footrest plates	21

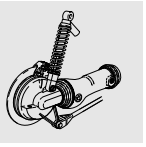

Technical data	K 1100 LT	K 1100 RS
Rear wheel drive		
Type of gearing	Klingelnberg Palloid spiral bevel	
Number of teeth	32 : 11	
Gear ratio	2.91 : 1	
Tooth backlash	mm (in)	0.07 ...0.16 (0.00276...0.006299)
Taper roller bearing preload	mm (in)	0.05...0.1 (0.01969...0.003937)
Oil grades	Brand-name hypoid gear oil, API class GL 5	
Content	l (Imp.pt)	
Initial filling		0.25 (0.44)
Oil change		0.23 (0.4048)
Viscosity class at outside temperature		
above 5 °C		SAE 90
below 5 °C		SAE 80
all year		SAE 80 W 90
Drive shaft		
Arrangement	Encapsulated in the one-arm swinging fork (BMW PARALEVER), 2-piece double drive shaft with integrated torsion damper, universal joints on both ends, slide piece on axle drive end.	
Rear wheel suspension		
Spring strut	Gas-filled spring strut, four adjustment settings, with travel-dependent damping and progressive spring rate	
Spring travel	mm (in)	120 (4.42744)



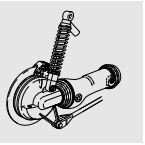

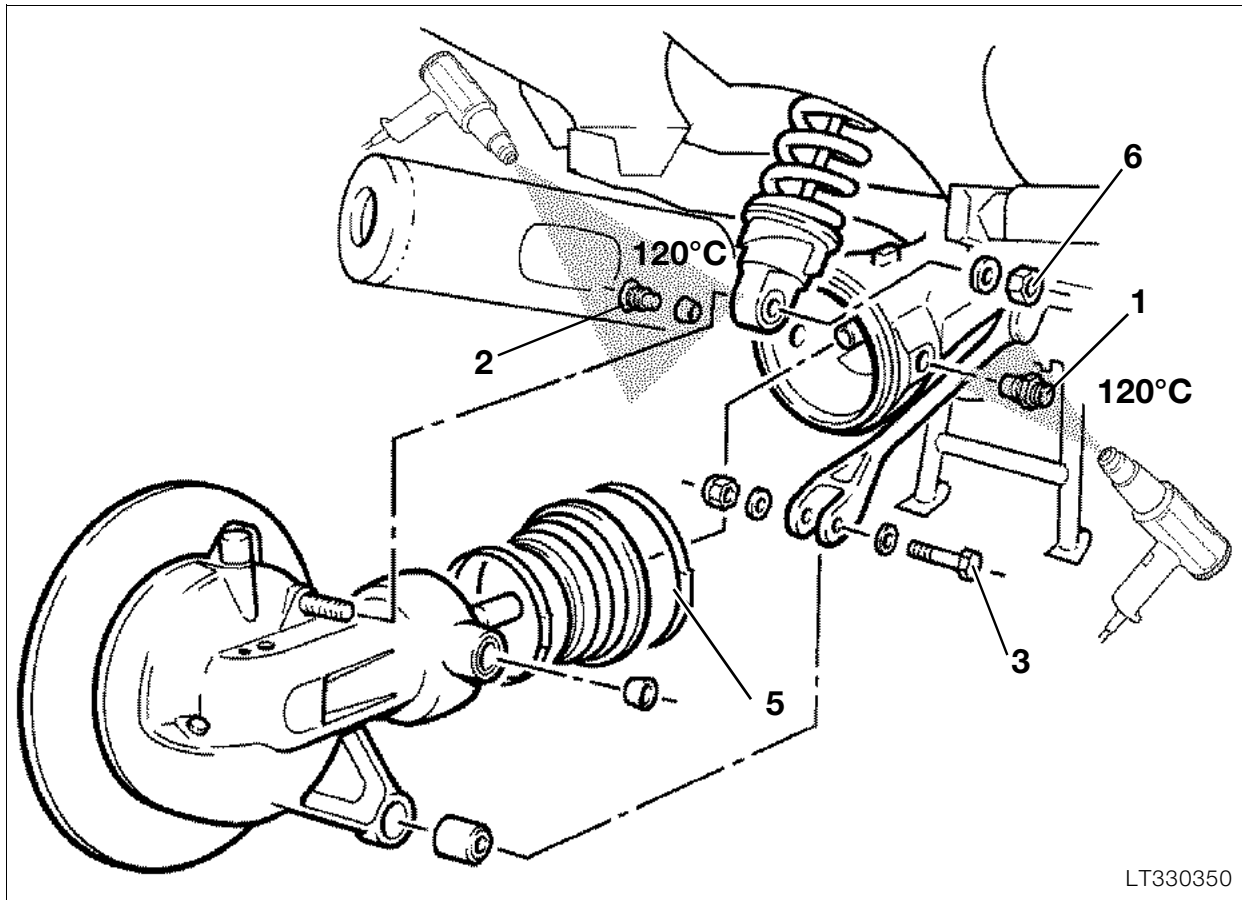

LT330350

Removing, disassembling, assembling and installing rear wheel drive

- Remove licence plate bracket.
- Remove rear wheel.
- Remove brake disc, mark position with **ABS**.

Removing rear wheel drive

- Remove speedometer drive.
- Heat free bearing journal (1) to max. 120 °C and loosen it; heat fixed bearing journal (2) to max. 120 °C and loosen it.
- Release free bearing journal and fixed bearing journal



Note:

Note the inner races of the needle bearings.

- Release clamping band?(5).
- Loosen strut on rear wheel drive?(3).
- Release spring strut at rear wheel drive (6) and remove from stud bolt by pulling to the side.
- Disconnect rear wheel drive from drive shaft.



Note:

When the rear wheel drive is filled with oil, never place it on its side prior to installation otherwise oil will escape to the drive gear (suction effect).

Removing, disassembling and assembling drive bevel gear

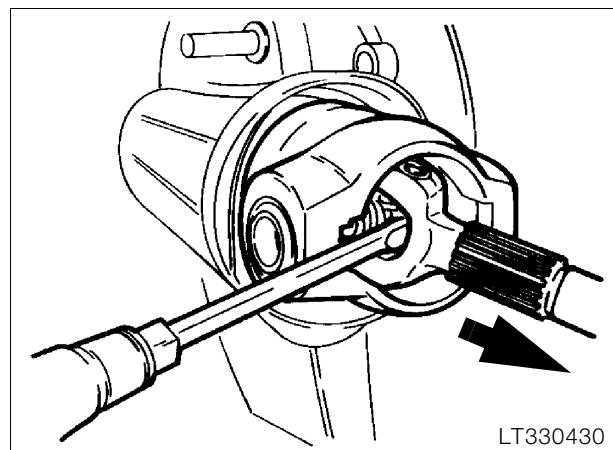

LT330430

- Press out disc piece.
- Drain oil.

Removing retaining ring

- With the aid of a small screwdriver, lever out retaining ring in universal joint.
- Install in the reverse order of removal.

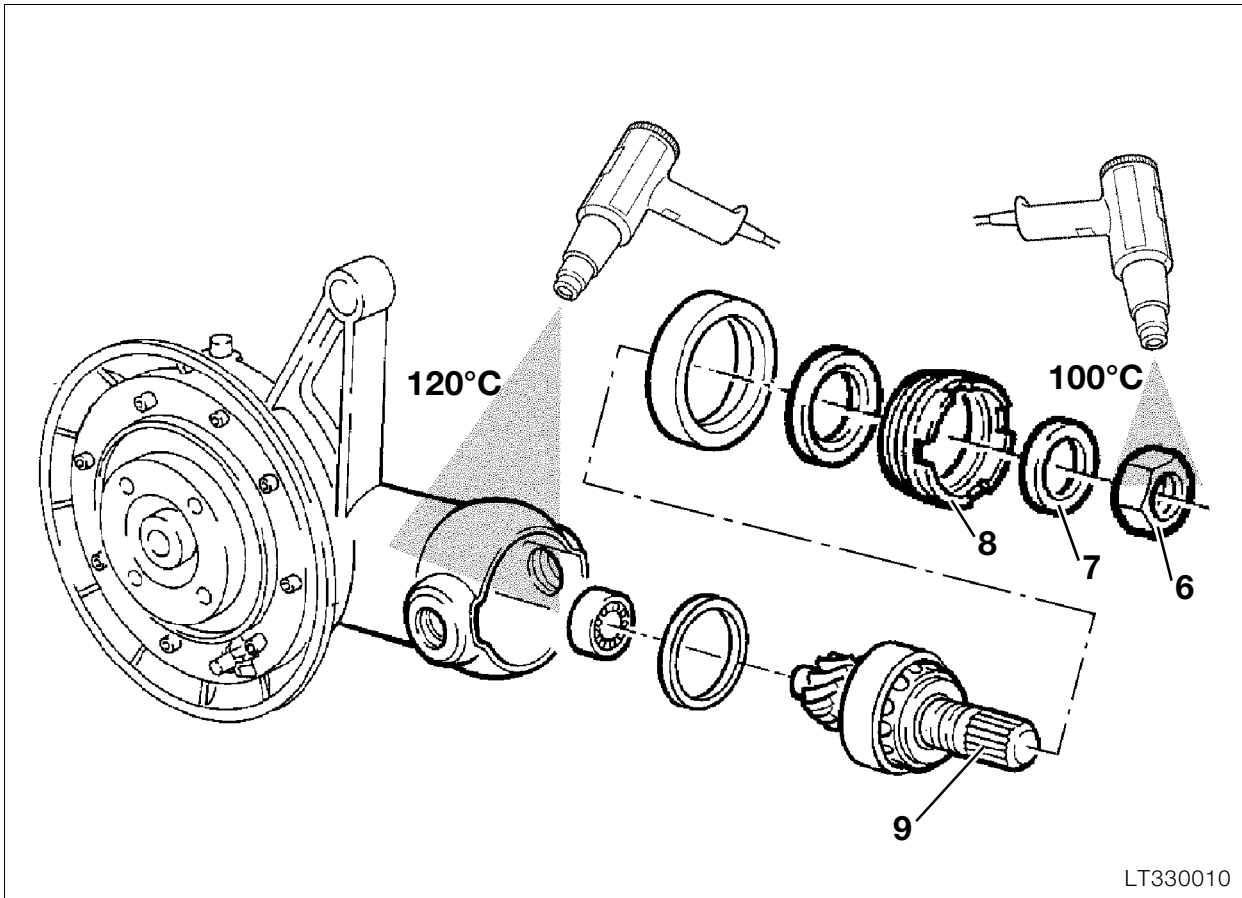
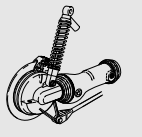

LT330010

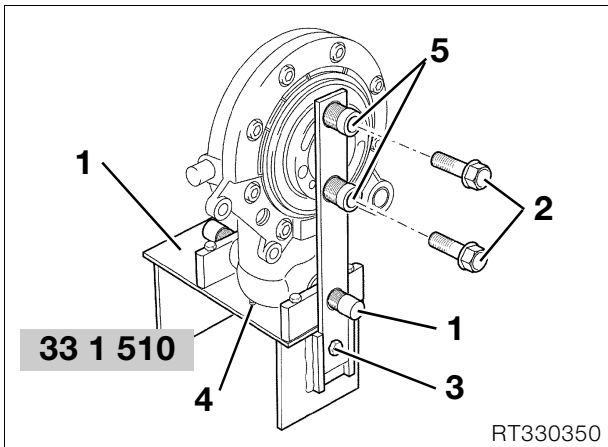

RT330350

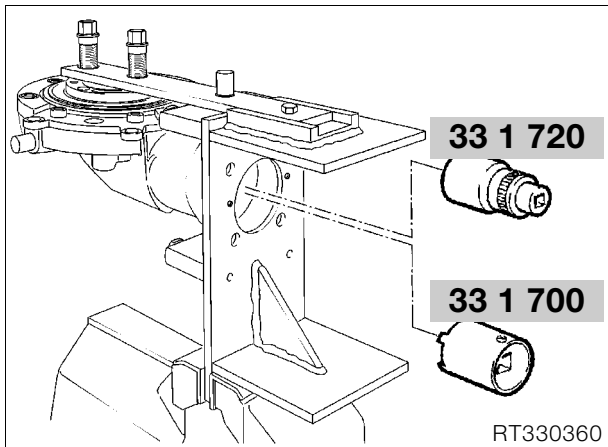

RT330360

- Screw the rear wheel drive centrally with holder, **BMW No. 33 1 510**, and bearing journal (1).
- Screw on locking arm (3).
- Move threaded bushings (5) into contact with the rear wheel drive.
- Secure with wheel bolts (2).
- Screw the grub screws (4) up until they make contact.

- Heat hexagon nut (6) on drive bevel gear to 100 °C and release with 36 mm (1.4173 in) socket wrench insert and reducing adapter, **BMW No. 33 1 720**.

Caution:

Never use a hammer to release the hexagon nut, otherwise the splines can be easily damaged.

- Remove thrust ring (7).
- Heat housing to 120 °C and release threaded ring (8) with pin wrench (2), **BMW No. 33 1 700**.
- Heat bearing seat to 120 °C in order to remove the drive bevel gear (9).

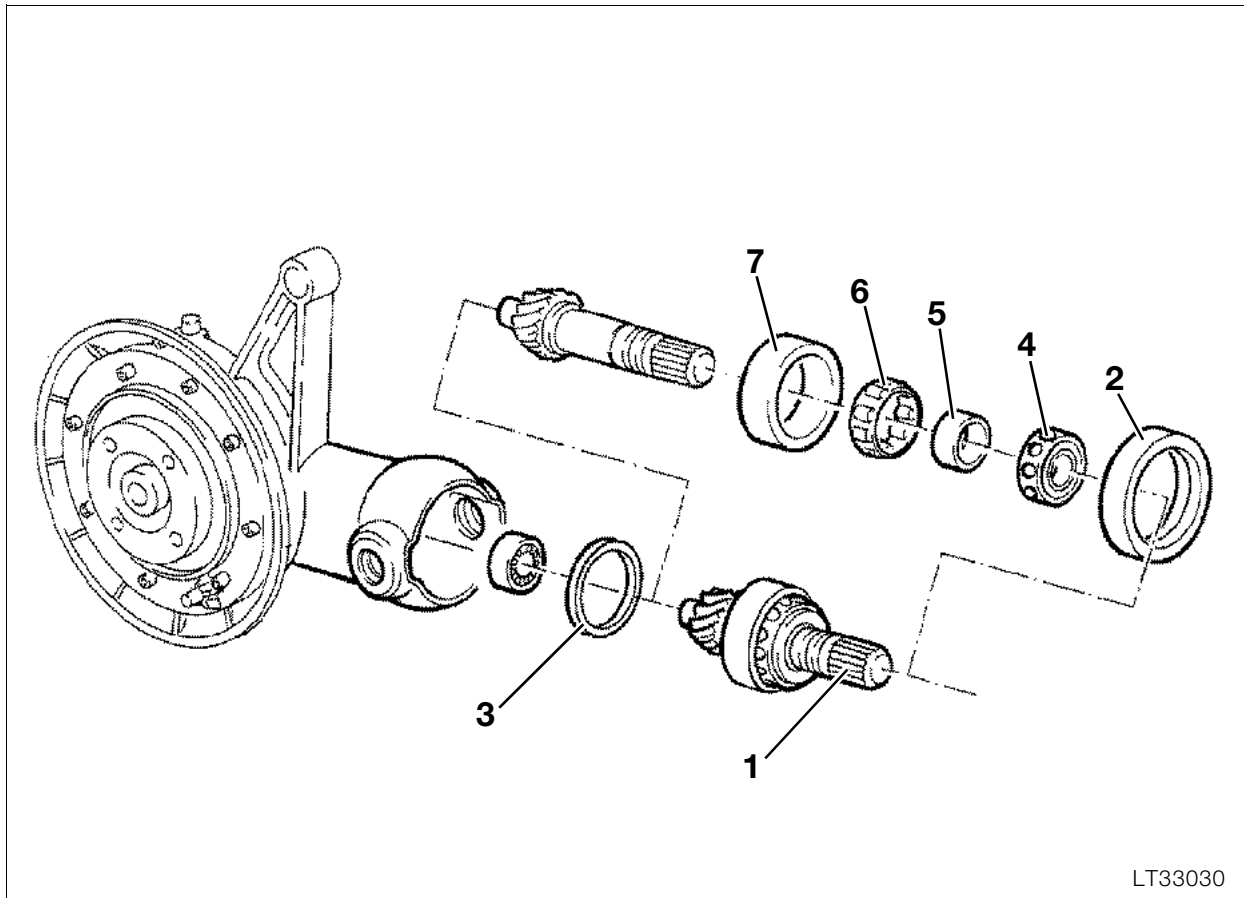

Disassembling drive bevel gear

- Remove outer bearing race (2).
- Remove spacer ring (3) from housing.
- Clamp drive bevel gear (1) in vice with jaw guards (splines facing upward).

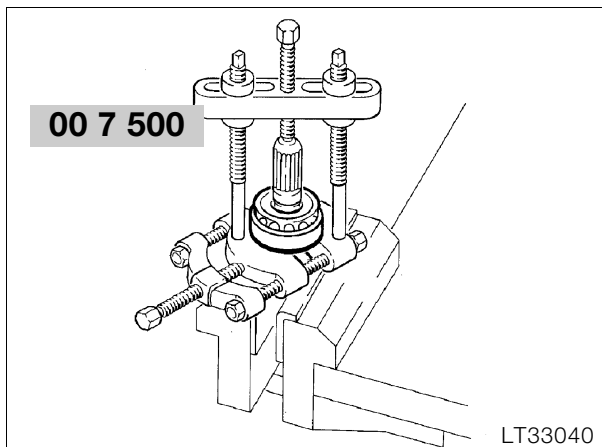

- Using puller, **BMW No. 00 7 500**, remove both bearings at the same time.
- Remove thrust bearing (4), inner race (5), bearing cage (6) and outer race (7).

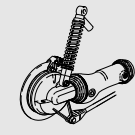

Removing needle bearing for drive bevel gear

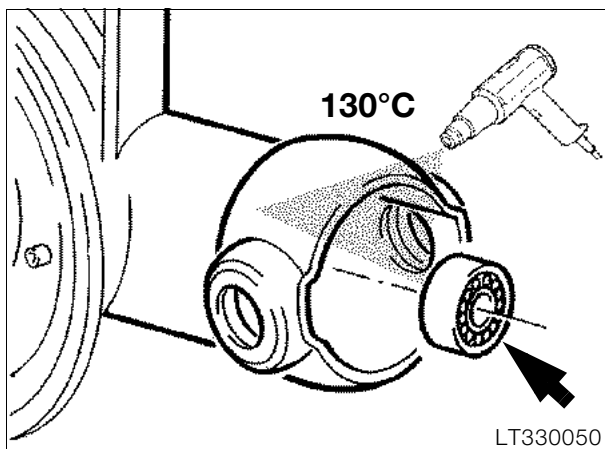

- Destroy needle cage of needle bearing.
- Heat housing to 130 °C.

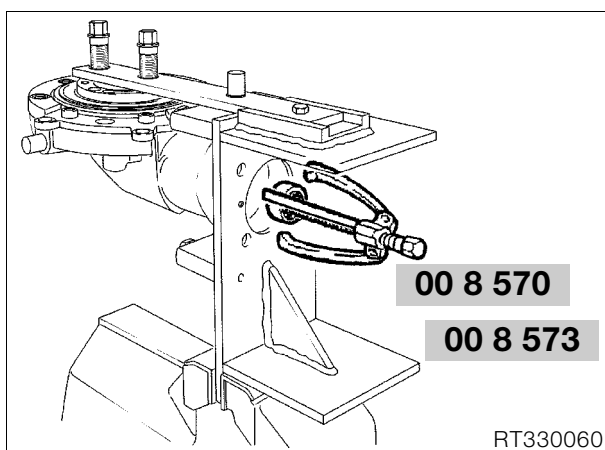

- Remove outer race of needle bearing with the aid of inner extractor, **BMW No. 00 8 573**, and support, **BMW No. 00 8 570**.

Installing needle bearing for drive bevel gear

- Heat bearing seat of needle bearing to 100 °C.
- Press in needle bearing with suitable drift or the drive bevel gear.

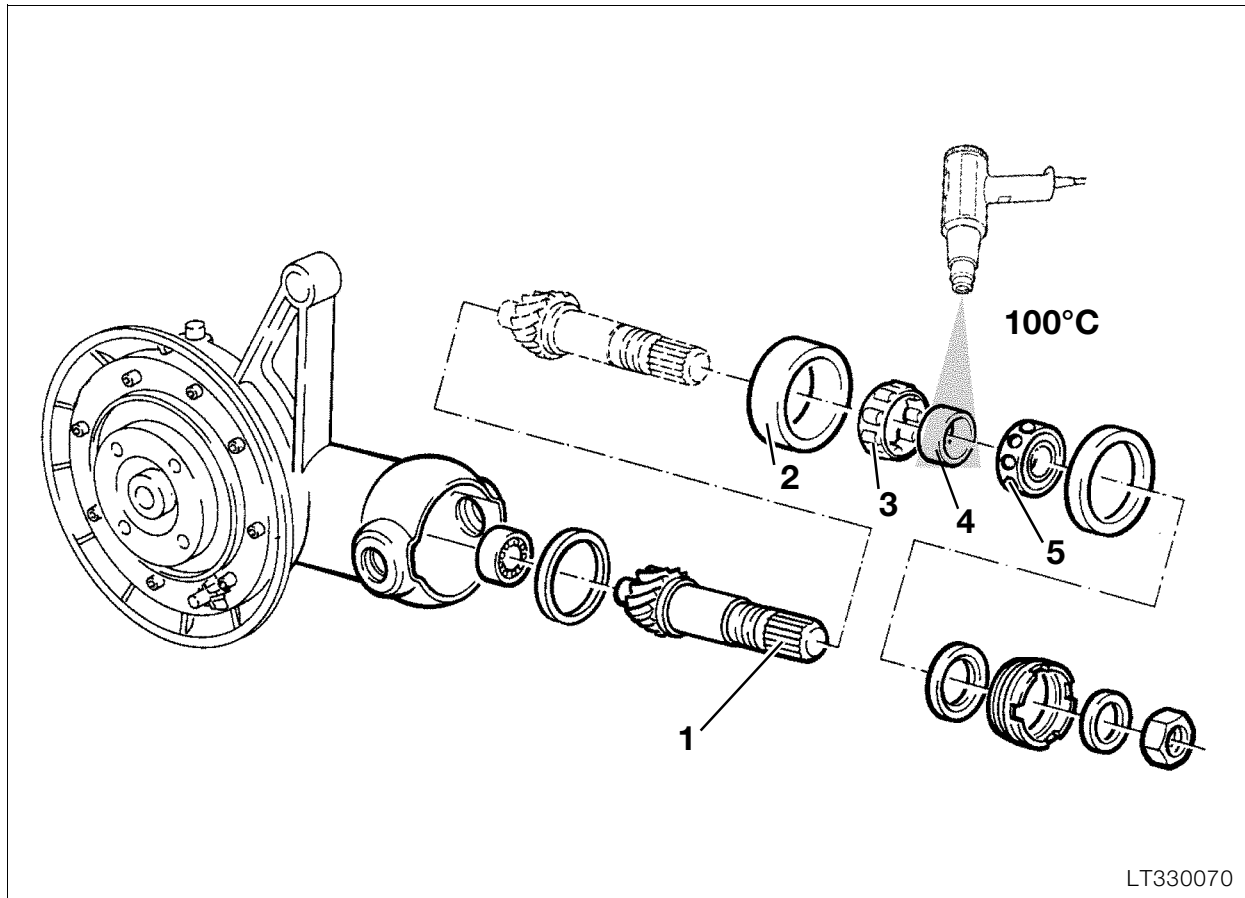

LT330070

Assembling drive bevel gear

- Heat inner race (4) to 100 °C and slide onto drive bevel gear (1) as far as it will go.
- Slide outer bearing race (2) together with cylinder roller cage (3) onto inner race (4).
- Heat ball bearing (5) to 100 °C and fit on drive bevel gear (1) as far as it will go.
- Allow drive bevel gear to cool down.

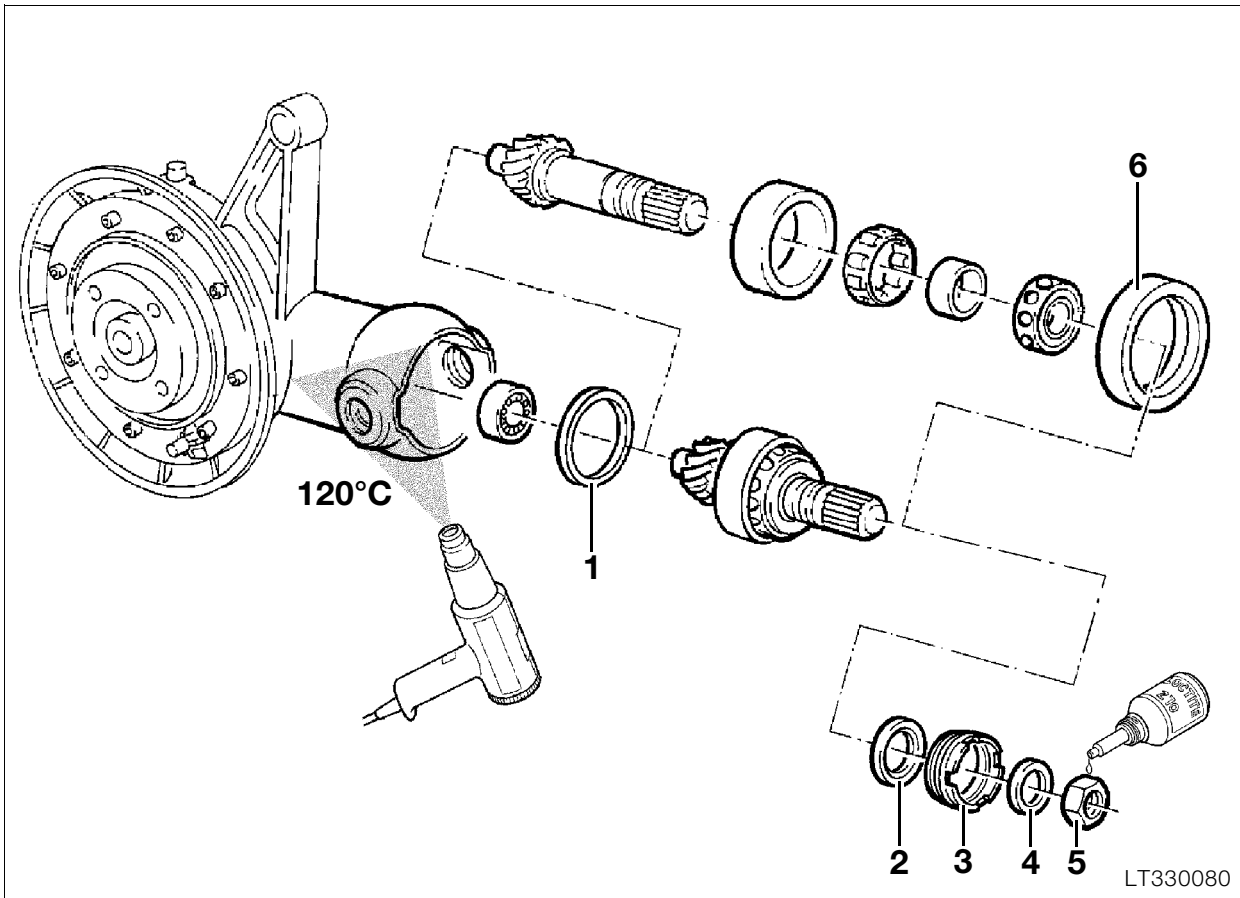
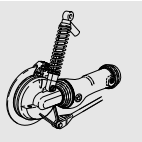

Installing drive bevel gear

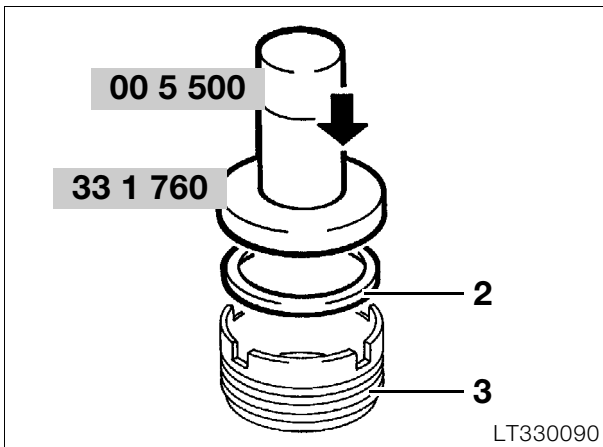

- Drive sealing ring (2) into threaded rim (3) with the aid of drift, **BMW No. 33 1 760**, and retainer, **BMW No. 00 5 550**.
- Heat housing to 120 °C.
- Fit drive bevel gear complete with spacer (1).
- Fit outer race (6).
- Coat threaded ring (3) with **Hylomar SQ 32 M**, thread turns must be free of grease.
- Firmly tighten threaded ring with pin wrench, **BMW No. 33 1 700**.
- Fit thrust ring (4).

Note:

Ensure the sealing lip of the shaft sealing ring is fitted correctly at the thrust ring.

- Coat hexagon nut (5) with **Loctite 270**, thread turns free of grease and firmly tighten using 36 mm (1.4173 in) insert, **BMW No. 33 1 720**.

Caution:

Nut must not damage shaft sealing ring!

Tightening torque:

Threaded ring
(clean thread + Hylomar SQ 32M) 118 Nm
Nut for drive bevel gear
(clean thread + Loctide 273)..... 200 Nm

Removing and installing taper needle bearing in rear wheel drive

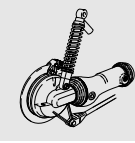
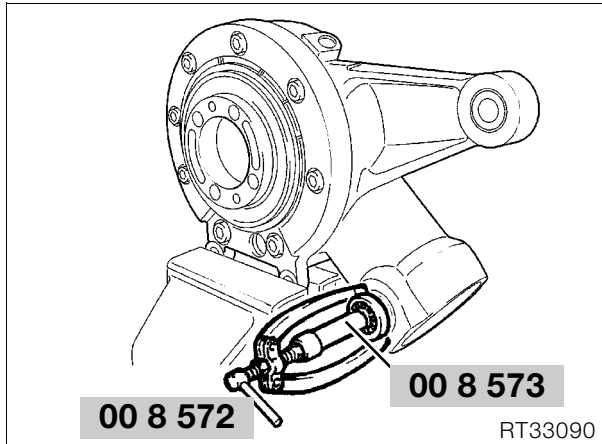

- Remove needle bearing using inner extractor 21/4, **BMW No. 00 8 573**, and support 22/1, **BMW No. 00 8 572**.
- Heat housing neck to 120 °C.
- Press in needle bearing with inner race on drift, **BMW No. 36 3 700**.

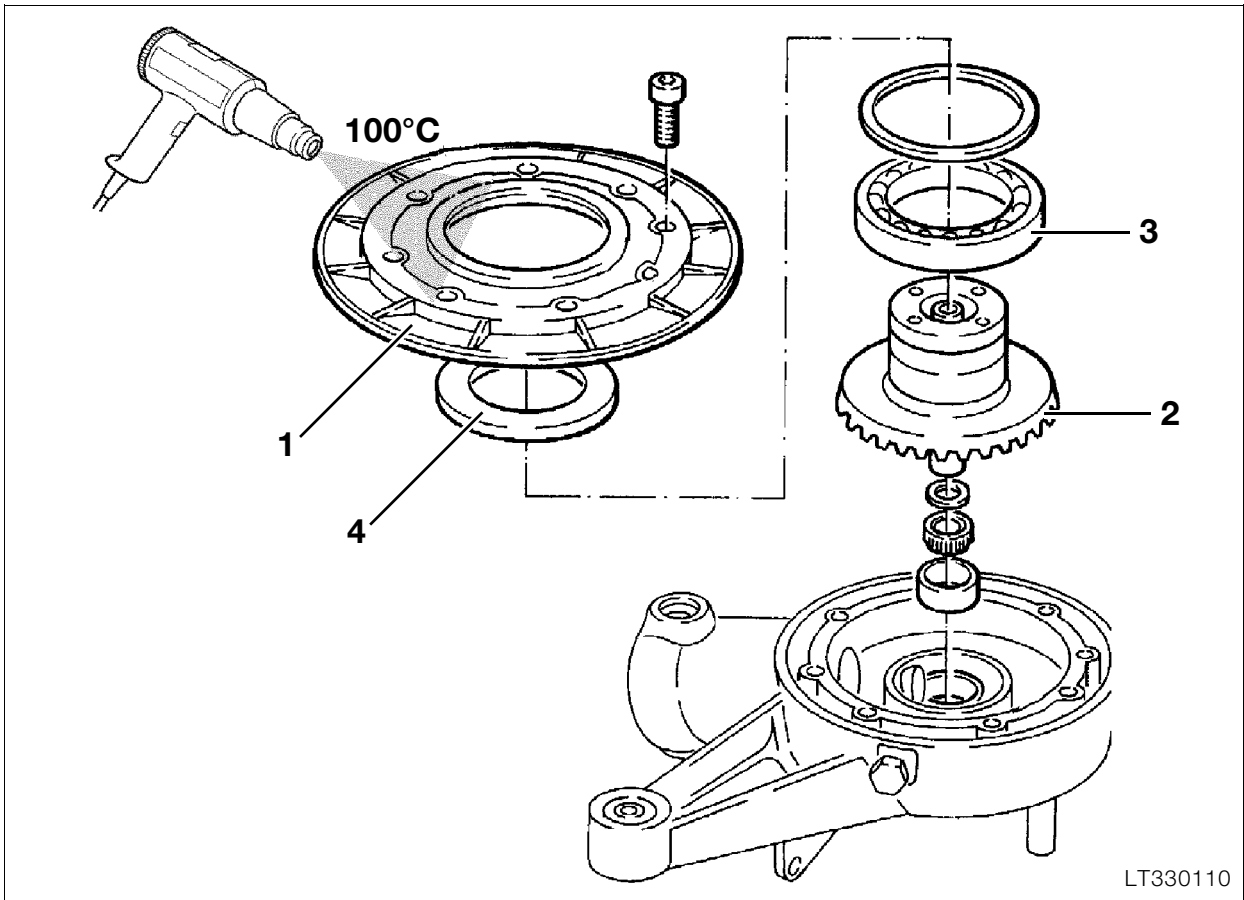

LT330110

Removing crown wheel

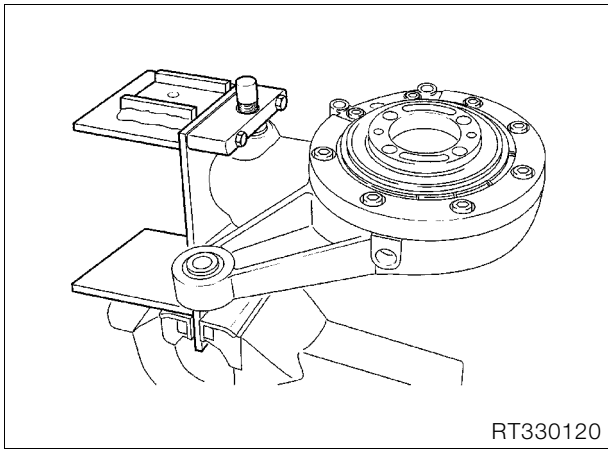

RT330120

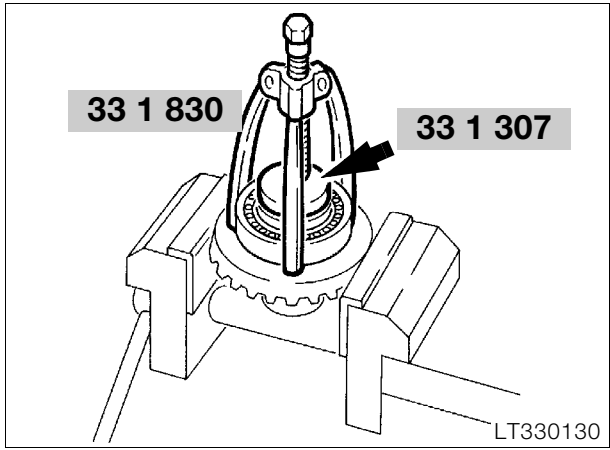

LT330130

- Remove housing cover (1) with crown wheel (2) and bearing (3).
- Heat housing cover (1) to 100 °C and remove.
- Drive shaft sealing ring (4) out of housing cover using drift.

- Clamp ring gear in vice with jaw guards.
- Fit pressure piece (arrow), **BMW No. 33 1 307**.
- Using puller, **BMW No. 33 1 830**, remove deep-groove ball bearing.

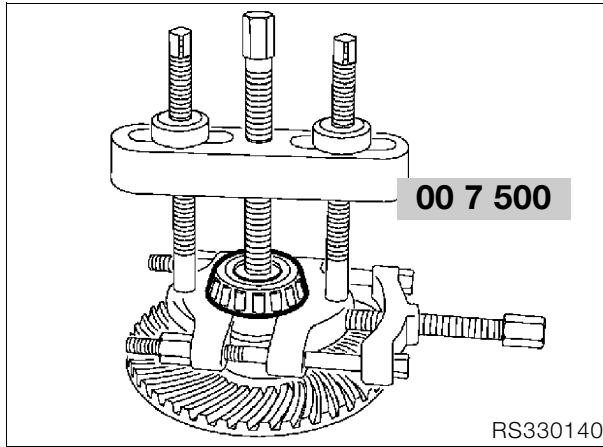

- Remove taper roller bearing from ring gear with puller, **BMW No. 00 7 500**.

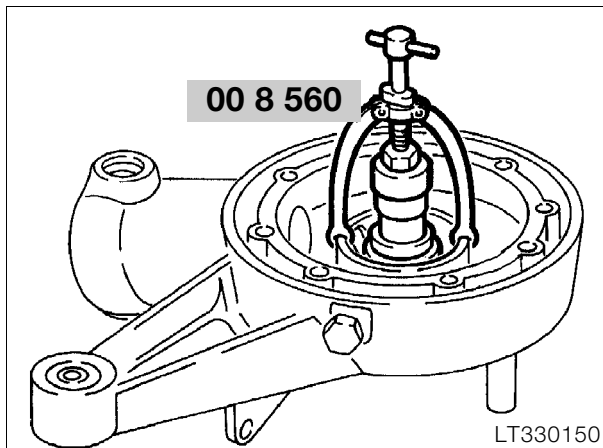

- Remove outer bearing race with internal extractor, **BMW No. 00 8 560**.

Installing crown wheel

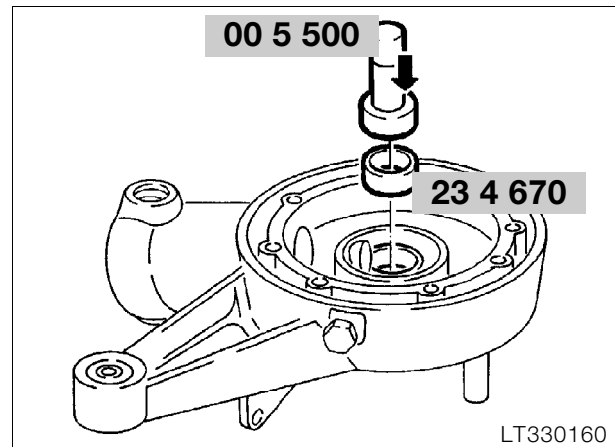

- Heat housing to 80 °C.
- Press outer race into bearing seat with drift, **BMW No. 23 4 670**, and handle, **BMW No. 00 5 500**.



Note:

Check that outer race is correctly seated by light blows.



Note:

The tooth backlash must be checked and adjusted if necessary if new parts have been installed, e.g. the taper roller bearing.

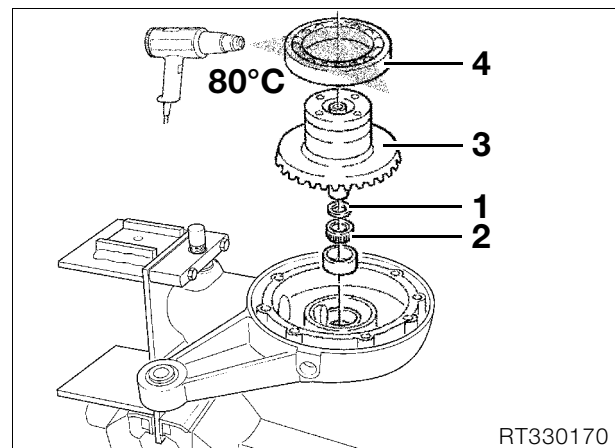

- Fit existing spacer ring (1) on the crown wheel.
- Heat taper roller bearing (2) to 80 °C and fit in position.
- Install (3).
- Heat deep groove ball bearing (4) to 80 °C and fit in position.

Checking/adjusting tooth backlash

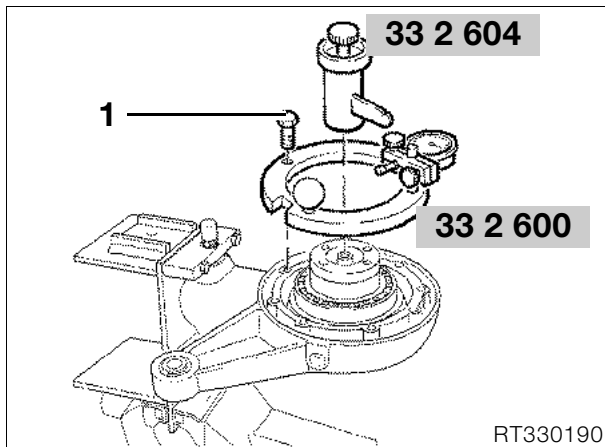
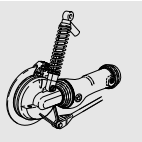

- Lock drive bevel gear in position with 36 mm (1.4173 in) insert, **BMW No. 33 1 720**.
- Fit measuring ring, **BMW No. 33 2 600**, with dial gauge on crown wheel and secure to housing with knurled screw (1).
- Secure measuring arm, **BMW No. 33 2 604**, centrally on crown wheel.

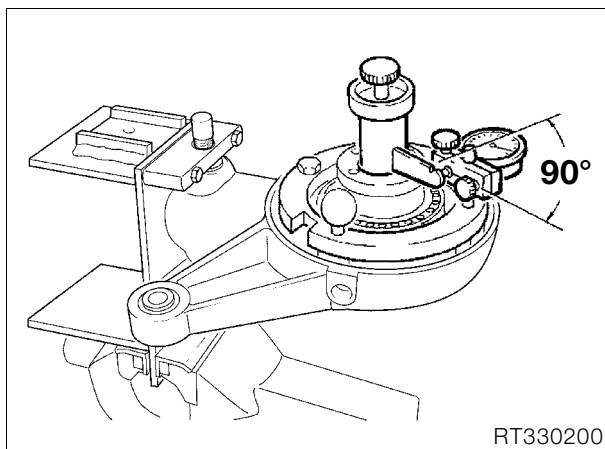

- With the palm of the hand, press crown wheel into housing and check gear backlash by turning backward and forward.



Note:

Check the backlash at three points offset by 120°, turn bevel gear with crown wheel.

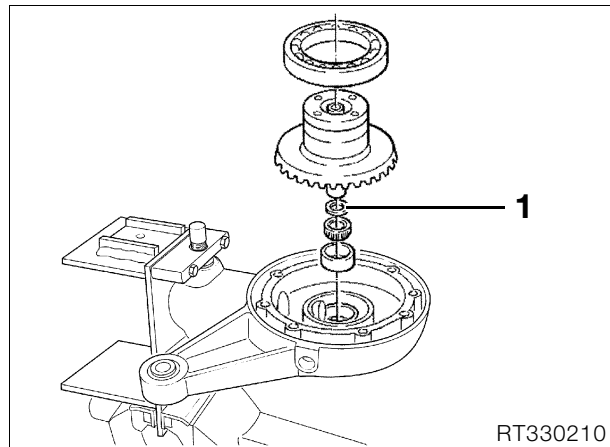

- Take up excessively large gear backlash by fitting a thin spacer and too little gear backlash by fitting a thick spacer (1).

Gear backlash:

(adjust without oil) 0.07...0.16 mm
 (0.002756...0.006299 in)

Checking contact pattern

- The contact pattern must be checked when the set of gears, the housing or the bearing of the drive bevel gear has been replaced.

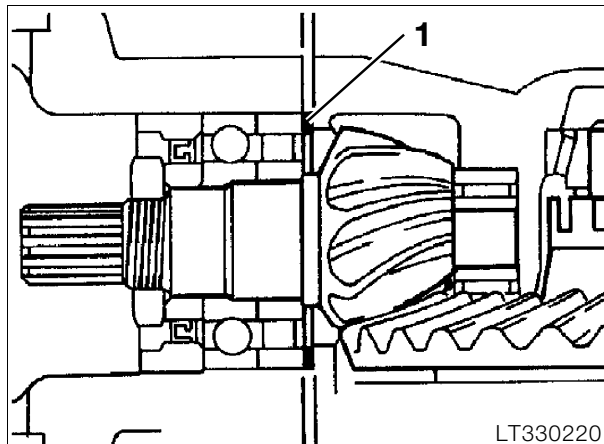

Note:

The contact pattern is set with the spacer ring?(1) on the drive bevel gear.

- Remove grease from the tooth profiles of the crown wheel and bevel gear and coat with engineer's blue or white oil paint.
- Fit crown wheel, press into housing with palm of hand and turn forward and backward several times.

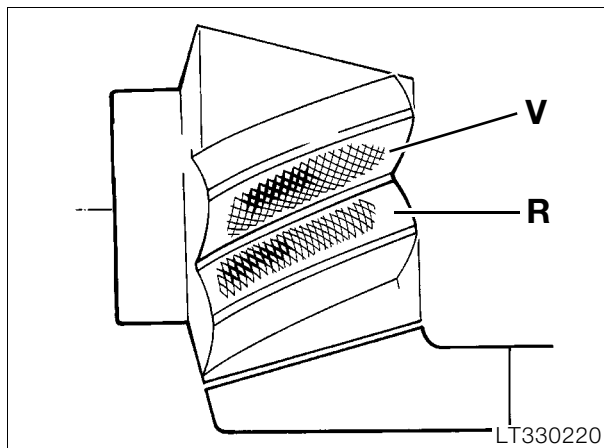

- If the correct spacer ring is installed, the no-load contact pattern as shown above should be obtained.



Note:

The contact pattern is in the centre of the forward profile "V".

The contact pattern is nearer the large diameter on the reverse profile "R".



Caution:

The teeth should never touch at the small diameter!

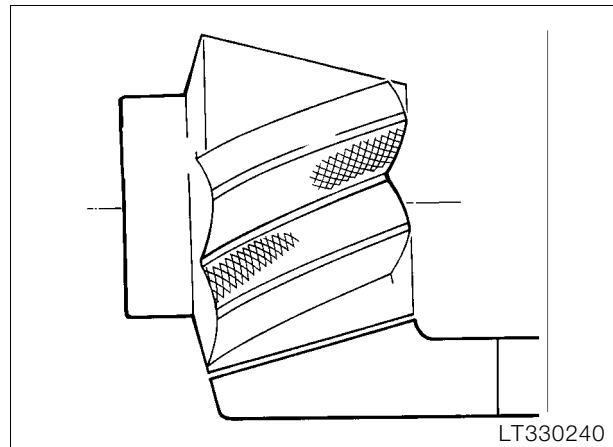

- If this contact pattern is obtained, a thinner spacer ring must be installed.

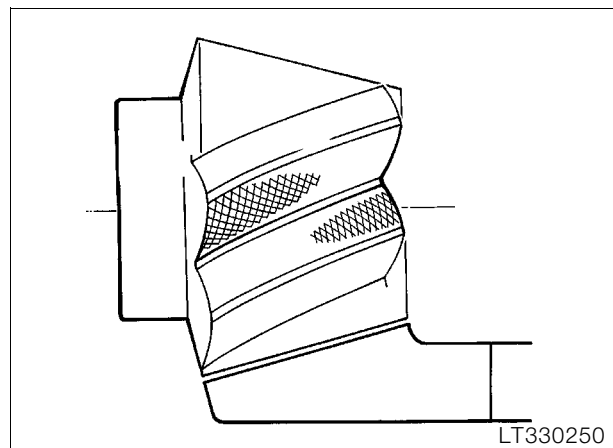

- If this contact pattern is obtained, a thicker spacer ring must be installed.

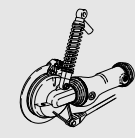

Shimming housing cover

- The housing cover must be shimmed in order to achieve the corresponding preload of the taper roller bearing.

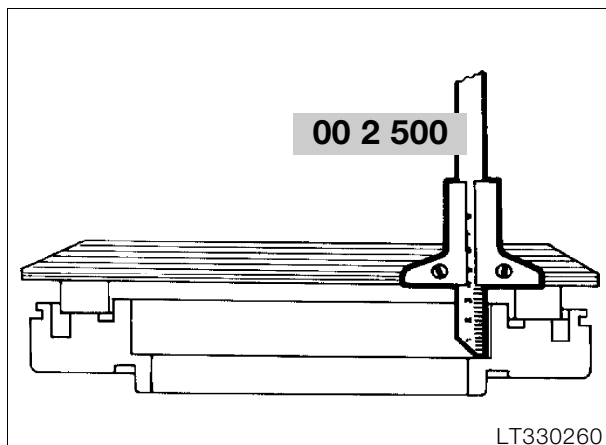

- Measure distance "a" with depth gauge, **BMW No. 00 2 500**.

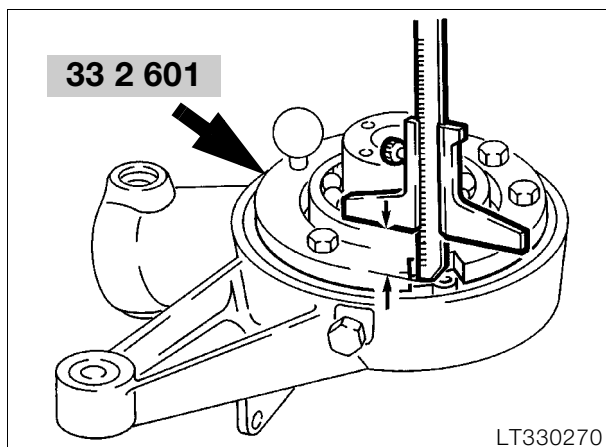

- Fit measuring ring (arrow), **BMW No. 33 2 601**
- Measure from the outer race of the ball bearing to the parting surface of the housing through the cutout in the measuring ring.
- Dimension "a" – dimension "b" = thickness of shim without preload.
- Lightly grease determined spacer ring and fit in position.

Preload..... 0.05...0.1 mm (0.00197...0.003937 in)

Installing housing cover

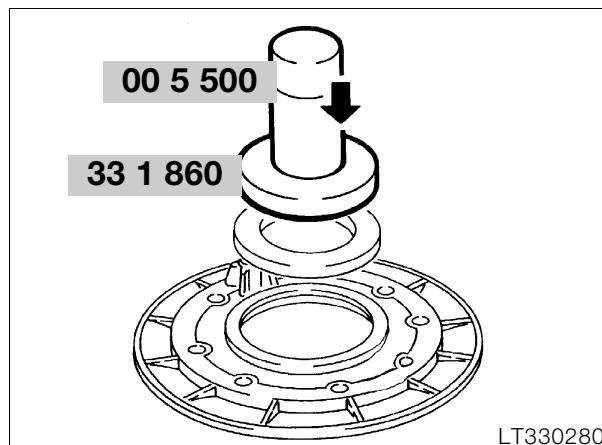

- Drive in sealing ring using drift, **BMW No. 33 1 860**, and handle **BMW No. 00 5 500**.
- Install O-ring lightly oiled/greased.
- Fit housing cover in position and heat to 80 °C.
- Tighten retaining bolts crosswise.

 **Tightening torque:**
Housing cover, M 10 x 30 (with Paralever) ...35 Nm

Installing slider

- Coat spline on drive pinion with "**Optimoly MP3**".
- Fit slider piece on drive pinion.
- Engage the retaining ring with light hammer blows (plastic-headed hammer).

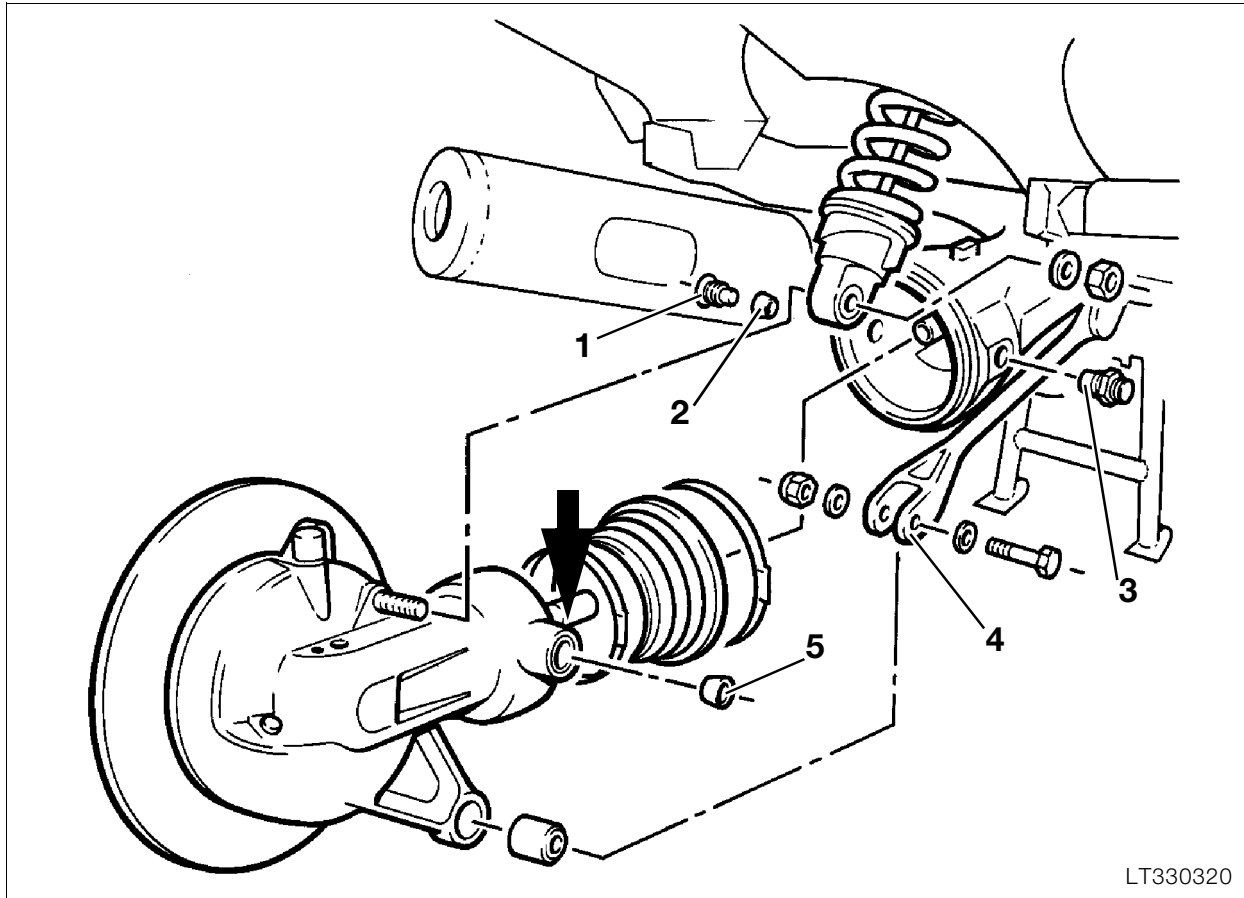

LT330320

Installing rear wheel drive

- Coat spline on sliding piece (arrow), for example with **Optimoly MP3**.
- Fit inner race (5) of right-hand needle bearing with a little grease, e.g. **Optimoly TA**.
- Fit rear wheel drive with gaiter in position, insert sliding piece in drive shaft.
- Loosely secure spring strut to rear wheel drive.

Caution:

The bearing pin of the fixed bearing (1) is micro-encapsulated, clean thread!

- Screw in bearing pin (1) with **Loctite 2701**.

Caution:

The inner bearing race must never press against the end faces of the needles!

Tightening torque:

Bearing pin of fixed bearing 150 Nm
(clean thread + Loctite 2701)

- Screw in the bearing pin of the loose bearing (3) with **Loctite 2701**.

Tightening torques:

Bearing pin of loose bearing 7 Nm
(clean thread + Loctite 2701 applied to entire length of thread on loose bearing pin)
Locknut 105 Nm

Caution:

The final tightening torque must be applied without delay to threaded connections secured with **Loctite 2701**. The Loctite requires at least 3 hours to harden.

Note:

To clean use an acetone-based cleaning product, e.g.
Loctite 706 rapid cleaner
(Loctite order No. 70636-AC).

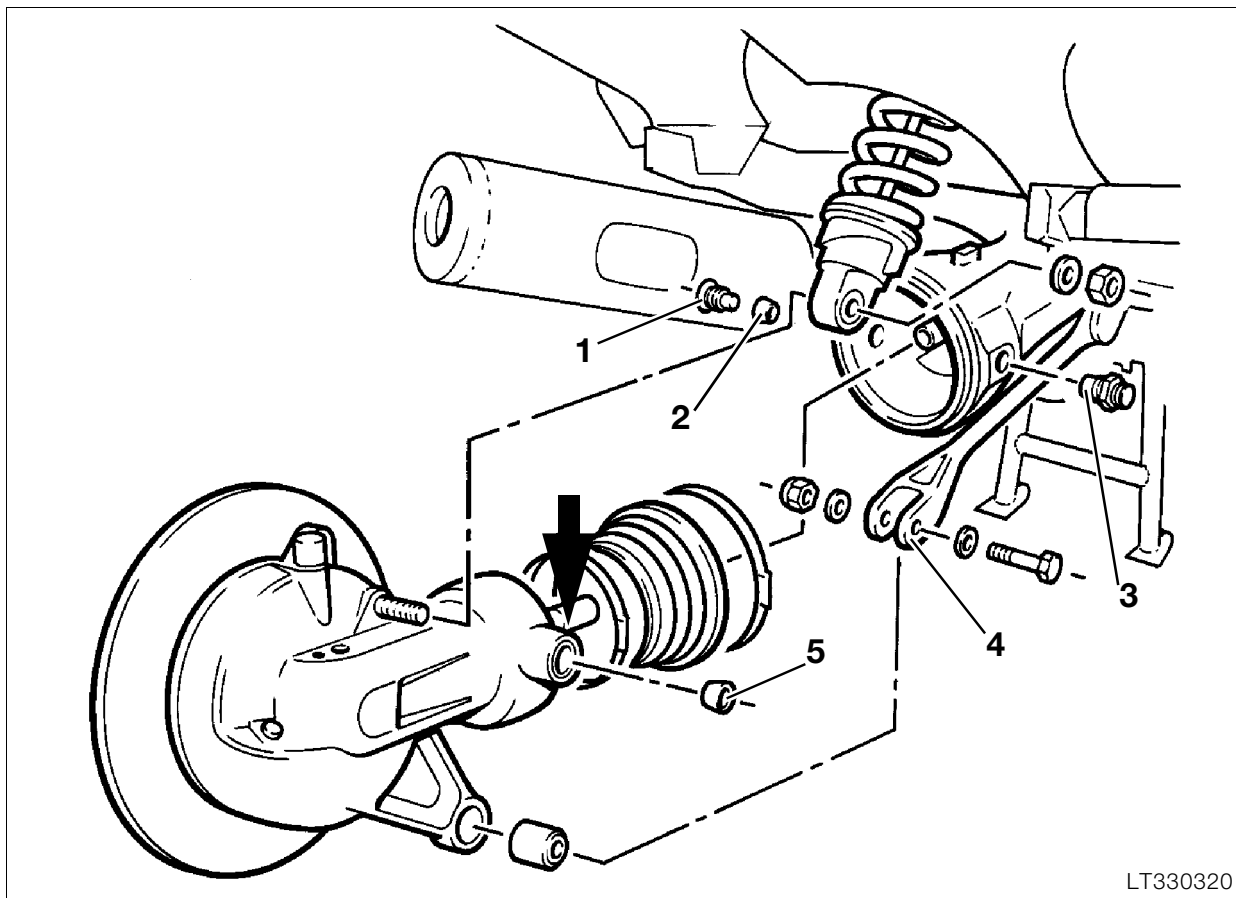
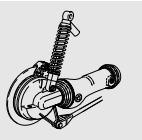

- Apply a load of approx. 85 Kg (1887.43 lb) to the motorcycle and tighten loose strut (4) with the nut on the wheel side.

- Install the rear wheel, insert the wheel studs and tighten them in the specified order.

Tightening torques:

Strut to rear wheel drive	43 Nm
Suspension strut to rear wheel drive	51 Nm

- Tighten the strap holding the flexible gaiter.
- Add oil.

Oil content:

Initial filling.....	0.25 l (0.44 Imp.pt)
First oil change.....	0.23 l (0.41 Imp.pt)

Gear oil grade:

Use brand-name hypoid gear oil, SAE 90, API Class GL 5.



Note:

Add oil only up to the lower edge of the thread in the filler aperture.

- Install the brake disc in the previously marked position

Tightening torque:

Brake disc to rear wheel drive	21 Nm
--------------------------------------	-------

Tightening torques:

wheel studs:	
Stage 1	50 Nm
Stage 2	105 Nm

- Install the brake caliper

Caution:

Do not damage or tilt the brake pads.

- **[ABS]** Check sensor gap.

[ABS] Rear sensor gap	0.60 . . . 0.65 mm
.....	(0.0236...0.0256)

Anziehdrehmoment:

Brake caliper to rear wheel drive	32 Nm
---	-------

- Install number plate holder.

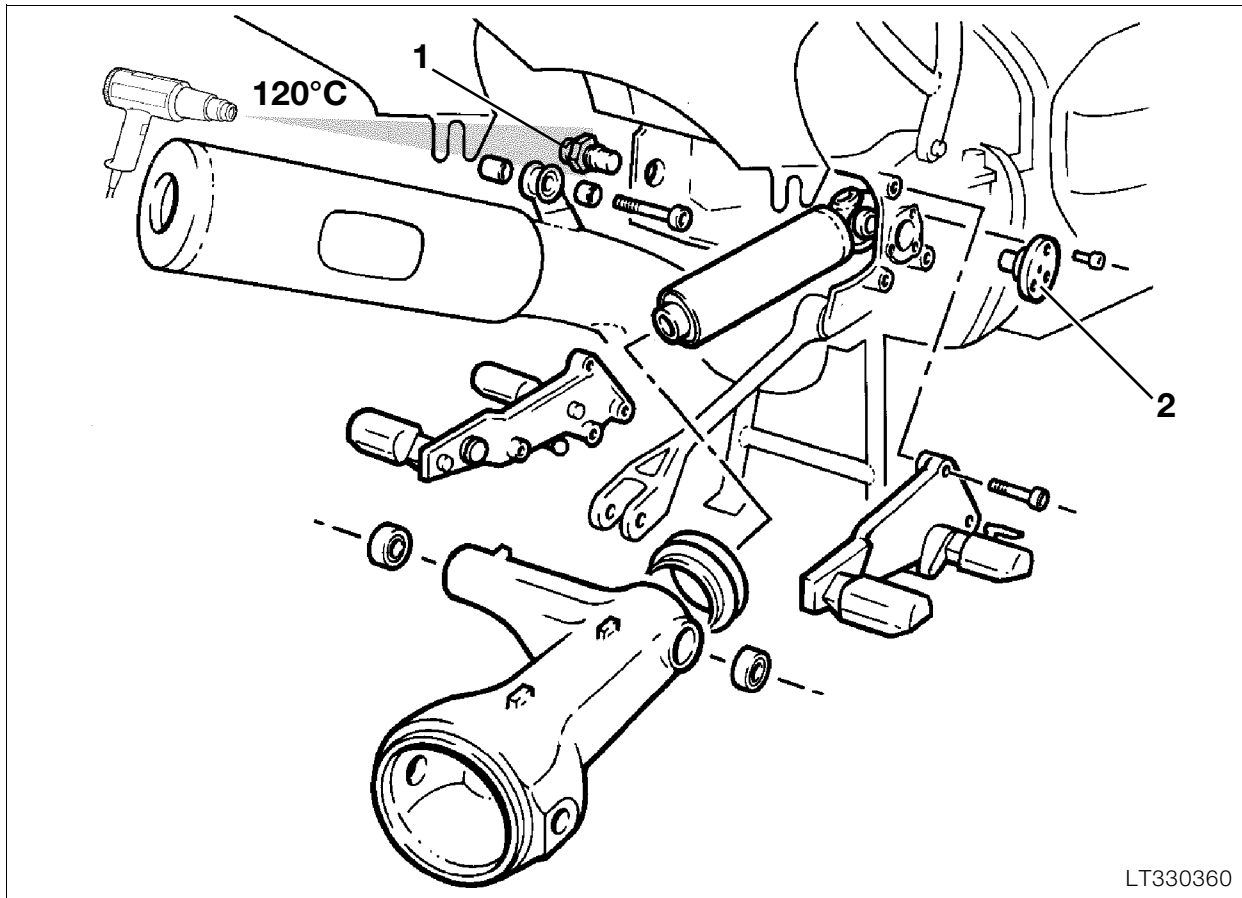

LT330360

Removing, disassembling and assembling rear swinging arm

- Remove left and right footrest plate.
- Heat to max. 120 °C at loose bearing of swinging arm (1), loosen locknut and remove bearing pin.
- Release the centre and two other bolts on the fixed bearing (2).

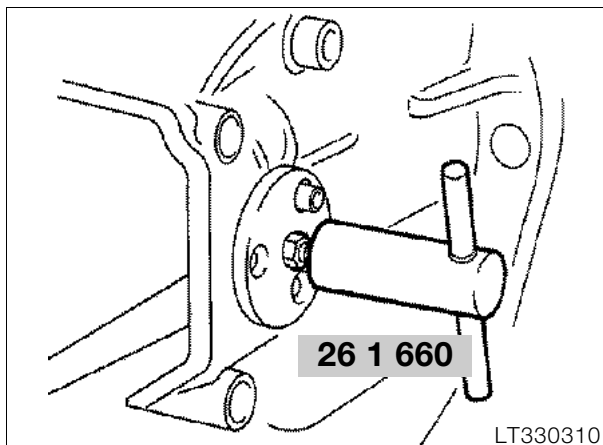

LT330310

- Screw in and lock special tool, **BMW No. 26 1 660**,
- Release fourth retaining bolt and remove swinging arm bearing while turning backward and forward.

Removing and installing taper roller bearing

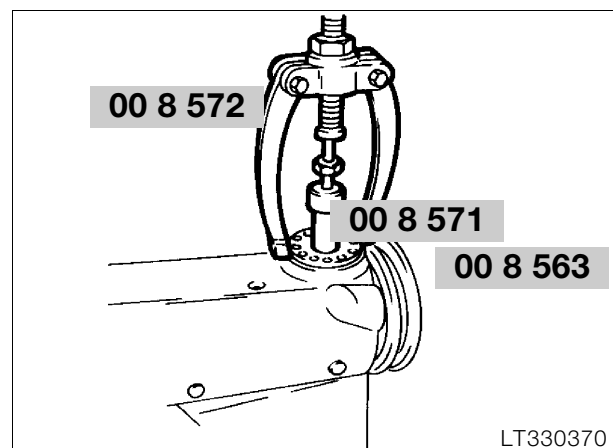

LT330370

- Remove taper roller bearing with support, **BMW No. 00 8 572**, and internal extractor 21/2, **BMW No. 00 8 571**.
- Remove outer bearing race with support, **BMW No. 00 8 572** and inner extractor 21/5, **BMW No. 00 8 563**.
- When installing, heat swinging arm bearing to a temperature of 80 °C.

Removing and installing gaiter

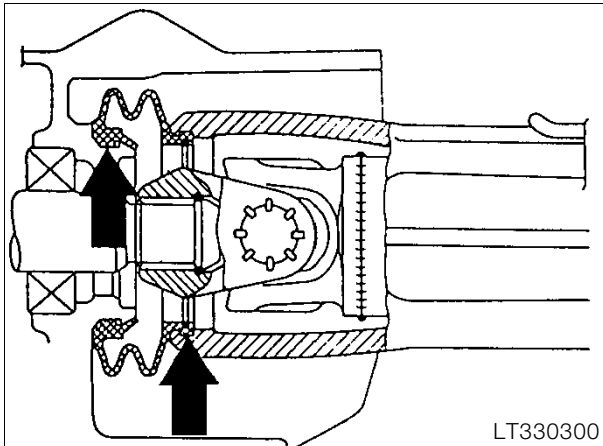

- Remove inner retaining ring, pull gaiter out of swinging arm.
- Install in the reverse order of removal.
- Coat inside and outside (arrows) of sealing lip with, for example, **Optimoly MP3**.

Removing drive shaft

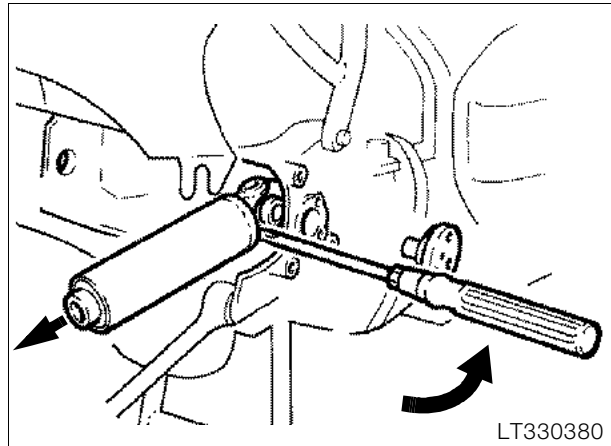

- Press off drive shaft with screwdriver.



Caution:

Avoid scratching painted parts; use a rubber underlay if necessary.

Checking universal joint for wear

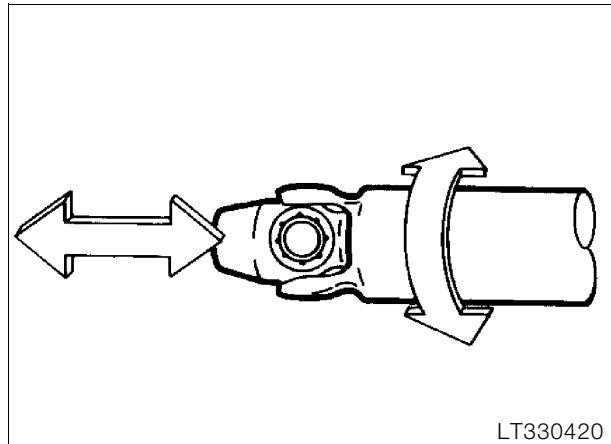

- Determine axial and radial play by shifting axially and turning radially.

Removing retaining ring

- Lever out retaining ring in universal joint using a small screwdriver.
- Install in the reverse order of removal.

Installing drive shaft

- Coat spline of drive shaft with, for example, **Optimoly MP3**.
- Fit drive shaft on output shaft.
- Engage snap ring in position with light blows (plastic-headed hammer).

Installing swinging arm

- Slide swinging arm over drive shaft.
- Lift drive shaft over the support surface in the swinging fork and press forward swinging arm as far as possible until gaiter snaps in position at the gearbox neck.

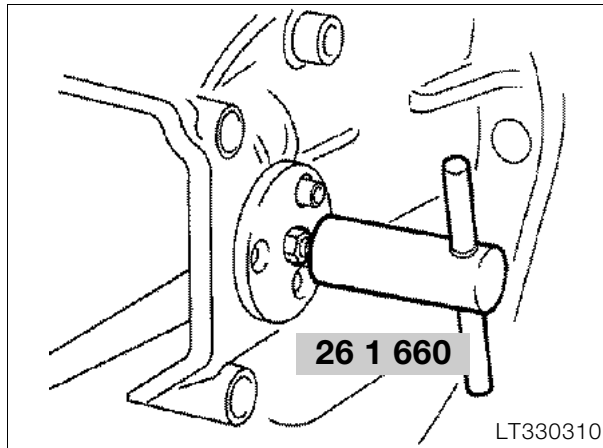

- Coat bearing pin of fixed bearing with **Optimoly TA** and install and firmly tighten with special tool **BMW No. 26 1 660**.

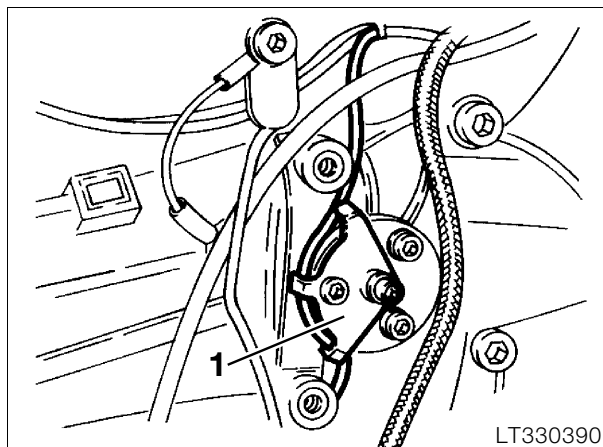

- Install bracket (1) for line of electric side stand switch.

Tightening torque:
Swinging arm fixed bearing 9 Nm

- Coat bearing pin of loose bearing with Optimoly TA, install, firmly tighten and secure locknut.

Tightening torques:
Bearing pin of loose bearing
(clean thread + Loctite 270) 7 Nm
Locknut 41 Nm

Installing footrest plates

- Install left footrest plate.
- **[ABS]** Note earth (ground) cable.
- Mount silencer.

Tightening torques:
Footrest plate to gearbox 15 Nm
Silencer to footrest plate 9 Nm

- Install right footrest plate.
- Carefully arrange all leads and hoses; ensure they are not pinched.
- **[ABS]** Note earth (ground) cable.

Tightening torques:
Footrest plate to gearbox 15 Nm
[ABS I] Support bracket,
pressure modulator 17 Nm

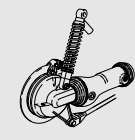

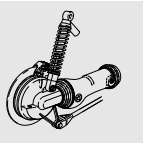

34 Brakes

Contents

Page



Technical Data	3
Removing and installing front brake caliper	5
Dismantling and assembling front brake caliper	6
Dismantling front brake caliper	6
Assembling front brake caliper	7
Removing and installing brake pads	8
Removing and installing front brake disc	9
Removing and installing ABS pulse wheel	9
Removing and installing front ABS sensor	10
Adjusting front ABS sensor gap	11
Removing and installing front brake line	12
Removing upper brake line	12
Removing lower brake line	12
Removing and installing ABS brake line from front pressure modulator ...	13
Removing and installing handbrake cylinder	14
Bleeding brake	15
Bleeding front brake	15
Bleeding brake caliper	15
[ABS II] Bleeding pressure modulator	16
Bleeding the handlebar fitting	16
Bleeding rear brake	16
Bleeding brake caliper	16
[ABS II] Bleeding pressure modulator	16
Removing and installing pressure modulator	17
[ABS I] Removing and installing front or rear pressure modulator	17
[ABS II] Removing ABS unit	18

[ABS II] Installing ABS unit	19
[ABS II] Removing and installing relay and relay base	20
[ABS II] Removing relay	20
[ABS II] Installing relay	20
[ABS II] Removing relay base	21
[ABS II] Installing relay base	21
Removing and installing rear brake caliper	22
Removing and installing rear brake pads	22
Dismantling and assembling rear brake caliper	23
Dismantling rear brake caliper	23
Assembling rear brake caliper	23
Removing and installing rear brake disc	24
Removing and installing rear ABS sensor	25
Measuring vertical runout at rear pulse wheel	26
Removing and installing rear master brake cylinder	27
Disassembling rear master brake cylinder	28
Removing and installing brake pedal	29
Adjusting foot brake pedal	30
Troubleshooting: Front wheel/rear wheel brake	31

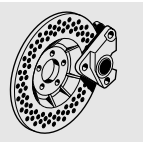

Technical Data		K 1100 LT	K 1100 RS
Brake fluid		DOT 4	
Minimum brake pad thickness	mm (in)	1.5 (0.059)	
Front wheel			
Brake disc Ø	mm (in)	305 (12.01)	
Brake disc thickness	mm (in)	5 ^{± 0.1} (0.197 ± 0.0039)	
Minimum thickness	mm (in)	4.5 (0.177)	
Brake pad surface	cm ² (in ²)	100 (15.5)	
Piston Ø of brake caliper	mm (in)	32/34 (1.26/1.34)	
Piston Ø handbrake cylinder	mm (in)	20 (0.79)	
ABS front sensor gap (measured at max. distance point)	mm (in)	0.50...0.55 (0.0197...0.0216) Up to 1996 MY 0.45...0.55 (0.0177...0.0216) From 1997 MY	
Rear wheel			
Brake disc Ø	mm (in)	285 (11.22)	
Brake disc thickness	mm (in)	5 ^{± 0.2} (0.197 ± 0.00787)	
Minimum thickness	mm (in)	4.6 (0.181)	
Permissible lateral runout	mm (in)	0.2 (0.0078)	
Brake pad surface	cm ² (in ²)	41.5 (6.43)	
Piston Ø brake caliper	mm (in)	38 (1.496)	
Piston Ø foot brake cylinder	mm (in)	12 (0.472)	
ABS rear sensor gap (measured at max. distance point)	mm (in)	0.60...0.65 (0.0236...0.0256) Up to 1996 MY 0.45...0.55 (0.0177...0.0216) From 1997 MY	

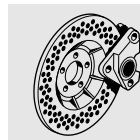

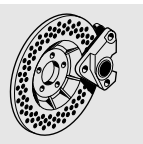

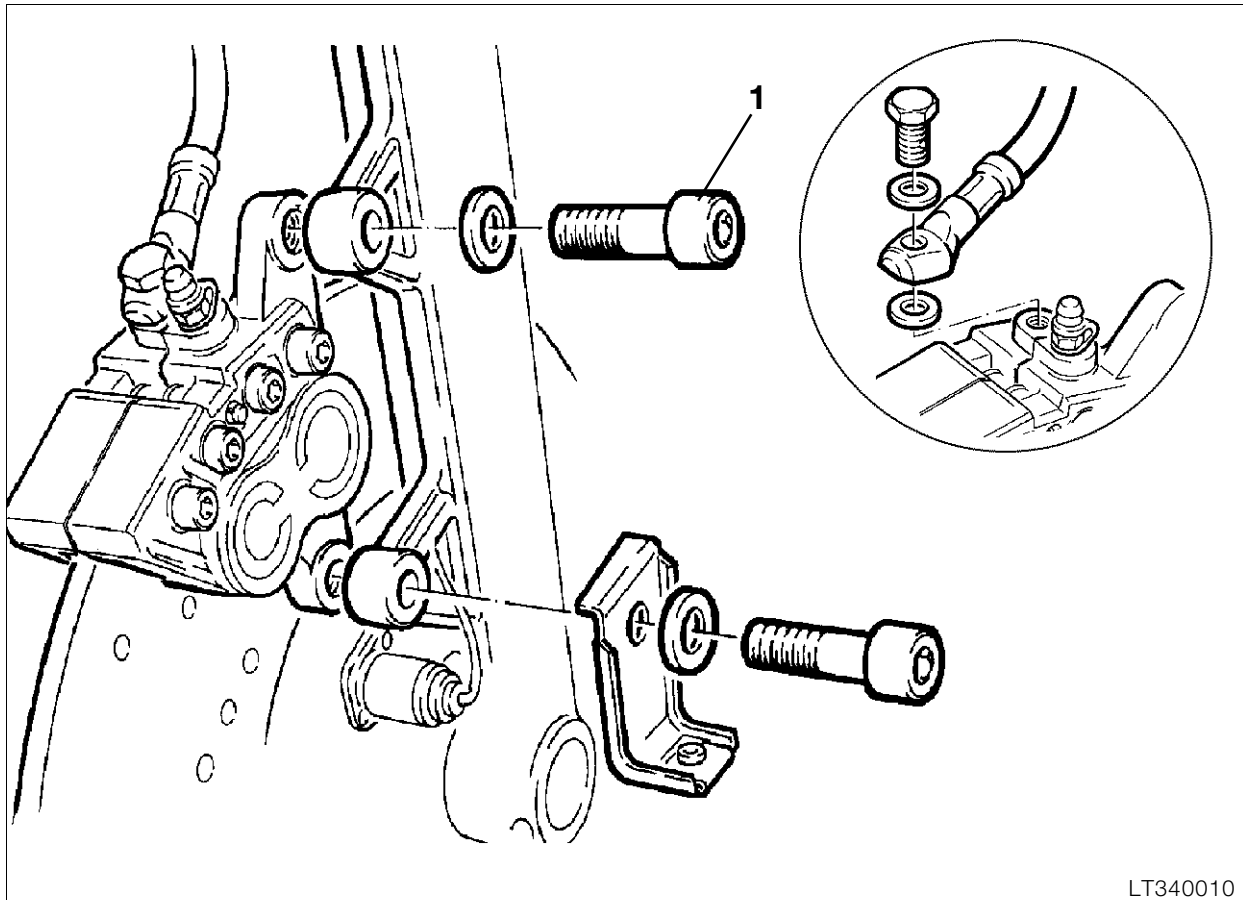

LT340010

Removing and installing front brake caliper

- Mask off brake caliper at top of wheel side with tape (rim guard).

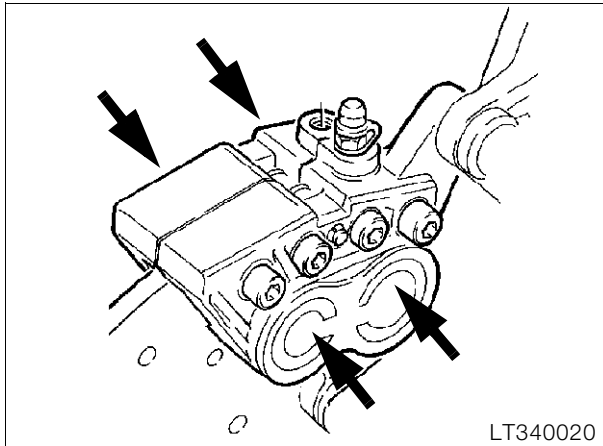

LT340020

- Release brake caliper mounting (1) and alternately press brake caliper against the brake disc and pull back (arrow) in order to press back the pistons.
- Carefully remove brake caliper from brake disc.

Caution:

Brake pads must not be damaged.

- Release brake line at brake caliper and close off.

Caution:

Ensure brake fluid does not come in contact with painted vehicle parts; brake fluid destroys the paint work.

- Install in the reverse order of removal.

Note:

Renew sealing rings.

Tightening torques:

Brake caliper to slider tube	40 Nm
Brake line to brake caliper.....	18 Nm
Bleed screw	14 Nm

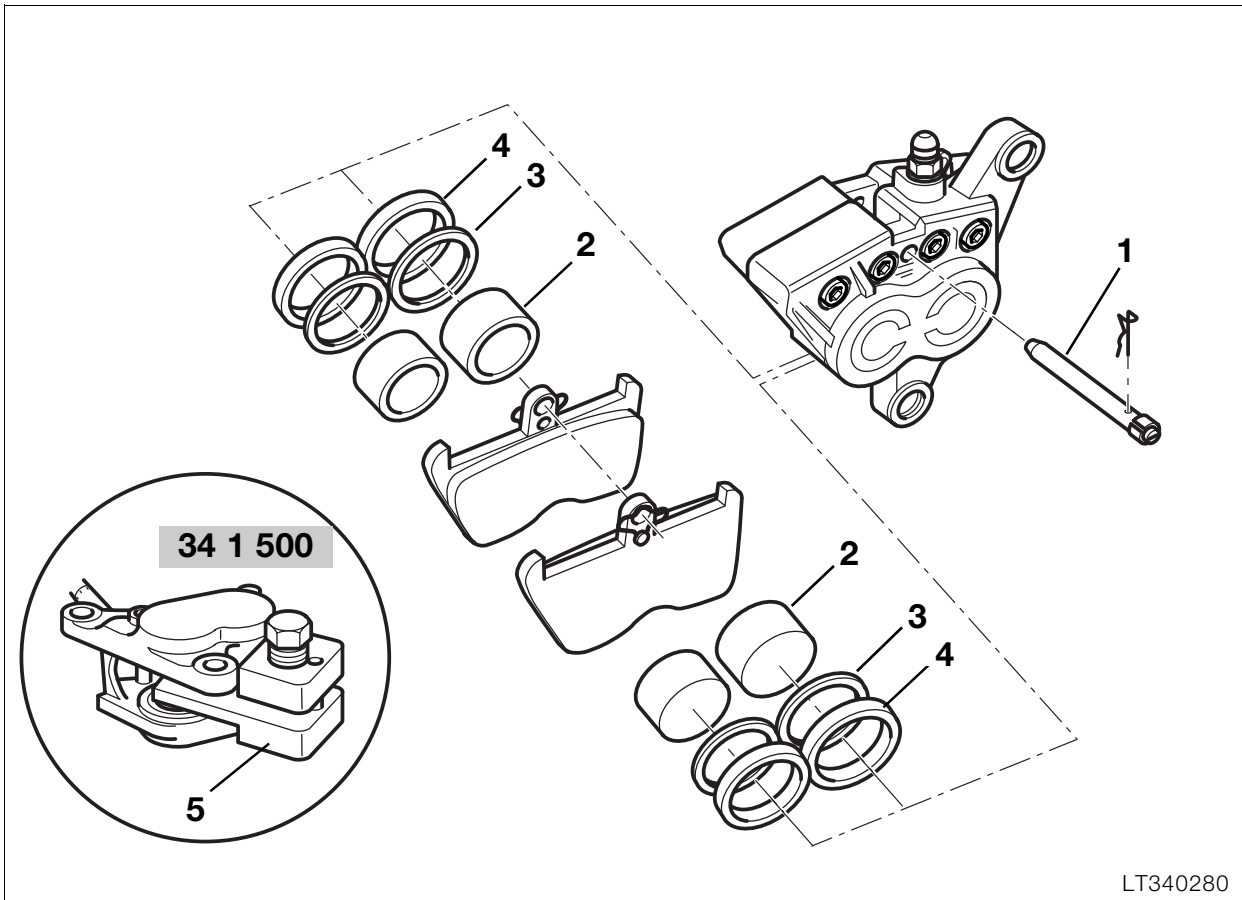
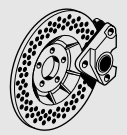

Dismantling and assembling front brake caliper



Caution:

The brake caliper halves must **not be unscrewed!**

- Hold a cloth over the brake caliper.
- **Carefully** press out brake pistons (2), using a compressed air gun at the brake line connection.

Dismantling front brake caliper

- Remove the brake caliper.
- Remove keeper from retaining pin (1).
- Drive out the retaining pin (1) from the wheel side.
- Pull the brake pads out downwards.
- Seal the bleed screw.



Caution:

Do not allow your fingers to become trapped between the pistons; risk of injury.

- Remove the two sealing rings (3,4) from the left/right brake cylinder bores.
- Examine the brake caliper pistons for damage.



Tightening torque:

Bleed screw at brake caliper front 14 Nm

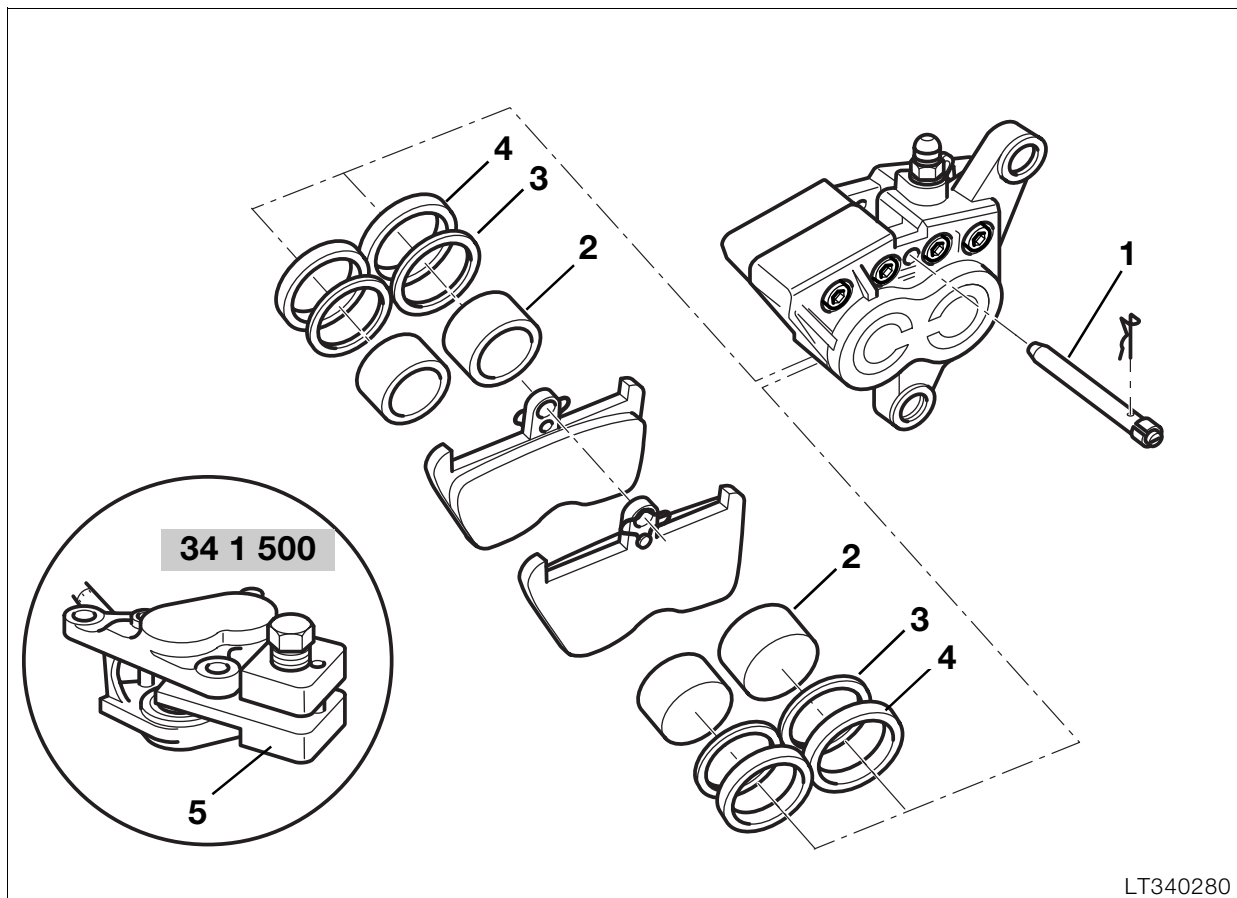

LT340280

Assembling front brake caliper

- Coat new sealing rings (3,4) with brake fluid and install.
- Coat brake caliper pistons (2) with brake fluid and insert.



Caution:

Do not tilt the brake pistons when installing.

- Using piston resetting tool (5), **BMW No. 34 1 500**, press the pistons fully back.
- Insert brake pads and secure with retainers.

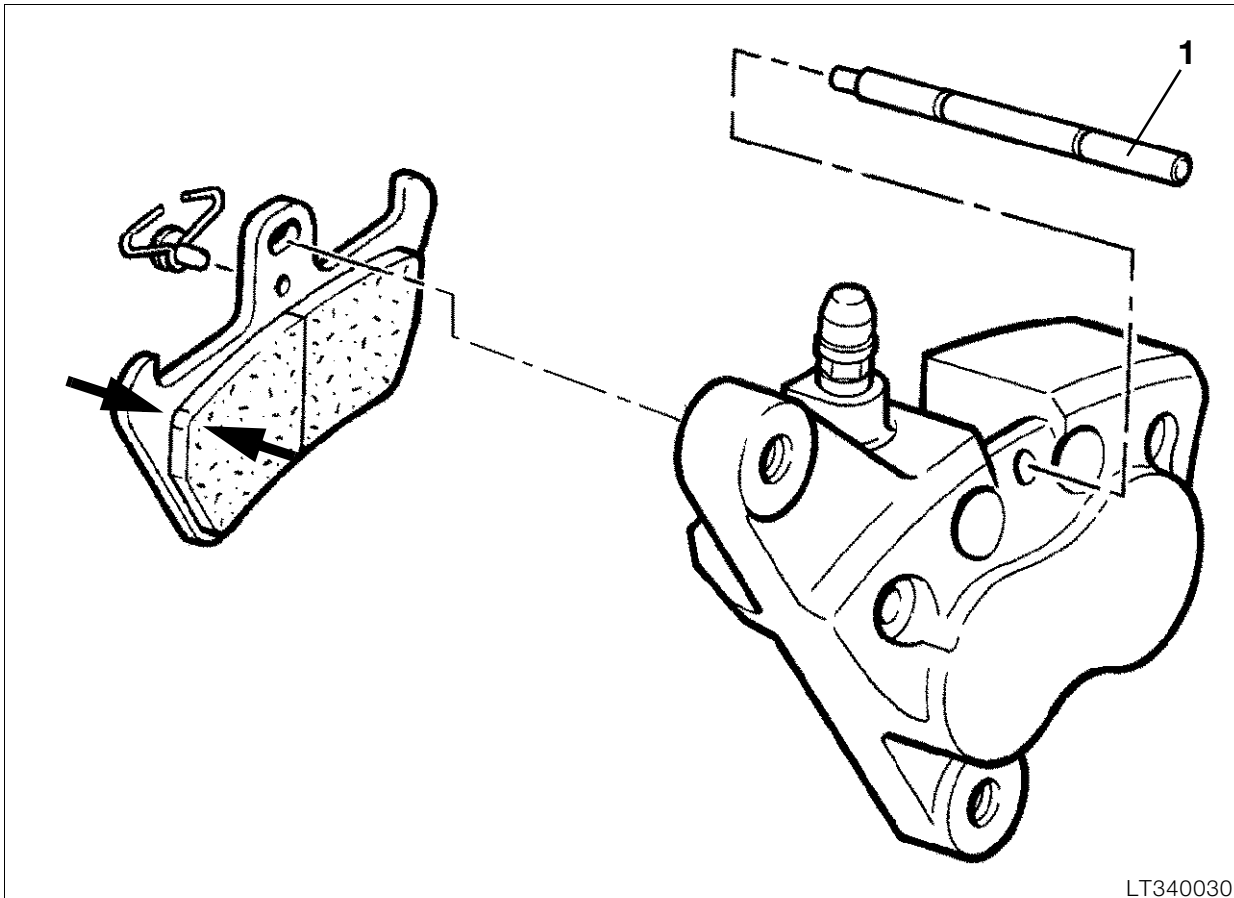
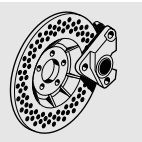

LT340030

Removing and installing brake pads

- Remove brake caliper.



Note:

If only the brake pads are to be replaced, do not release the brake line at the brake caliper.

- Drive out retaining pin (1).
- Remove brake pads by pulling downwards.



Caution:

Do not allow brake pads to wear down below the minimum thickness (arrow).
Replace pads only as complete set.

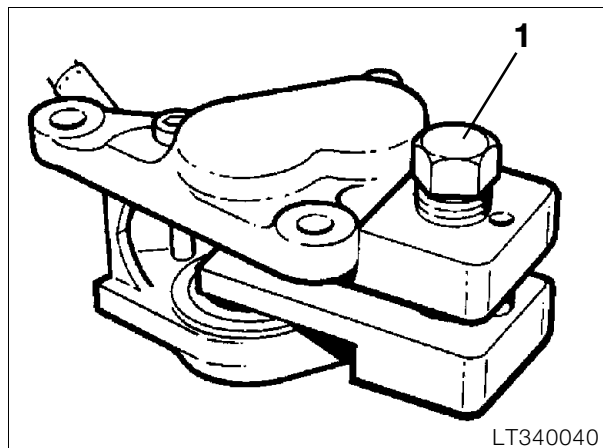

LT340040

Minimum brake pad thickness:

Thickness on carrier plate 1.5 mm

- Install in the reverse order of removal.



Note:

Before installing the brake pad, completely press back the pistons with the aid of the resetting tool (1),
BMW No. 34 1 500.

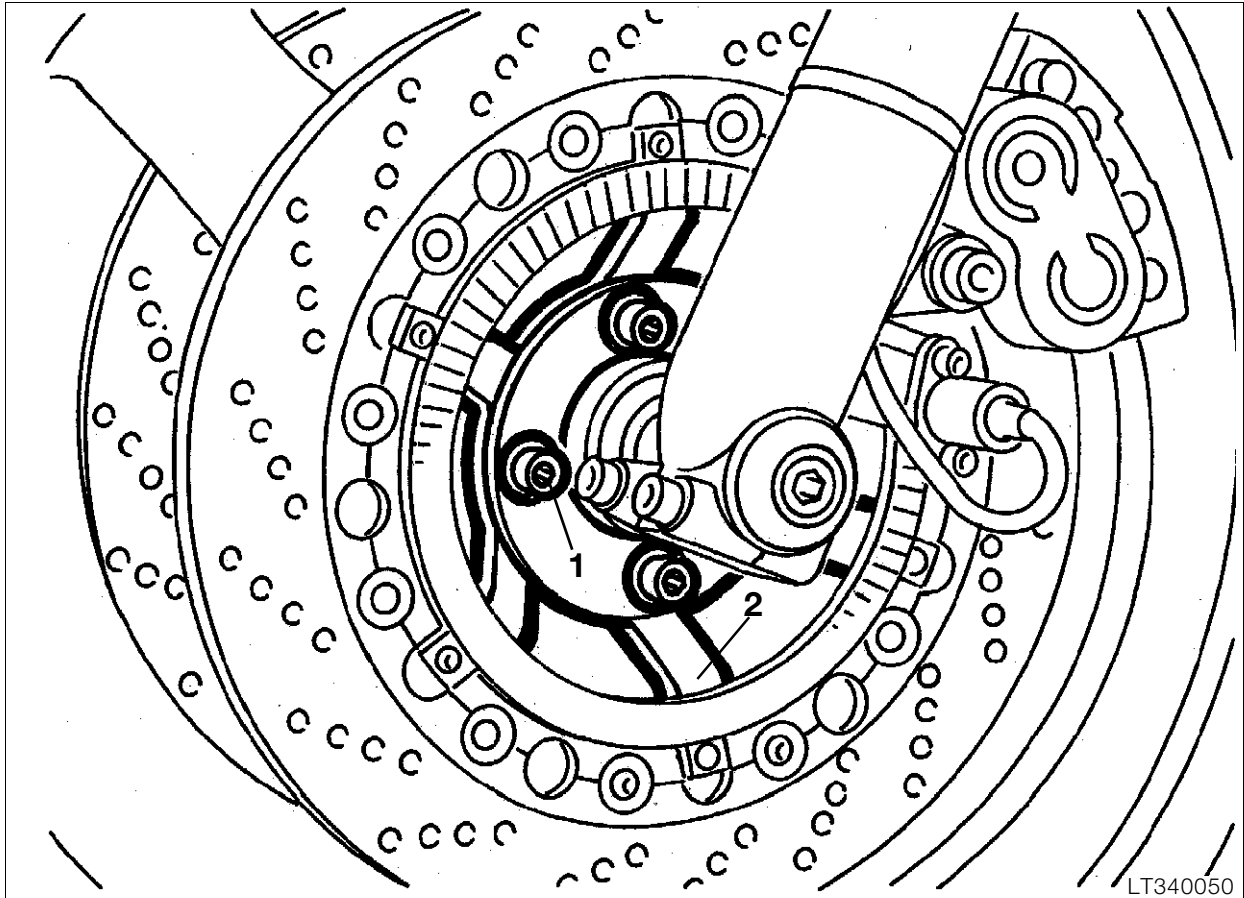

LT340050

Removing and installing front brake disc

- Remove front wheel.
- Release retaining screws (1) for brake disc carrier.
- Detach brake disc carrier (2) with brake disc.

Removing and installing ABS pulse wheel

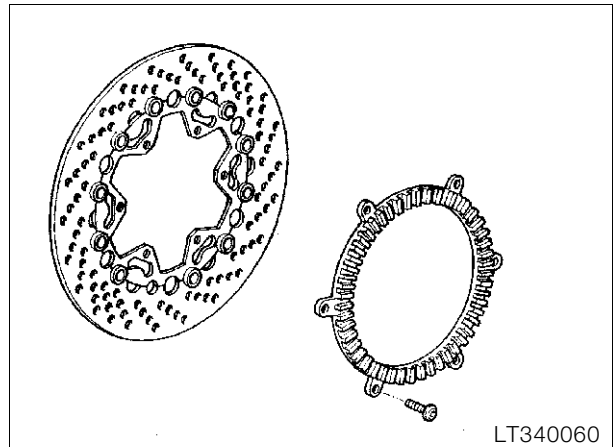

LT340060

- Release pulse wheel on brake disc carrier.

Tightening torque:
 Pulse wheel..... 4 Nm

Note:
 Before installing the pulse wheel, clean the micro-encapsulated screws and secure them with, for example, **Loctite 2701**.

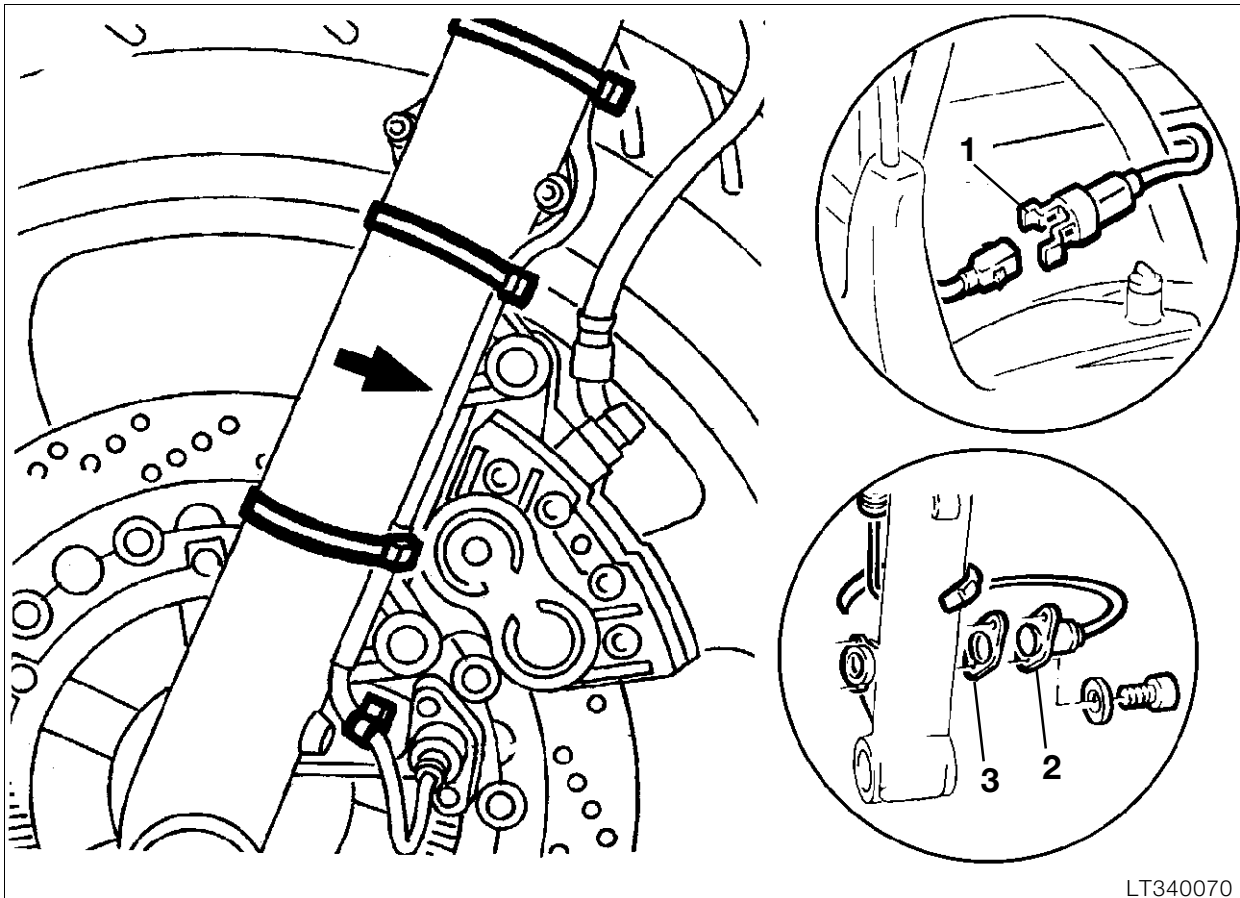

LT340070

Removing and installing front ABS sensor

- Remove fuel tank.
- Disconnect plug connection (1) of sensor line.
- Remove cover for brake distributor.
- Remove rear section of mudguard.
- Detach cable clips.
- Release sensor (2) with Torx socket, **BMW No. 34 2 500**.
- Install in the reverse order of removal.



Note:

Carefully install the sensor line (arrow), note position and number of cable clips and ensure tyre can turn smoothly.

Check sensor spacing where the gap is largest; if necessary readjust with spacer plate (3).

Sensor spacing

Up to 1996 MY 0.50 - 0.55 mm
 From 1997 MY 0.45 - 0.55 mm



Tightening torque:

Sensor to fork slider tube 4 Nm

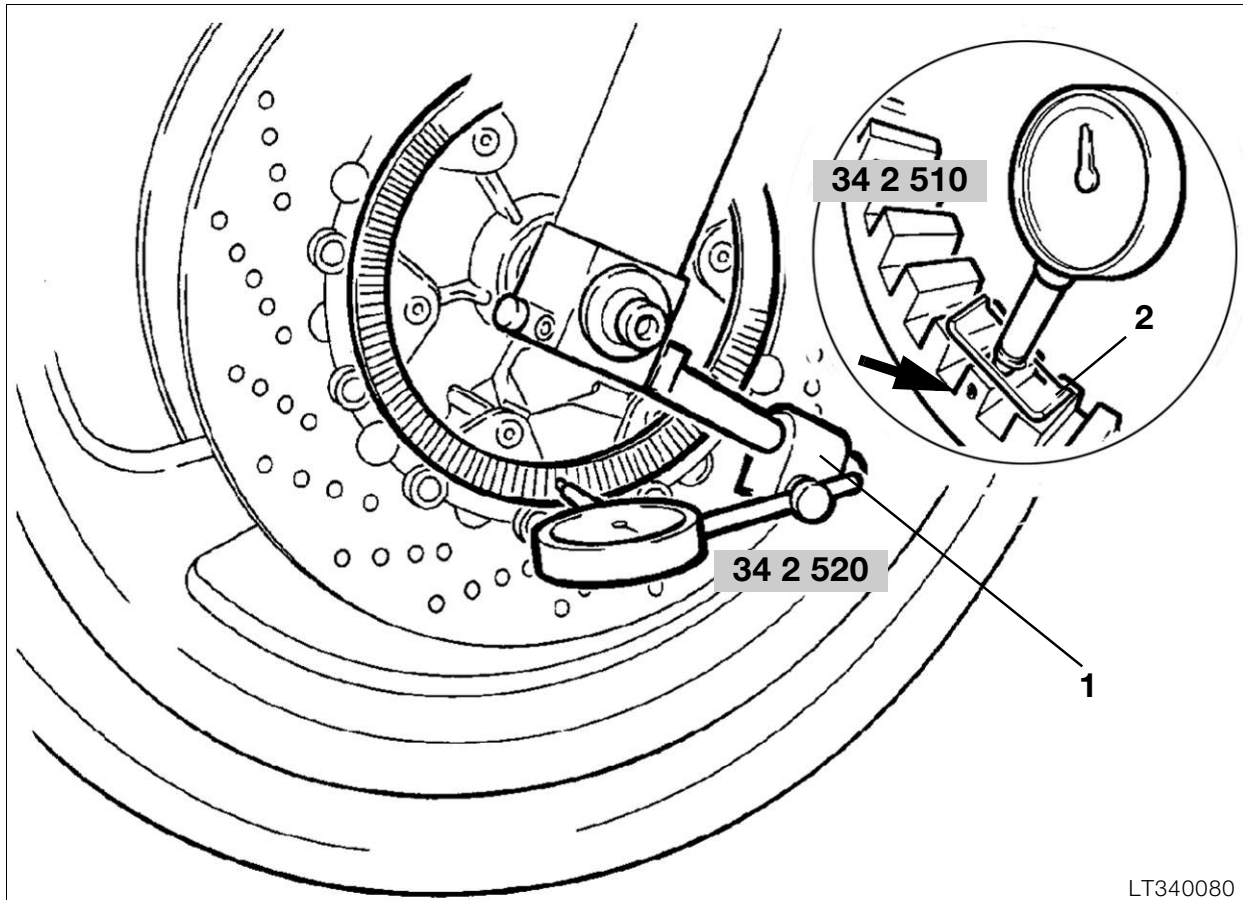

LT340080

Adjusting front ABS sensor gap

- Raise front wheel with front wheel stand, **BMW No. 36 3 950**.
- Secure dial gauge holder (1), **BMW No. 34 2 520** with dial gauge to fork sliding tube.
- Secure measuring shoe (2), **BMW No. 34 2 510** to feeler of dial gauge.
- Set dial gauge at marking (arrow) on pulse wheel to zero.
- Measure axial runout over the entire circumference.
- Adjust the sensor spacing with spacer plates at the point with the least pointer deflection.
- Remove and install sensor using Torx socket, **BMW No 34 2 500**.



Note:

If the pulse wheel has been replaced, its maximum axial runout must be determined; mark point with coloured dot.

Sensor spacing front:

Up to 1996 MY	0.50 - 0.55 mm
.....	(0.0197...0.0216 in)
From 1997 MY on	0.45 - 0.55 mm
.....	(0.0177...0.0216 in)



Caution:

After adjustment, check that the sensor is clear over the entire circumference.

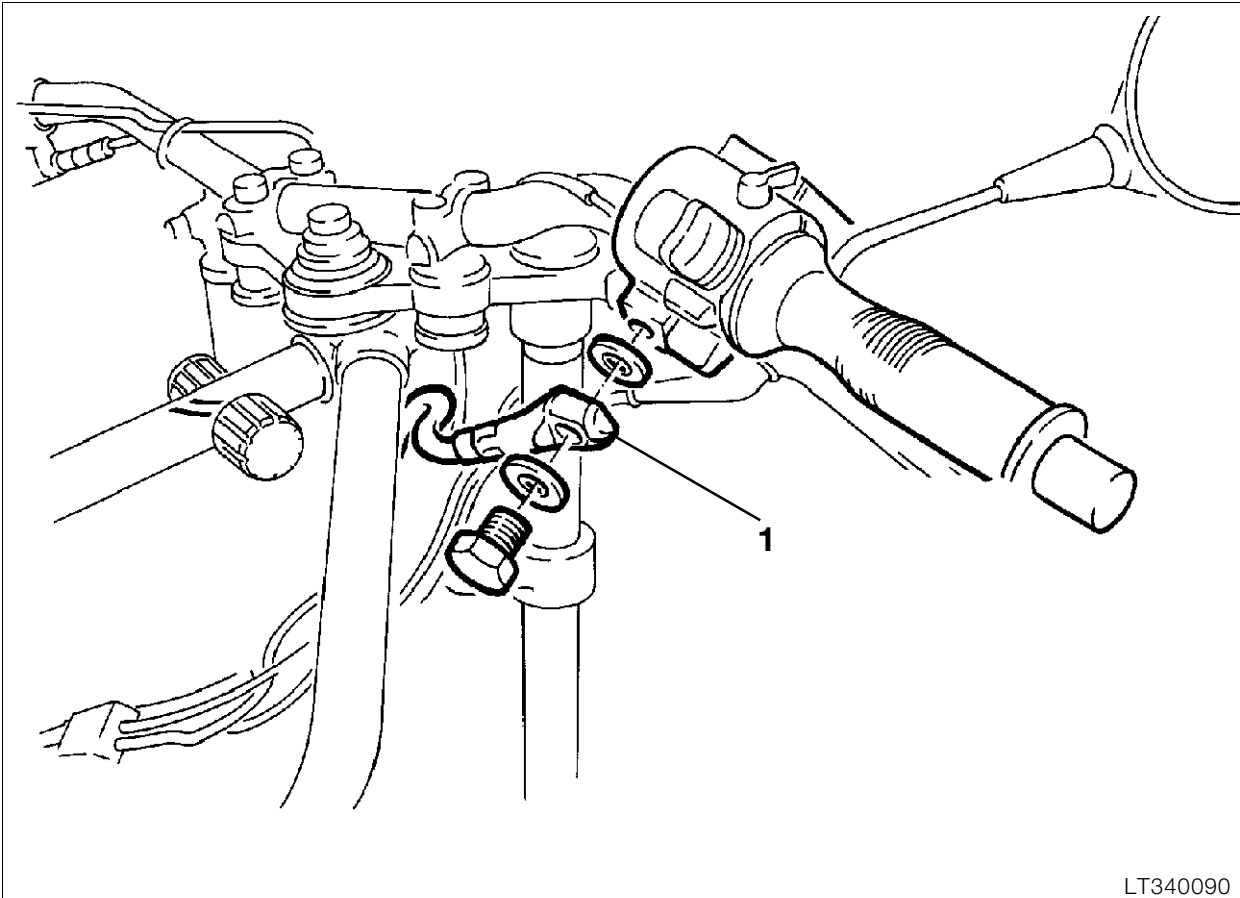

LT340090

Removing and installing front brake line

Removing upper brake line

- Drain brake system.
- Remove fuel tank.
- Release brake line (1) at handbrake cylinder.
- Remove cover for brake distributor on mudguard.
- Release brake line at the distributor.
- Install in the reverse order of removal.



Note:

Secure brake line to handbrake cylinder such that it does not chafe or kink when the handlebar is turned. Replace sealing rings of brake lines.



Caution:

Ensure brake fluid does not come in contact with painted parts of the vehicle; brake fluid destroys the paintwork.

Removing lower brake line

- Remove rear section of mudguard.

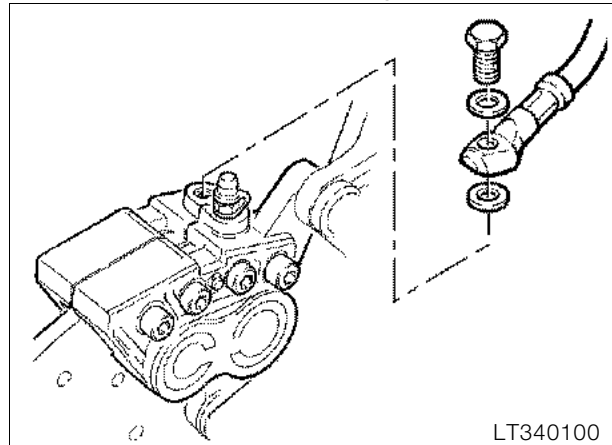

LT340100

- Release brake line at distributor and at the brake caliper.
- Install in the reverse order of removal.



Note:

Replace sealing rings of the brake lines.

- Carefully bleed brake system.



Tightening torques:

Brake line to handbrake cylinder	18 Nm
Brake line to distributor	18 Nm
Brake line to brake caliper.....	18 Nm
Bleed screw	14 Nm

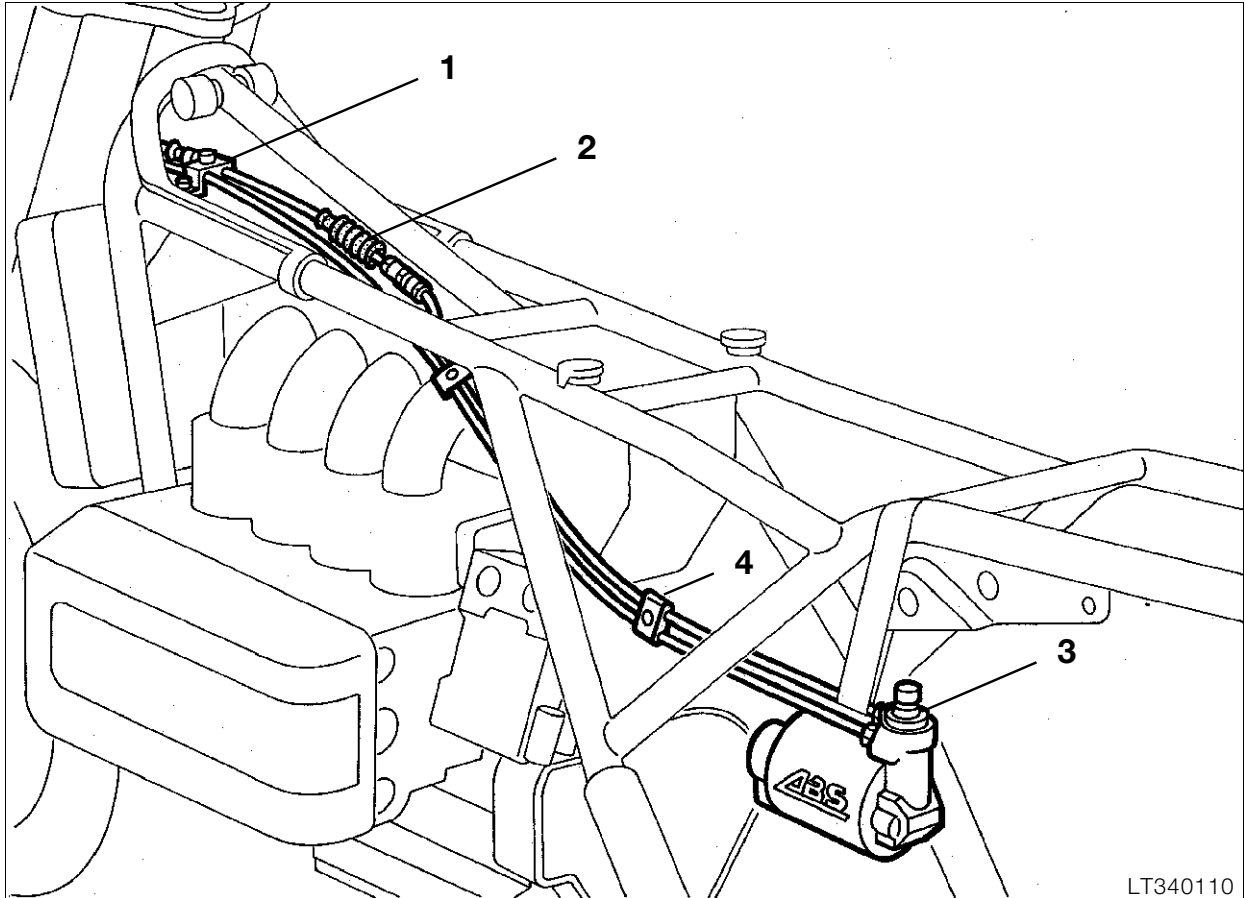

LT340110

Removing and installing ABS brake line from front pressure modulator

- Remove knee pads.
- Remove fuel tank.
- Release screw connections (1,2).
- Release connections at pressure modulator (3).
- Remove both lines together.
- Release spacer (4) and replace defective line.
- Install the reverse order of removal.

Tightening torques:

Screw connection 18 Nm
 Line to pressure modulator 18 Nm

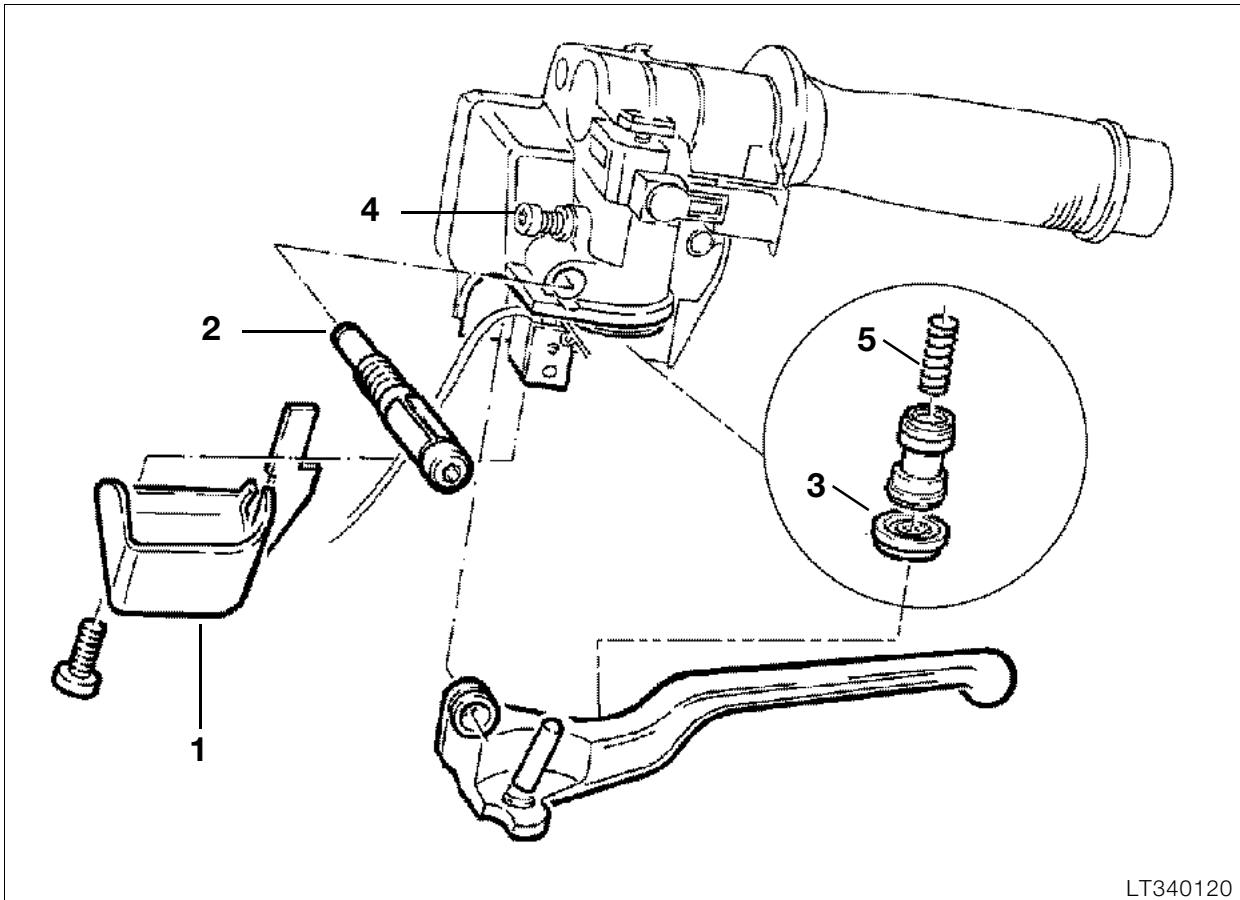

LT340120

Removing and installing handbrake cylinder

- Drain brake system.

Caution:

Ensure brake fluid does not come in contact with painted parts of the vehicle; brake fluid destroys the paintwork.

- Remove cover (1).
- Remove mounting pin (2) for handbrake lever.

Note:

The mounting pin is secured with Tuflok - blue. This screw fitting can be released and retightened several times.

- Carefully detach sealing sleeve (3).
- Press piston (3) a little way inward.
- Release stop screw (4).

Caution:

Piston is under spring loading.

- Relieve load on piston and remove together with spring (5).

- Check brake cylinder, piston and sealing rings.
- Install in the reverse order of removal.

Note:

The sealing lips of the piston must face inwards. Lightly grease thrust pin on handlebar lever with „Shell Retinax A“ or similar. Firmly tighten mounting pin (2) to specified torque. Coat stop screw (1) with **Loctite 270** and screw in until handlebar lever is free of play, then turn by a further half turn. Seal screw head with paint.

Tightening torque:

Mounting pin 8 Nm

Bleeding brake



Caution:
Escaping brake fluid can damage painted surfaces.

Bleeding front brake

Bleeding brake caliper

- Remove front brake pads.



Caution:
Do not tilt the brake caliper when removing or installing.
The brake disc could be damaged.

- Detach the cover from the brake fluid reservoir and remove it together with the diaphragm.
- Add brake fluid.



Caution:
When bleeding, brake fluid level must not be allowed to drop below the "MIN" mark, or else air will be drawn into the brake circuit.
If this happens, the bleeding procedure must be repeated.

- Connect a vessel to the brake caliper bleed screws to trap escaping brake fluid, then open the bleed screw by half a turn.

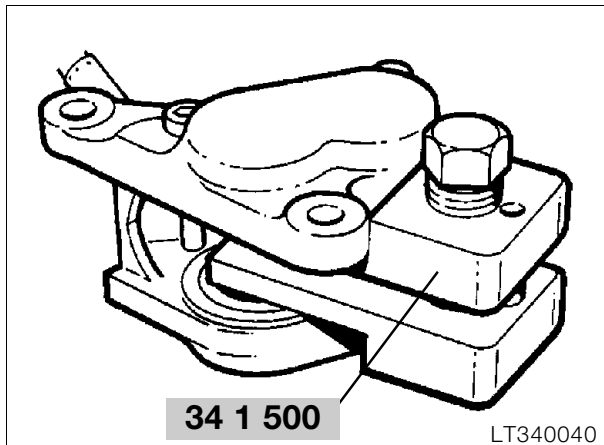

- Use piston resetting tool, **BMW No. 34 1 500**, to press the brake piston fully back.

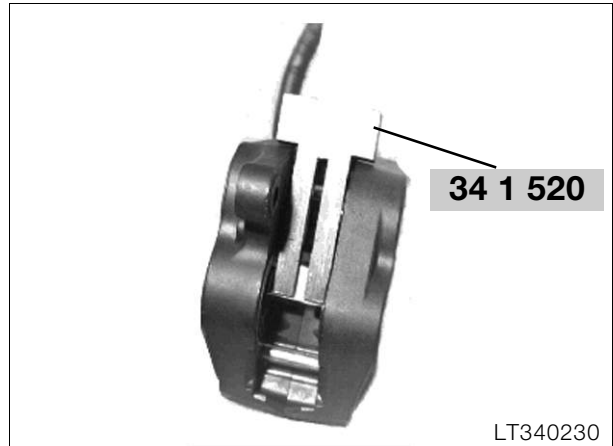

- Take out the piston resetting tool, insert spacer, **BMW No. 34 1 520**, and move it up to the brake disc.
- Press the piston back in the second brake caliper, but do not remove the piston resetting tool.
- Close the bleed screw.
- Pull in the handbrake lever several times until brake pressure is felt to build up.
- Maintain pressure at the handbrake lever and open the bleed screw, at the same time pulling the handbrake lever im firmly.



Caution:
Do not release the handbrake lever until the bleed screw has been closed.

- Close the bleed screw, then release the hand brake lever.
- Allow the brake fluid to emerge from both brake calipers until it is clear and free from bubbles.
- Close the bleed screws.
- Remove the spacer and the piston resetting tool.
- Install the brake pads/brake calipers.



Tightening torque:
Brake caliper to slider tube 40 Nm

[ABS II] Bleeding pressure modulator

- Remove the left battery cover.
- Connect a vessel to the brake caliper bleed screws to trap escaping brake fluid, then open the bleed screw by half a turn.
- Maintain pressure at the handbrake lever and open the bleed screw, at the same time pulling the hand brake lever in firmly.



Caution:

Do not release the handbrake lever until the bleed screw has been closed.

- Allow the brake fluid to emerge from both brake calipers until it is clear and free from bubbles.
- Close the bleed screw while keeping the hand brake lever pulled in.

Bleeding the handlebar fitting

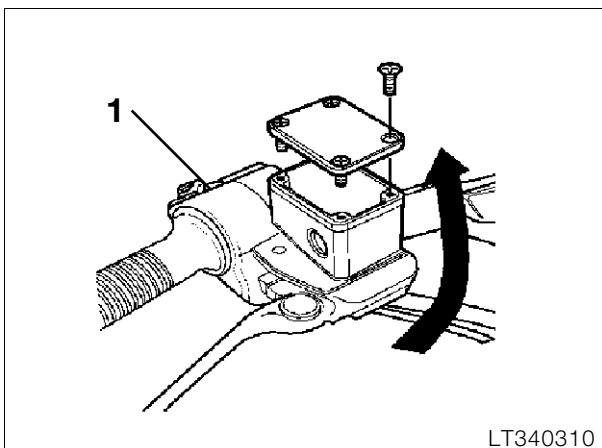

- Remove combined switch (1) from the right handlebar fitting.
- Remove clamping screw from handlebar fitting.
- Turn the brake fluid reservoir up round the handle bar (arrow) until the air escapes from the brake line.
- Turn the reservoir back down.
- Tighten the clamping screw on the handlebar fitting.



Note:

When adding brake fluid, note the thickness of the brake pads. Add brake fluid up to the „MAX“ mark if the pads are new.

- Add brake fluid.



Note:

When checking front brake fluid level, the brake fluid reservoir must always be in a horizontal position.

- Replace the diaphragm and reservoir cover in position.
- Tighten the retaining screws without using force.
- Check brake operation.
- Install the combined switch.

Bleeding rear brake

Bleeding brake caliper

- The rear brake caliper does not have to be removed, nor the pistons pressed back.
- The remaining procedure is the same as when bleeding the front brake circuit.



Tightening torque:

Brake caliper to rear wheel drive 40 Nm

[ABS II] Bleeding pressure modulator

- Follow the same procedure as when bleeding the front brake circuit.

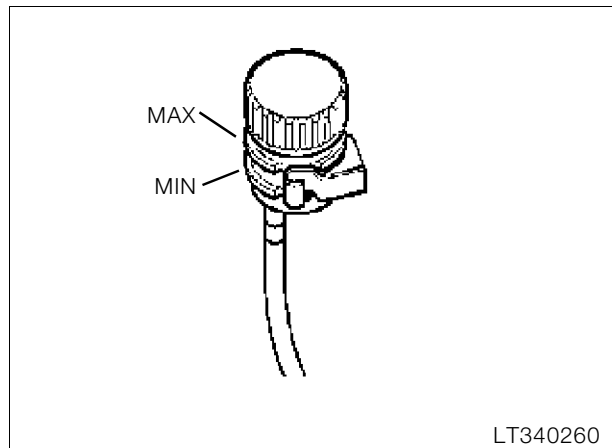

Note:

When adding brake fluid, note brake pad thickness. Add brake fluid up to the „MAX“ mark with new pads.

- Add brake fluid.
- Replace the diaphragm and reservoir cover in position.
- Check that the brake is operating correctly.

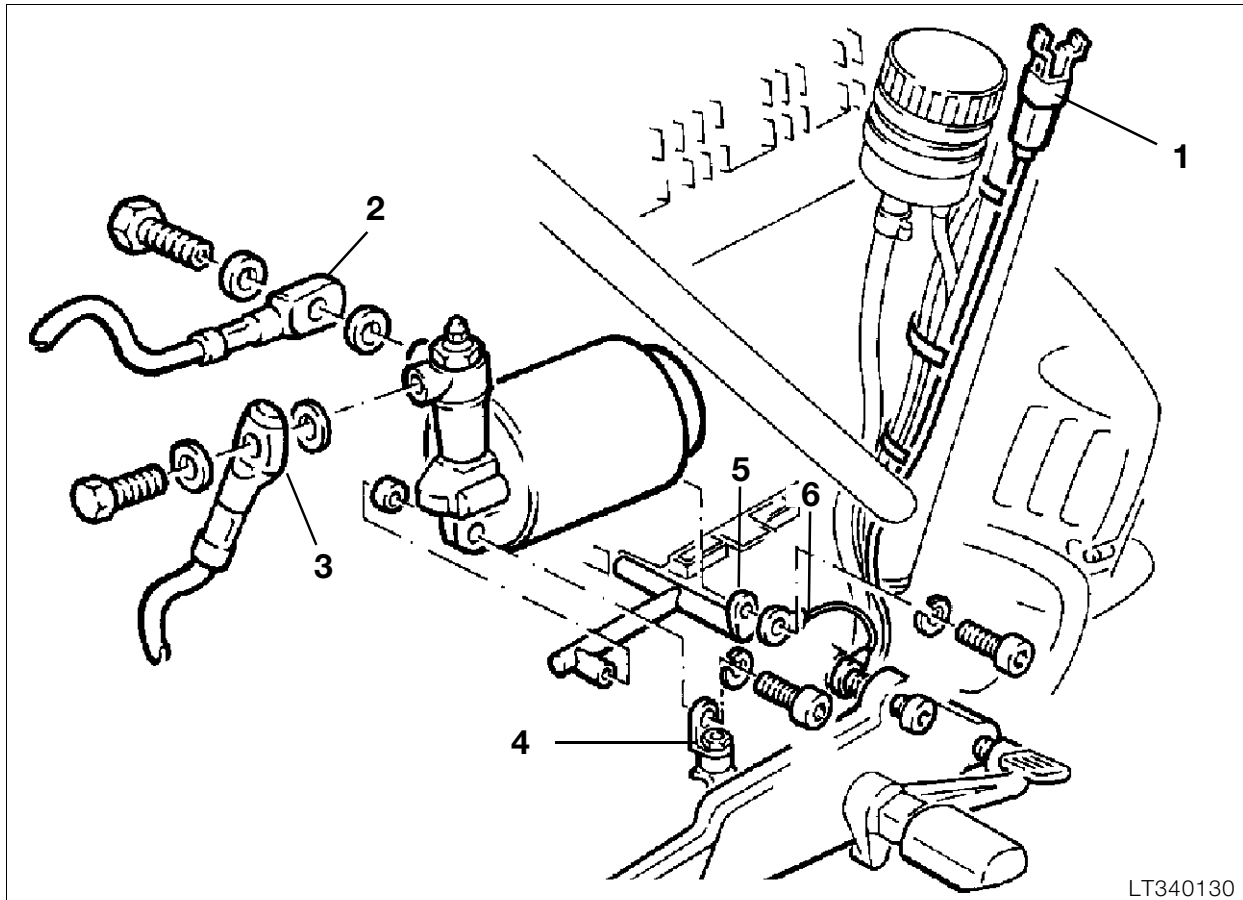

LT340130

Removing and installing pressure modulator



Caution:

Work on the ABS unit is only to be carried out by an authorised BMW workshop.

- Detach the pressure modulator at silentbloc mount (4) and at the holder.
- Note earth (ground) wire (6).
- Install in the reverse order of work.
- Restore the correct brake fluid level and bleed the brake system.

[ABS I] Removing and installing front or rear pressure modulator

- Remove the fuel tank.
- Separate plug connector (1) (blue) for the pressure modulator.
- Clean the hydraulic pump assembly and the brake lines.
- Detach brake lines (2/3) at the pressure modulator and seal/cover them.



Caution:

Escaping brake fluid will damage painted surfaces.

Tightening torques:

Pressure modulator to holder.....	17 Nm
Brake line.....	18 Nm

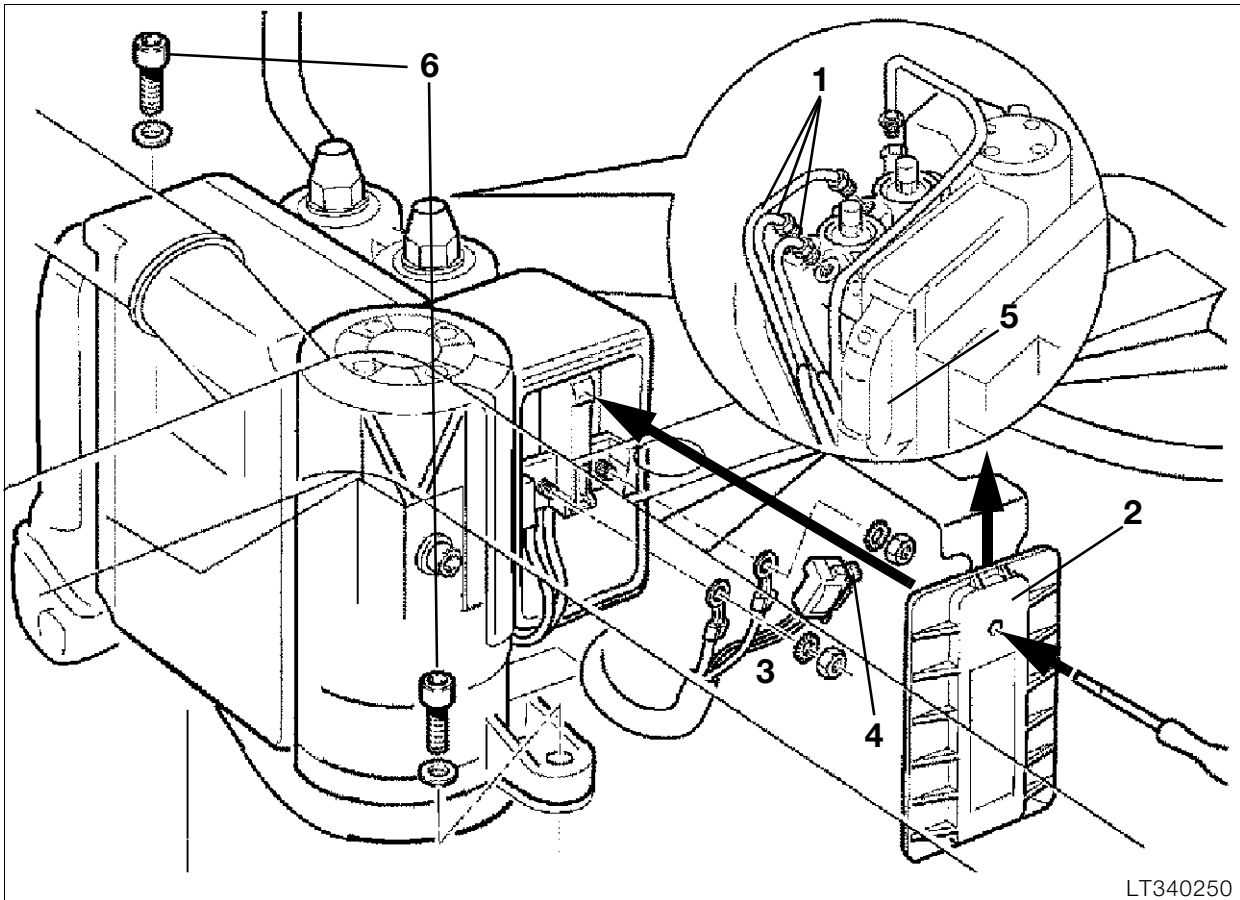

LT340250

[ABS II] Removing ABS unit

- Remove the dual seat.
- Remove the left and right battery trim panels.
- Remove the Motronic control unit.
- Remove the battery.
- Remove the coolant level equalising tank.
- Take off the lower section of the front mudguard.
- Drain the front and rear brake circuits.
- Secure the front brake lever to the handlebar with a rubber band (so that the fluid replenishing bore is close).
- Release cover (2) on the pressure modulator with a suitable centre punche or screwdriver, and pull off upwards.
- Detach the lines.
- Pull off 2-pin plug (4).
- Pull off central plug (5).
- Remove ABS unit (6).



Caution:

Escaping brake fluid causes damage to painted surfaces.

- Detach ABS brake lines (1) from the ABS unit.



Caution:

To avoid leaks caused by particles of dirt penetrating the brake system, clean the hydraulic pump assembly and the brake lines before detaching them. If appropriate, cover or seal the line unions.

[ABS II] Installing ABS unit

- Install ABS unit (6).
- Reconnect central plug (5).



Caution:

Do not tilt the cables or the insulation may be damaged.

- Push 2-pin plug (4) on correctly and as far as it will do, then press the two wires into the centre (smaller) cable entries.
- Attach both plugs of the connecting cable/wiring harness to the threaded pins with the crimp facing forwards.
- Press the cables into the remaining cable guides.
- Tighten the nuts.



Caution:

Use new self-locking nuts.



Tightening torques:

Battery -/M5..... 3.5 Nm
Battery +/M5 3 Nm

- Fit a new cover.



Caution:

When sliding on, make sure that all cables are positioned correctly in their guides.

Always use a new cover.

The old cover must be **scrapped**.

- Screw ABS brake lines (1) firmly to the ABS unit.
- Fill/bleed the brake system.
- Install the coolant level equalising tank.
- Install the battery.
- Install the Motronic control unit.
- Install the battery covers.
- Install the fuel tank.



Tightening torques:

ABS unit to mounting
M6 screw 9 Nm
Brake line to ABS unit 18 Nm
Bleed screw at ABS unit..... 9 Nm

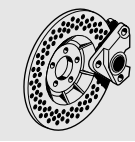

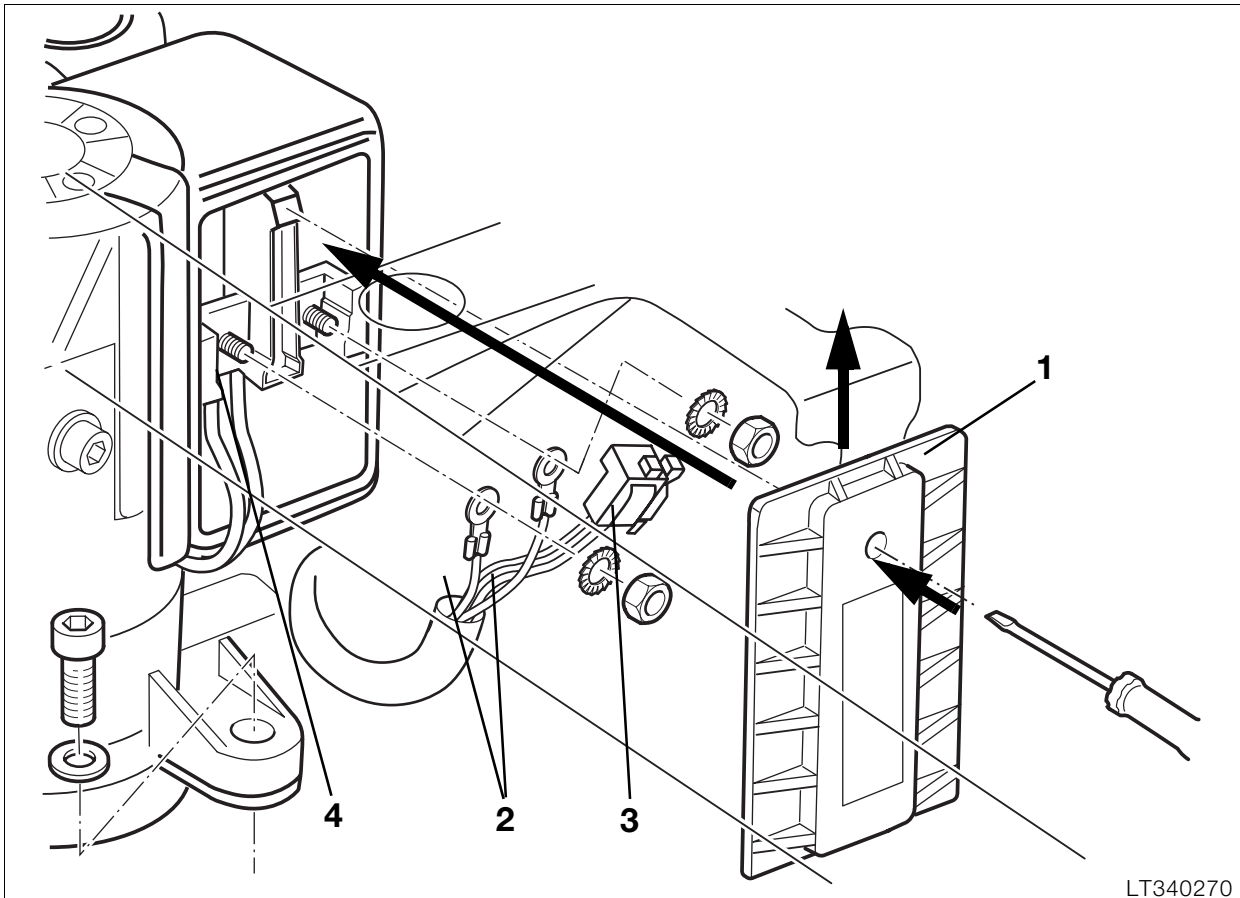

LT340270

[ABS II] Removing and installing relay and relay base

[ABS II] Removing relay

⚠ Caution:

Switch off the ignition and disconnect and insulate the earth (ground) lead.

- Remove cover (1) from ABS control unit, press the catch in with a screwdriver and pull the cover off upwards.
- Cover (1) must be **scrapped**.
- Disconnect wires (2) and **scrap** the retaining nuts.

⚠ Caution:

Do not tilt the cables or the insulation may be damaged.

- Pull off the 2-pin plug.
- Take out relay base (4).
- **Loosen** the screws at the relay base by app. 2 turns with a **Torx T20 screwdriver**.
- Pull the relay off upwards.

[ABS II] Installing relay

- Insert ABS relay with FAG logo in the direction of the retaining hook.
- Tighten the screws at the relay base.
- Push the relay base into the relay housing, at the same time pressing both engine wires into the left relay housing cable guide (red at bottom, black at top).
- Attach black cable to left threaded pin (M5) with the crimp facing to the rear.

⚠ Caution:

Do not tilt the cable or the insulation may be damaged.

- Push the 2-pin plug fully on in the correct position and press the two wires into the centre (smaller) cable guides.
- Attach both connecting lead/wiring harness plugs to the threaded pins with the crimp facing forwards.
- Press both leads into the remaining cable guides.
- Tighten the nuts.

⚠ Caution:

Always use new self-locking nuts.

- Install a new cover (1).

**Caution:**

When pushing on, make sur that all cables are correctly located in their guides.
Scrap the old cover.

[ABS II] Removing relay base

**Caution:**

Switch off the ignition and disconnect and insulate the earth (ground) lead.

- Remove cover (1) from ABS control unit, press in the catch with a screwdriver and pull the cover off upwards.
- **Scrap** the cover.
- Disconnect leads (2) and **scrap** the nuts.

**Caution:**

Do not tilt the cables or the insulation may be damaged.

- Pull off the 2-pin plug.
- Take out relay base (4).
- Take out screws on relay base with a **Torx T20 screwdriver**.
- Remove the ABS relay
- Press the contact lock out of the relay base.
- Using the special tool, **Article No. 50000-017-507 from the Grote und Hartmann company**, insert the plug from the relay side.

**Caution:**

The contact has a double locking action.
When pulling the plug out of the relay base, do not exert too much tension on the cable.
If the cable breaks off, the complete ABS will have to be renewed.

[ABS II] Installing relay base

- Ben up the contact lock for the plug.
- Insert the contact into the relay base.

**Caution:**

The contact must be heard to engage, and must be firmly seated.

- Insert ABS relay with FAG logo in the direction of the retaining hook.
- Insert one Torx screw into the ring cable shoe on the red engine lead.

**Note:**

The crimp side must face toward the screw head.

**Caution:**

The same Torx screws must be used because of their self-locking acition. When inserting, make sure that the thread already present in the sheet metal is entered again.

Failing this, the screws could come loose when exposed to vibration.

- Place the ring cable shoe (with two leads) on the hole in the insert on the rear of the relay base, with the crimped side facing the relay base, and screw on together with the red engine lead, using a Torx screw.
- With the second Torx screw, attach the flat plug to the relay.
- Press the contact lock into the relay base at the side.
- Push the relay base into the relay housing and at the same time press both engine leads into the left cable guide on the relay housing (red at bottom, black at top).
- Place the black engine lead on the left threaded pin (M5) with the crimp facing to the rear.

**Caution:**

Do not tilt the cable, or the insulation may be damaged.

- Attach the 2-pin plug in the correct position and push on as far as it will go, at the same time pressing the two leads into the centre (smaller) cable guides.
- Place both plugs of the connecting lead/wiring harness on to the threaded pins with the crimp facing forwards.
- Press both leads into the remaining unoccupied cable guides.
- Tighten the nuts.

**Caution:**

Always use new self-locking nuts.

- Install a new cover (1).

**Caution:**

When sliding into position, make sure that all cables are in the correct guides.

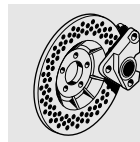

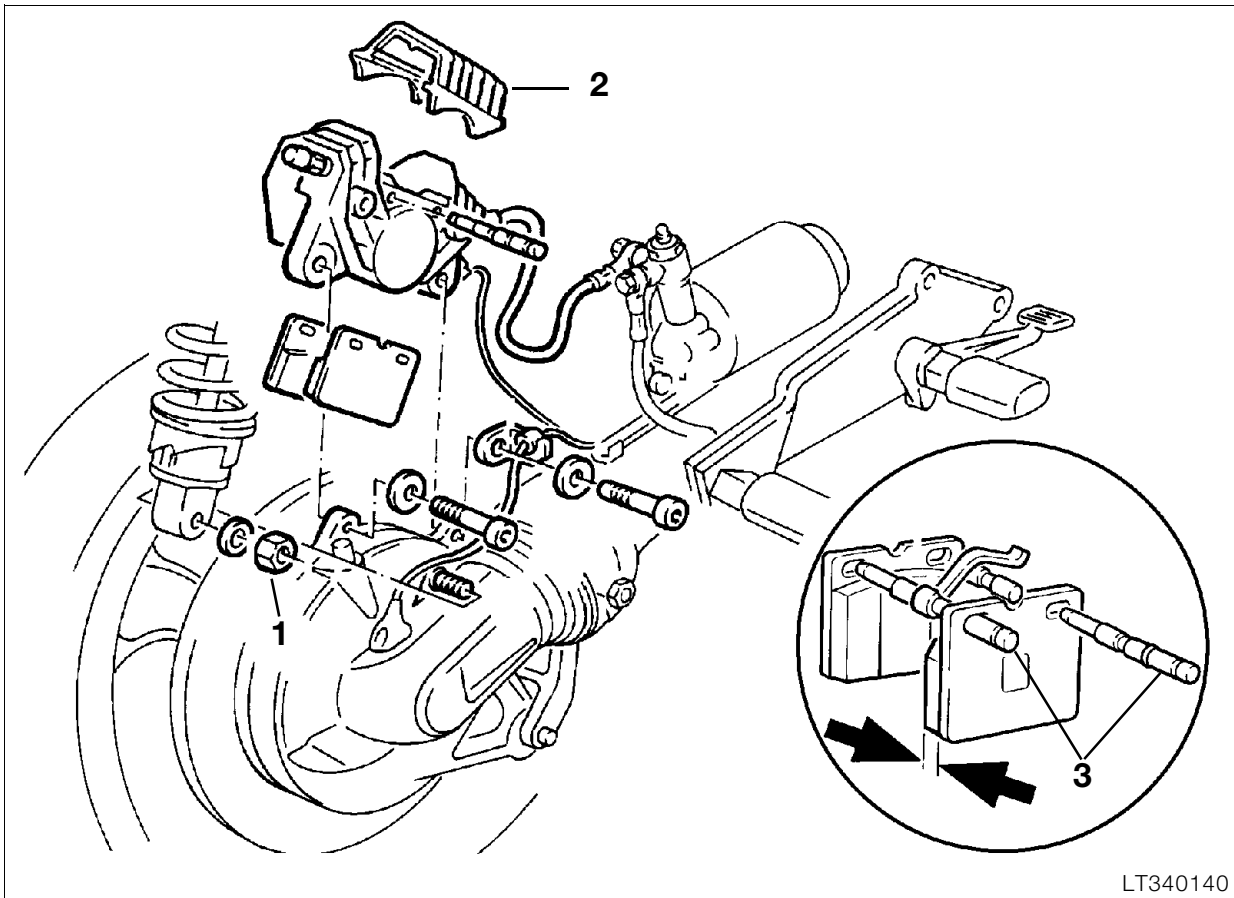

LT340140

Removing and installing rear brake caliper

- Drain brake System.
- Release bottom of suspension strut (1).
- Detach suspensions strut from stud bolt.
- Release brake line at brake caliper.
- Disconnect ABS plug connection for sensor line.
- Release brake caliper and carefully lift out.
- Install in the reverse order of removal.

- With the aid of a drift, drive out retaining pins (3) from the wheel side.
- Remove brake pads by pulling upward.
- Install in the reverse order of removal.

Minimum brake pad thickness 1.5 mm



Note:

Replace sealing rings of brake lines.



Caution:

Ensure brake fluid does not come in contact with painted parts of vehicle; brake fluid destroys the paintwork.

Check ABS sensor spacing, if necessary readjust with spacer plates.

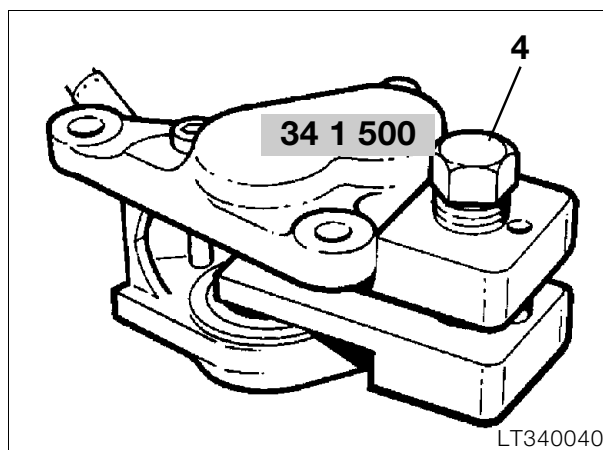

LT340040



Sensor spacing rear:

Up to 1996 MY 0.60 - 0.65 mm
 (0.0236...0.0256 in)
 From 1997 MY on 0.45 - 0.55 mm
 (0.0177...0.0216 in)



Note:

Before installing the new brake pads, press back pinion in brake caliper with the aid of the piston resetting tool (4), **BMW No. 34 1 500**.

Removing and installing rear brake pads

- Remove cap (2).



Caution:

Carefully bleed brake system!

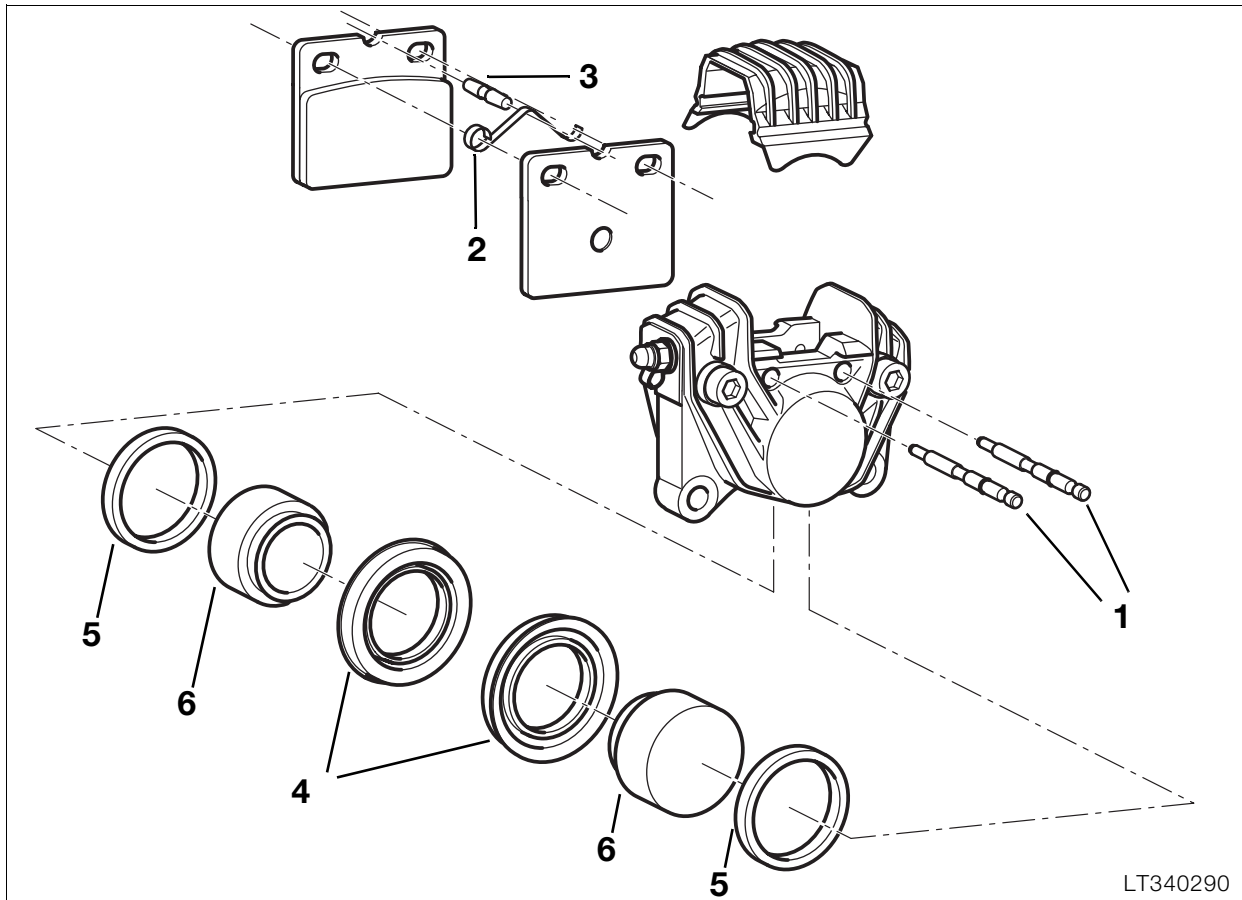

Dismantling and assembling rear brake caliper

Dismantling rear brake caliper

- Remove keepers (1).
- Drive out spring (2) and retaining pin (3).
- Take out brake pads.
- Seal the bleed screw.

Tightening torque:

Bleed screw at brake caliper rear 11 Nm

- Remove sealing rings (4) from left/right cylinder.



Caution:

Keep fingers away from gap between pistons and side contact face of brake pads; risk of injury!
If necessary press back with screwdriver carefully.

- Hold a cloth over the brake caliper piston.
- **Carefully** press out brake piston (6) with a compressed air gun applied to the connecting bore; work at low air pressure.
- Remove sealing rings (5) from left/right cylinder hole.

Assembling rear brake caliper

- Coat the new sealing rings with brake fluid and insert them into the left/right brake caliper cylinders.



Caution:

Do not tilt the brake pistons when installing.

- Coat both brake caliper pistons with brake fluid and install them.



Note:

The installed position must be correct!

- Insert brake pads and secure with retainers.

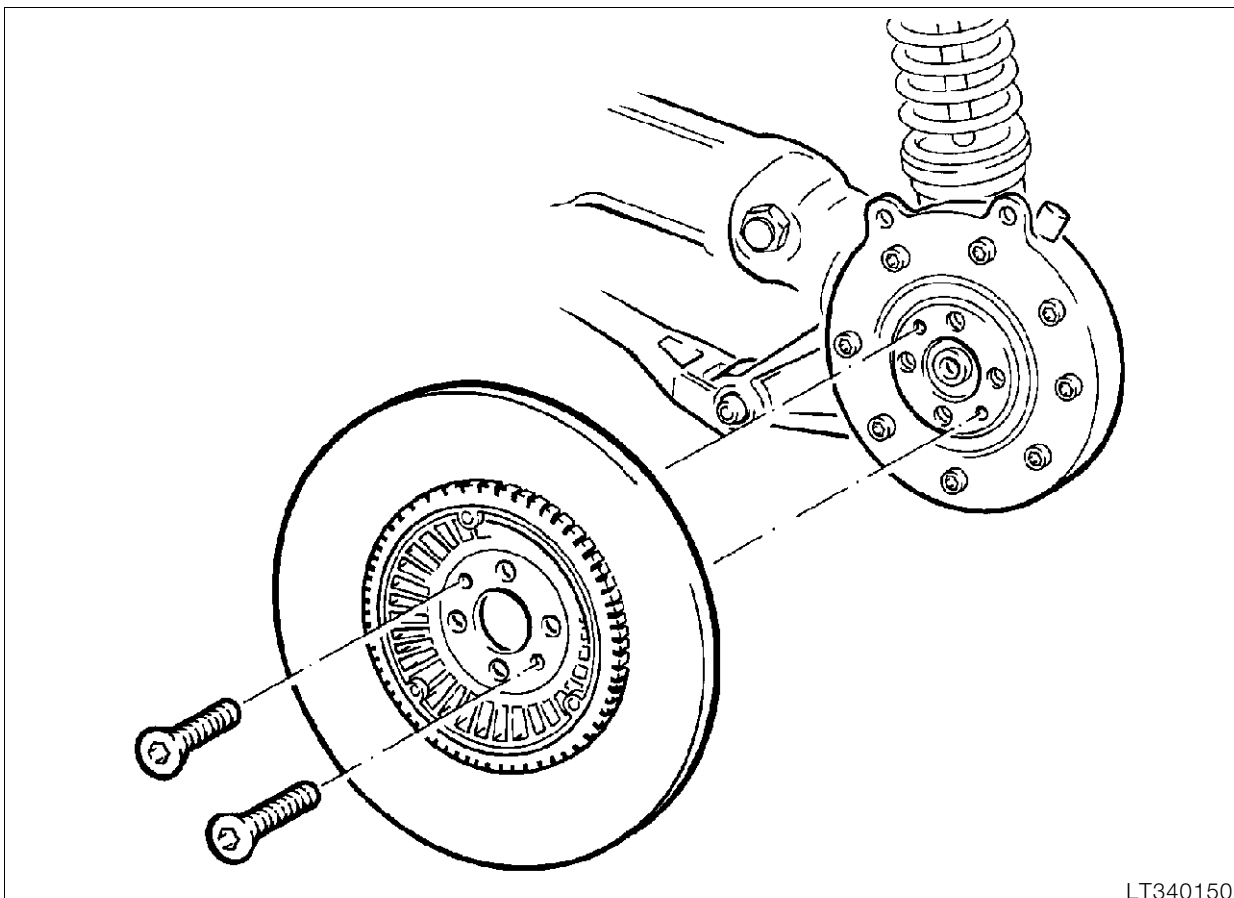
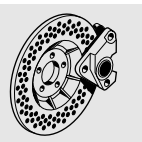

LT340150

Removing and installing rear brake disc

- Remove brake caliper.
- Remove rear wheel.
- Remove brake disc.



Note:

Mark installation position of the brake disc so that the vertical runout of the pulse wheel is not changed.

- Install in the reverse order of removal.



Note:

Screw in retaining screws with **Loctite 270**.
Check ABS sensor spacing, if necessary adjust with spacer plates.



Tightening torque:

Brake disc carrier 21 Nm



Caution:

ABS - The vertical runout must be determined if the brake disc and therefore also the pulse wheel are replaced.

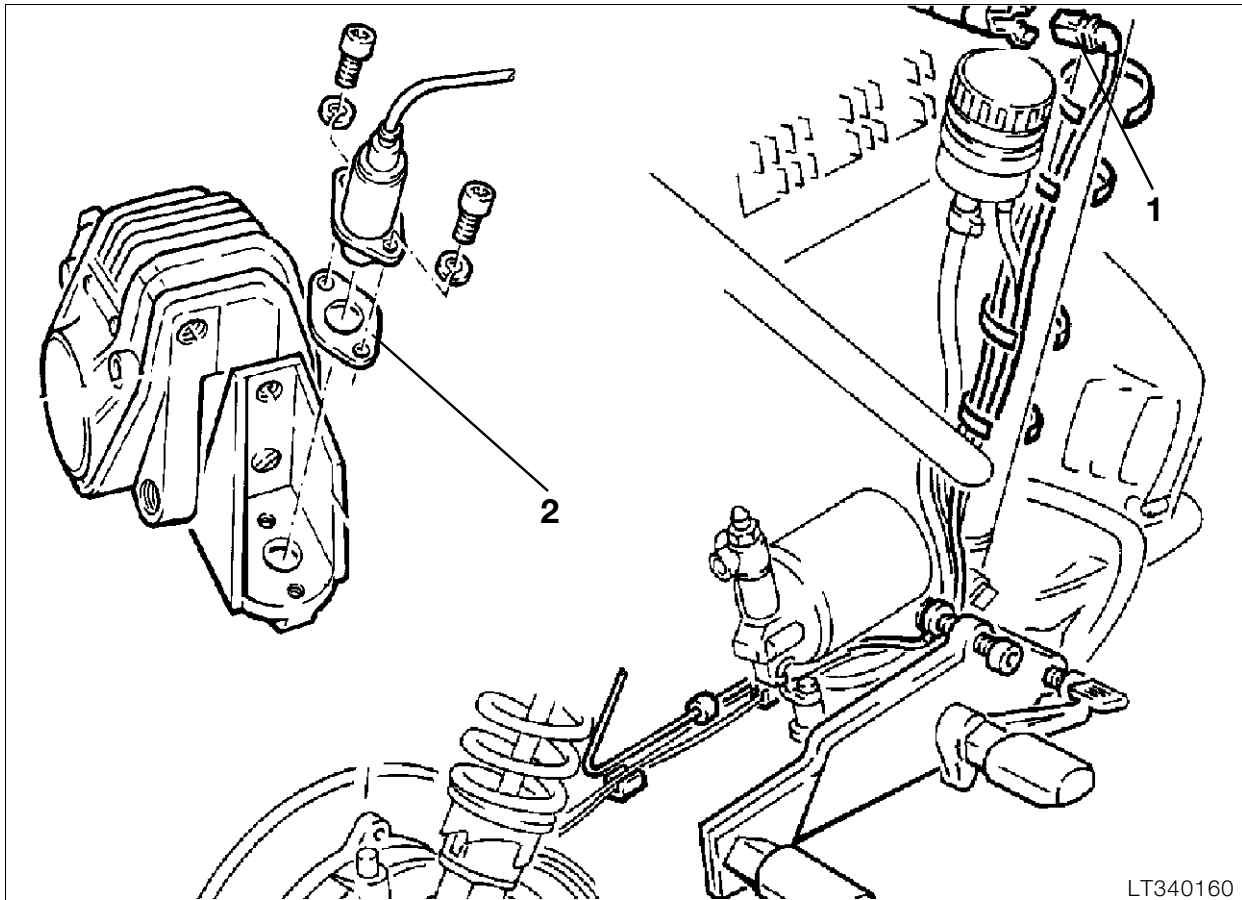

LT340160

Removing and installing rear ABS sensor

- Remove brake caliper but do not loosen brake line.
- Release sensor with socket wrench, **BMW No. 00 2 640**.
- Disconnect plug connection (1) for sensor line.
- Install in the reverse order of removal.



Caution:

Check sensor spacing where the gap is greatest; if necessary, adjust with spacer plates (3). Carefully lay sensor line.

Sensor gap

Up to 1996 model year.....	0.60 ... 0.65 mm
.....	(0.0236...0.0256 in)
From 1997 model year on	0.45 ... 0.55 mm
.....	(0.0177...0.0216 in)



Tightening torque:

Sensor 4 Nm

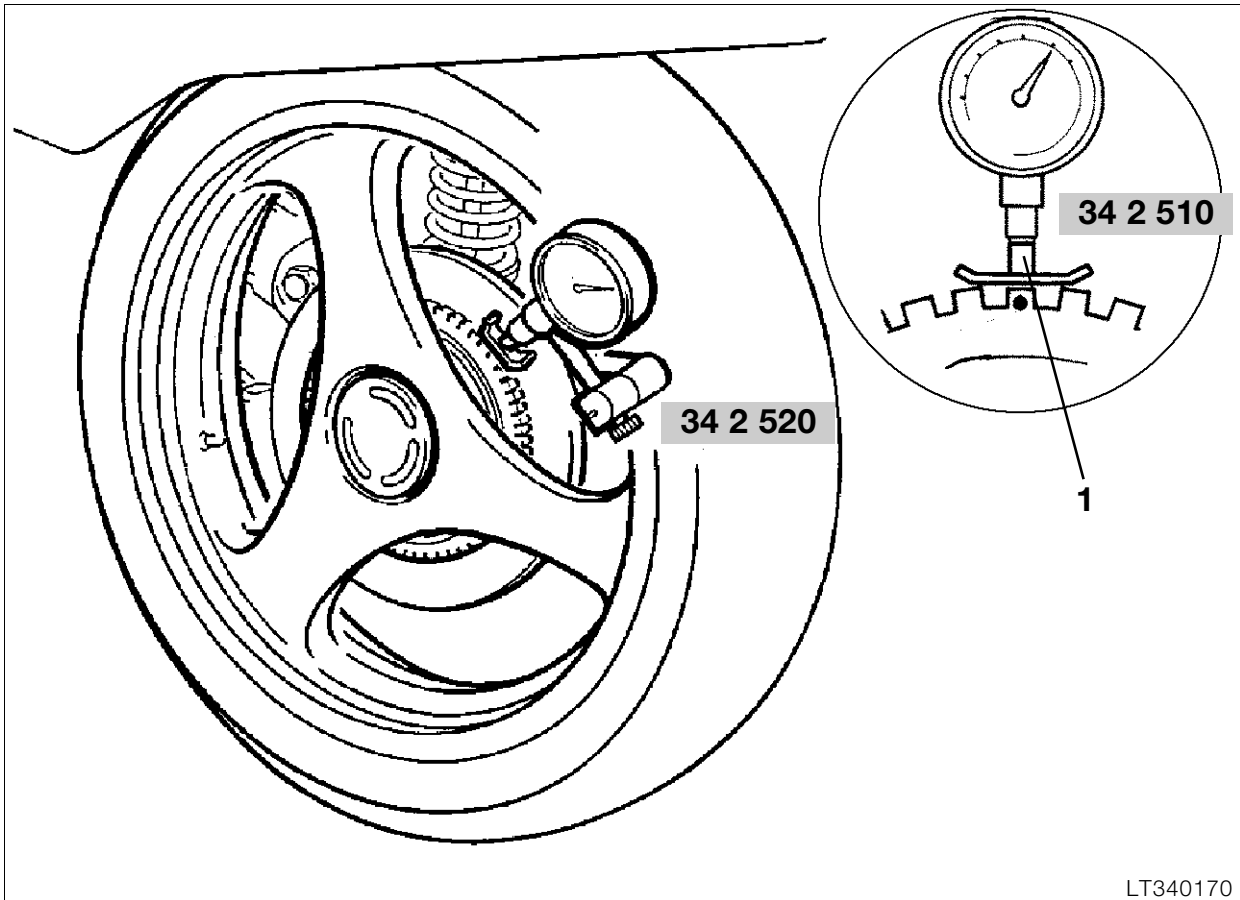

LT340170

Measuring vertical runout at rear pulse wheel

- Remove brake caliper.
- Remove rear wheel.
- Secure dial gauge with retaining fixture to bottom of spring strut mounting.
- Position dial gauge with measuring shoe (1), **BMW No. 34 2 510**, on pulse wheel.
- Set dial gauge to zero.
- Measure vertical runout over the entire circumference.
- Mark the point with the least vertical runout with oil paint.
- Adjust the sensor spacing at this point.

Sensor spacing

Up to 1996 model year.....	0.60 ... 0,65 mm
.....	(0.0236...0.0256 in)
From 1997 model year on	0.45 ... 0.55 mm
.....	(0.0177...0.0216 in)

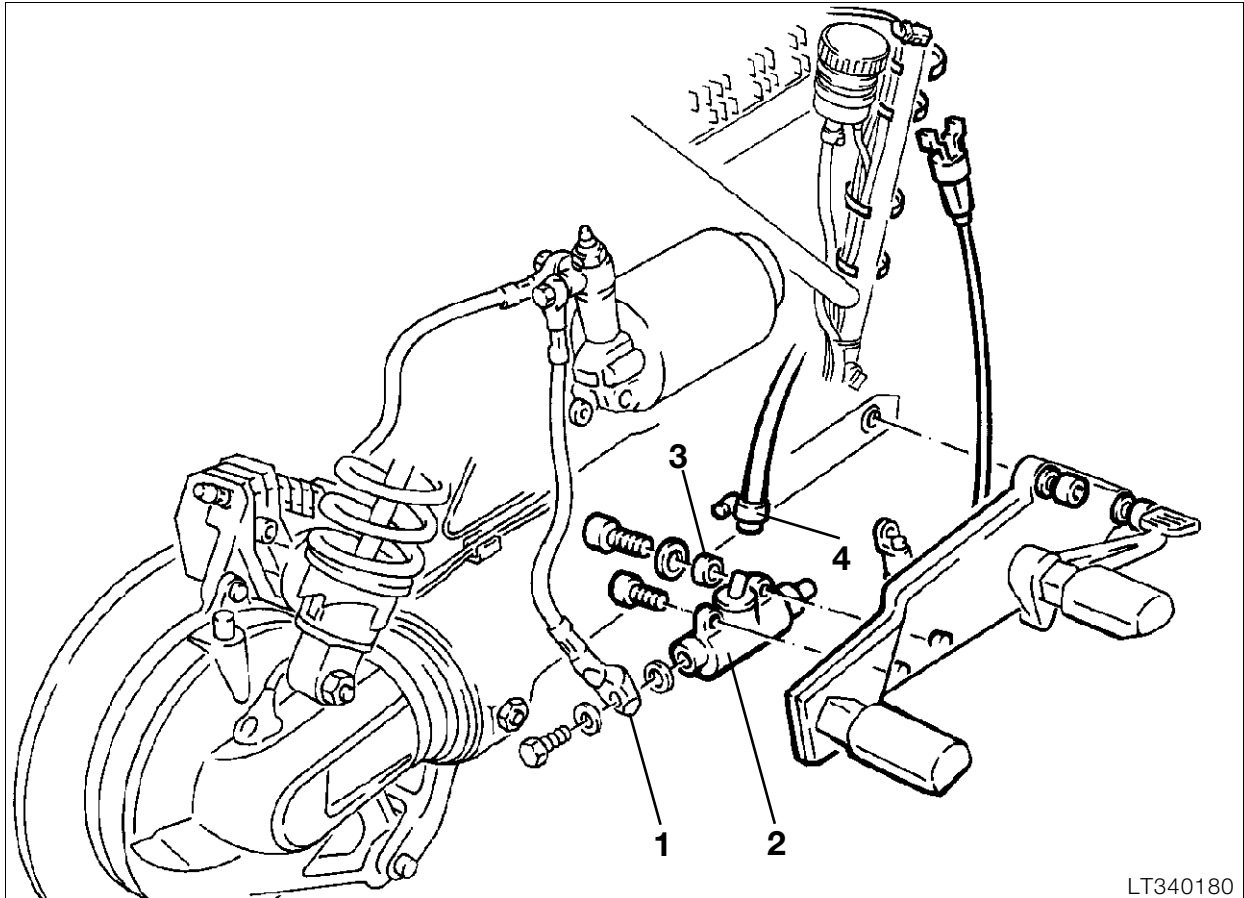

LT340180

Removing and installing rear master brake cylinder

- Drain brake system.

Caution:

Ensure brake fluid does not come in contact with painted parts of the vehicle; brake fluid destroys the paintwork.

- Release brake line (1) at master brake cylinder (2).
- Remove footrest plate.
- Release master brake cylinder (2).

- Note spacer sleeve (3); spring is under pressure.
- Open clip (4) on the supply line, detach line.
- Install in the reverse order of removal.

Caution:

Carefully bleed brake system.

Tightening torques:

Master brake cylinder..... 9 Nm
 Brake line to master brake cylinder 18 Nm

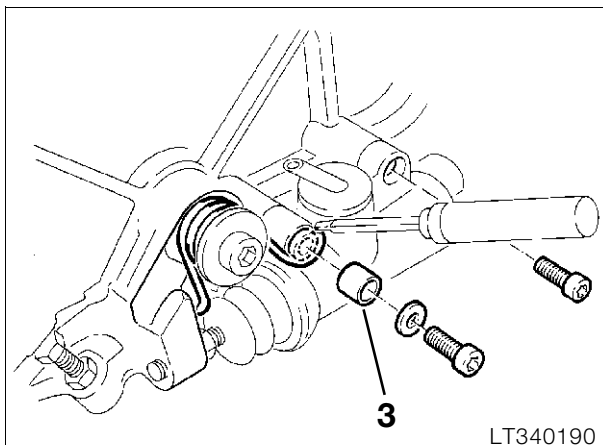

LT340190

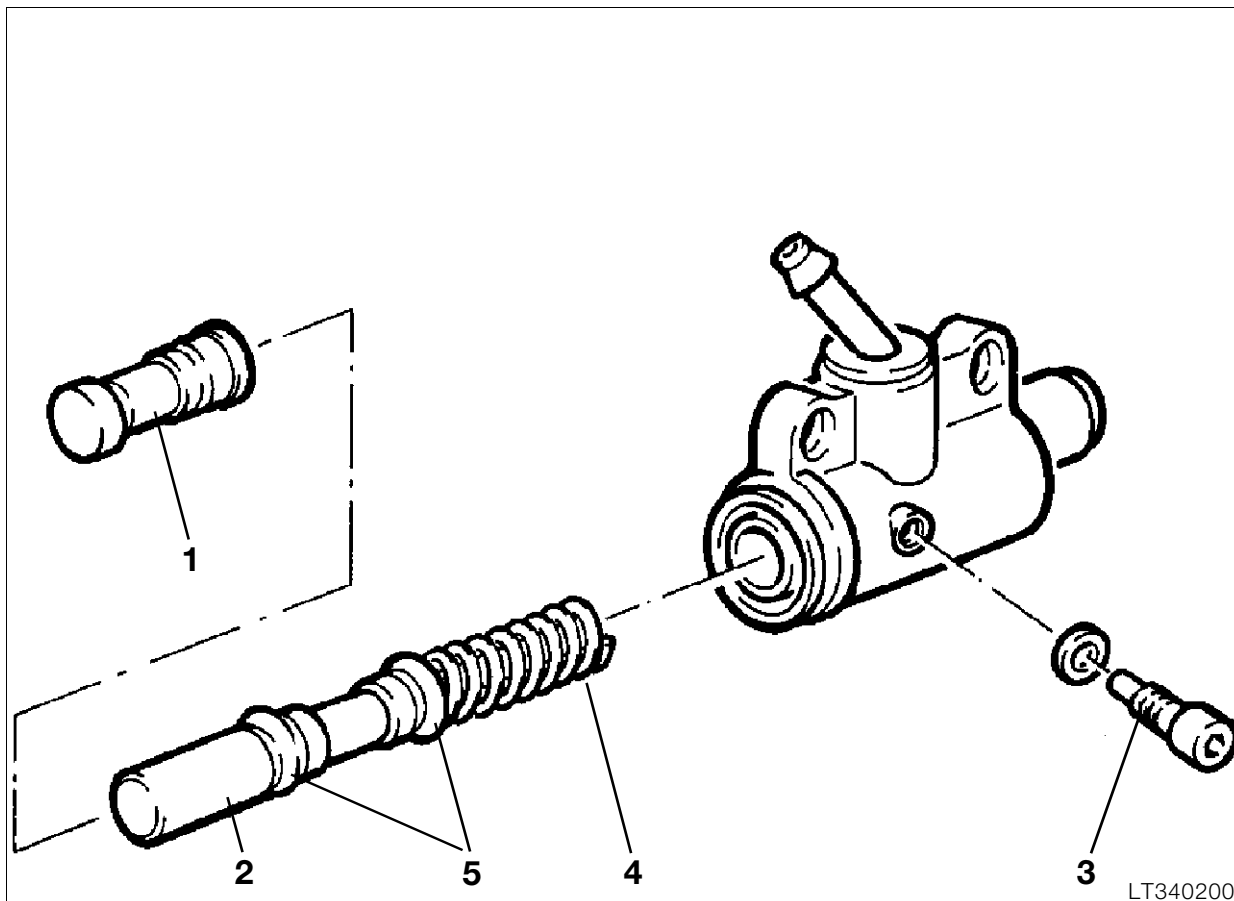
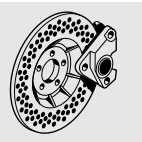

Disassembling rear master brake cylinder



Caution:

Piston is under spring loading.

- Using thrust piece (1), push piston (2) a little way inwards.
- Press out stop screw (3).
- Pull out piston with spring (4).
- Loosen spring from ring groove.
- Check piston and sealing rings (5) for damage.
- Install in the reverse order of removal.



Note:

Lightly coat sealing rings with brake fluid before installing.

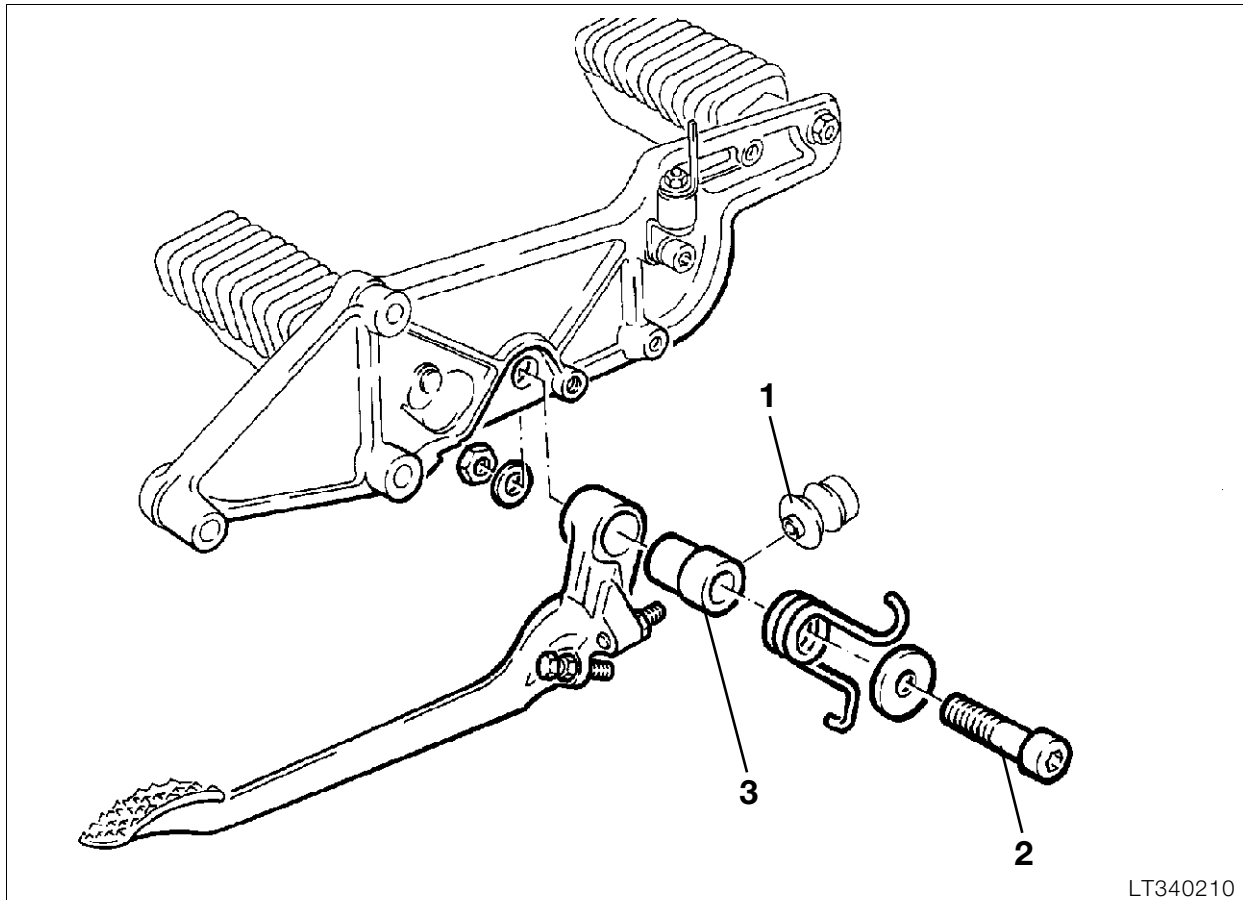

LT340210

Removing and installing brake pedal

- Remove footrest plate.
- Detach sealing gaiter (1) at master brake cylinder.
- Release mounting (2) for brake pedal.



Caution:
Spring is under tension.

- Remove bearing bush (3).
- Install in the reverse order of removal.



Note:
Grease bearing bush with „**Shell Retinax A**“ or similar.



Tightening torque:
Brake pedal..... 25 Nm

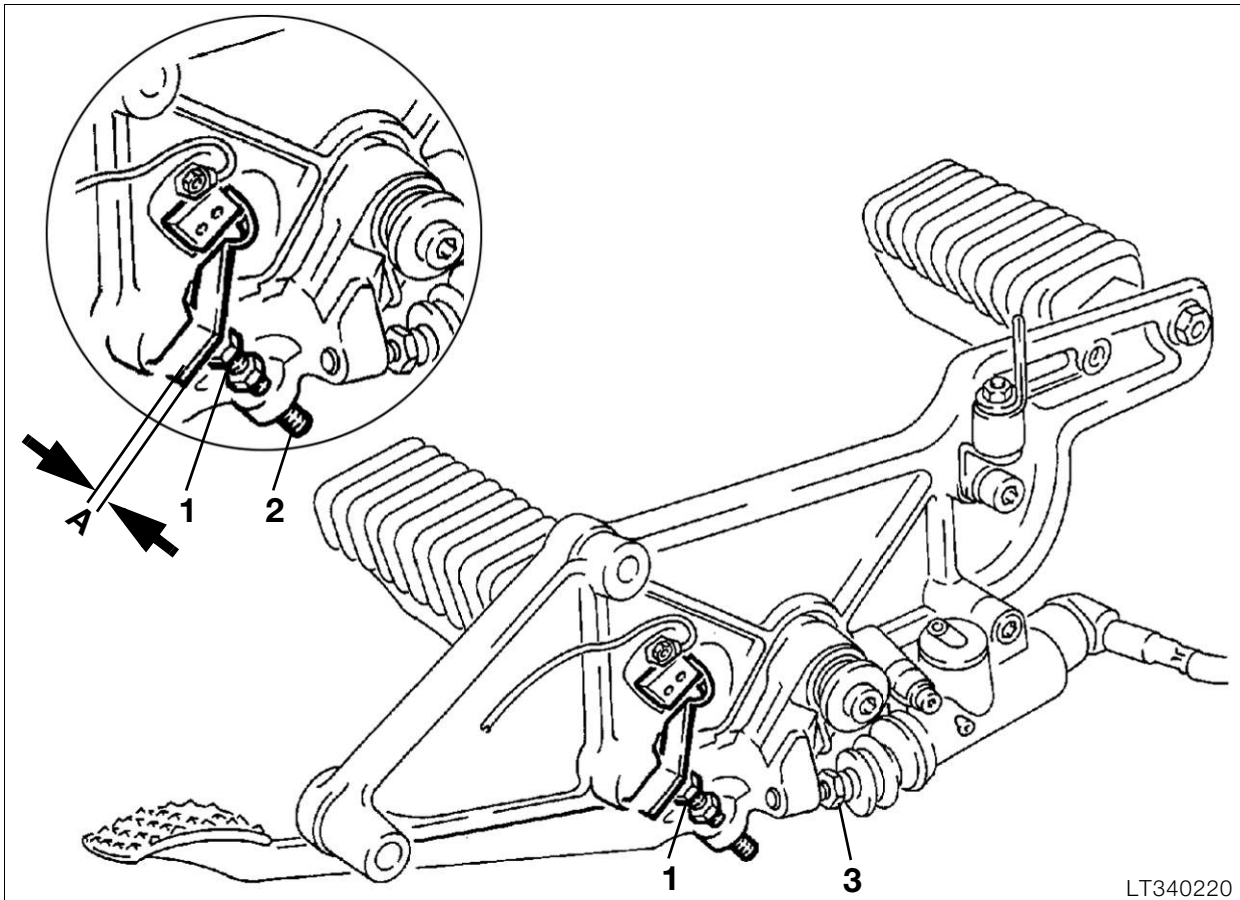

Adjusting foot brake pedal

- Loosen locknut (1).
- Perform basic setting with adjusting screw (2).
- Adjust distance „A“ with feeler gauge.

Basic setting:

Distance „A“ 0.2 mm (0.00787 in)

- Turn adjusting screw (3) on master brake cylinder until slight resistance is felt when the foot brake pedal is operated.
- Firmly tighten locknut, and remove feeler gauge.

Tightening torque:

Locknut,
adjusting screw on master brake cylinder 6 Nm

Troubleshooting: Front wheel/rear wheel brake

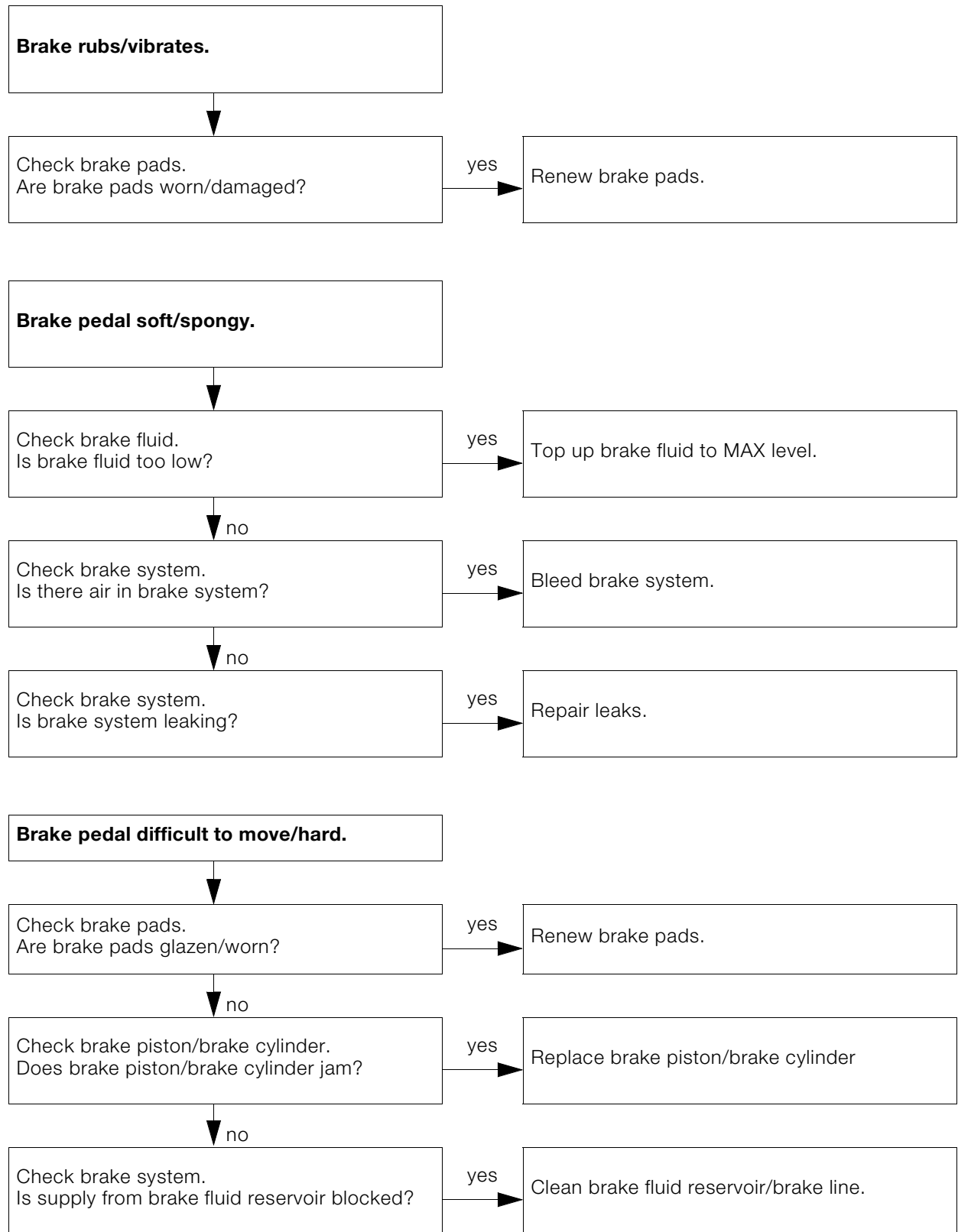

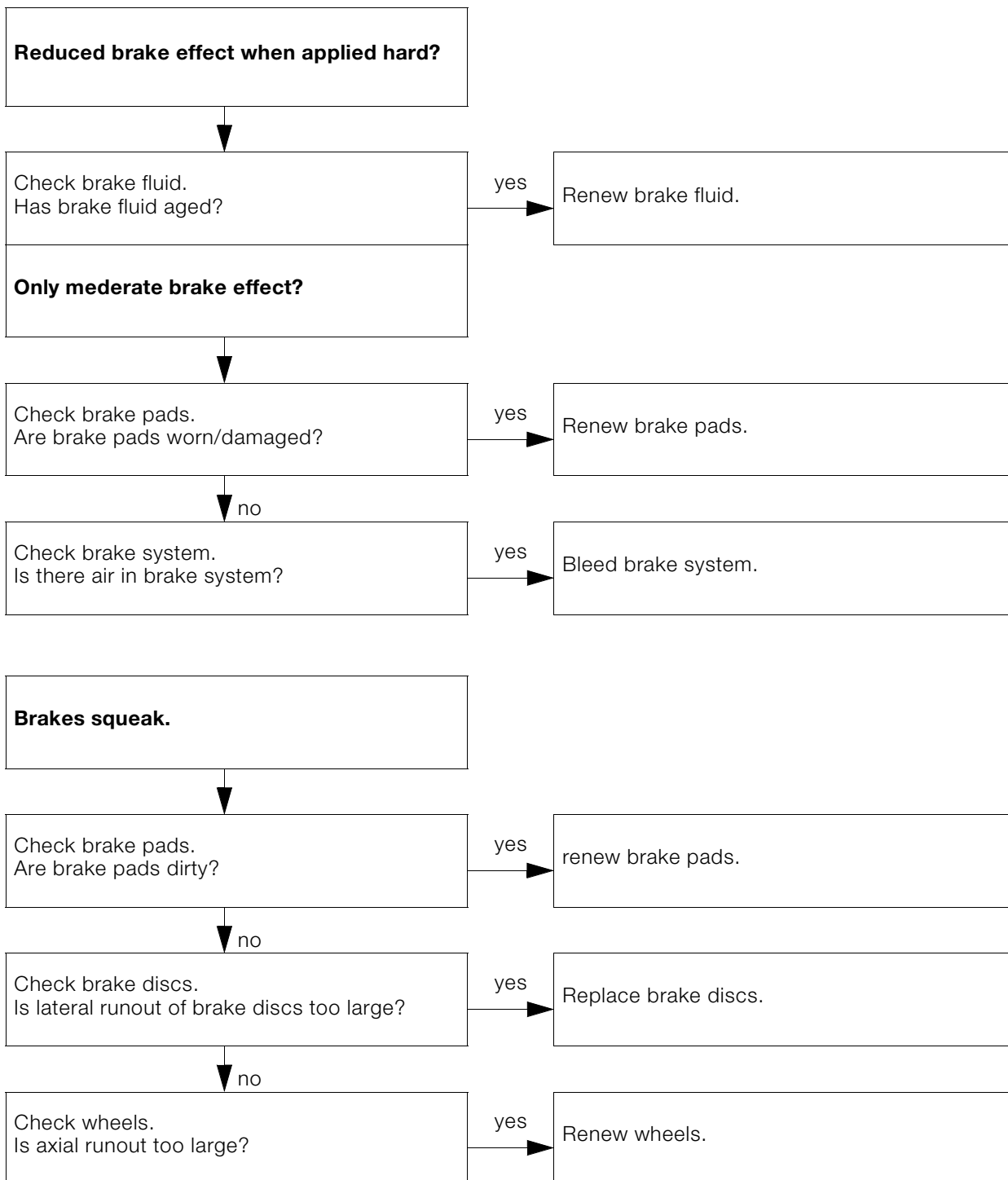
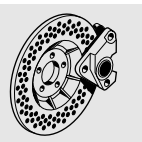

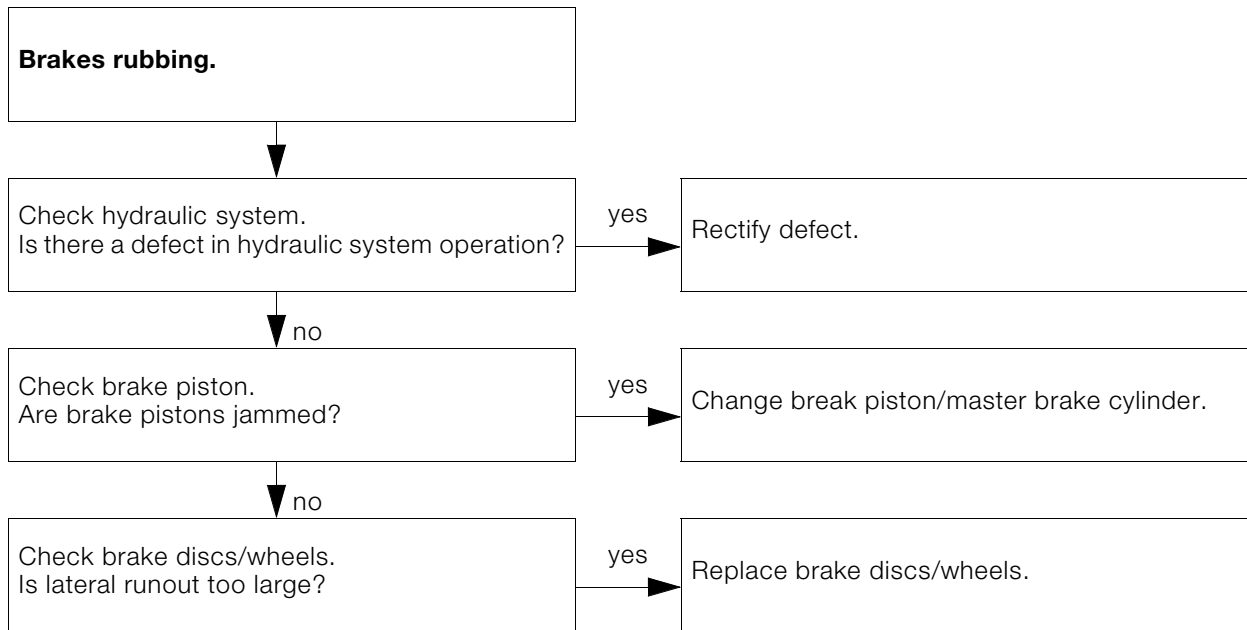

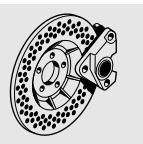

36 Wheels and tyres

Contents

Page

Technical Data	3
Removing and installing front wheel	5
Removing and installing wheel bearings	6
Removing left bearing	6
Removing right bearing	6
Installing left and right bearings	6
Removing and installing rear wheel	7
Removing rear wheel	7
Installing rear wheel	7
Static balancing of front and rear wheels	8
Static balancing of front wheel	8
Static balancing of rear wheel	8
Checking wheel for runout	9
Checking front wheel for runout	9
Checking rear wheel for runout	9



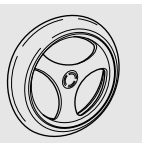

Technical Data			K 1100 LT	K 1100 RS
Rim size	front		2.50 x 18 MT H 2	3.50 x 17 MT H 2
	rear		3.00 x 17 MT H 2	4.50 x 18 MT H 2
Vertical runout		mm (in)	0.3 (0.012)	
Lateral runout		mm (in)	0.3 (0.012)	
Tyre size	front		110/80 VB 18 Tubeless	120/70 VB 17 Tubeless
	rear		140/80 VB 17 Tubeless	160/60 VB 18 Tubeless
Tyre pressures (cold)	Solo, front	bar (psi)	2.2 (31.3)	
	Solo, rear	bar (psi)	2.5 (35.6)	
	Two-up, front	bar (psi)	2.5 (35.6)	
	Two-up, rear	bar (psi)	2.9 (41.2)	
Wheel bearing lubrication			Brand-name anti-friction bearing grease, working temperature range -30...+140 °C, drip point 150...230 °C, high corrosion protection, good resistance to water and oxidation, e.g. Shell Retinax A	



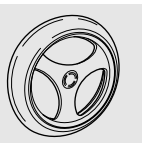

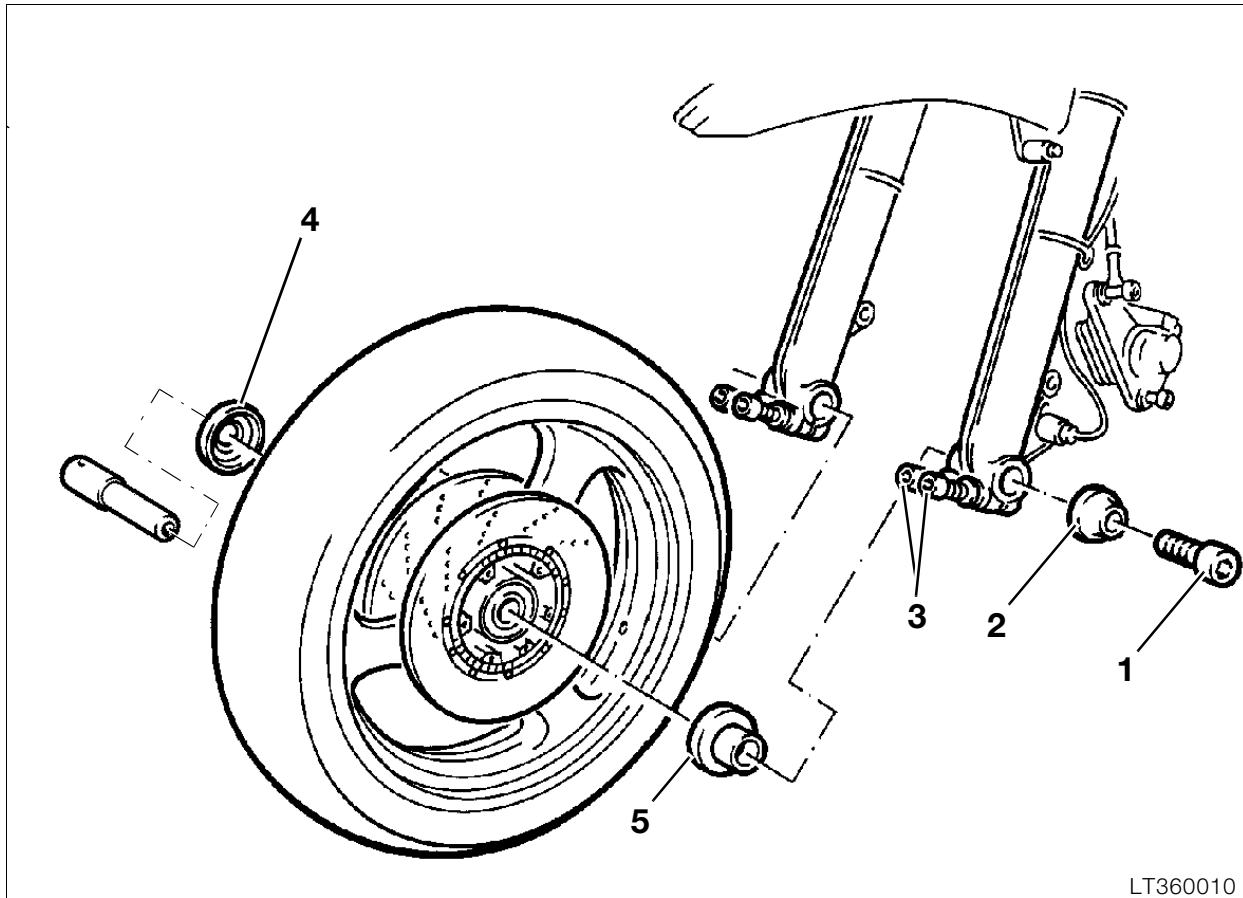

LT360010

Removing and installing front wheel

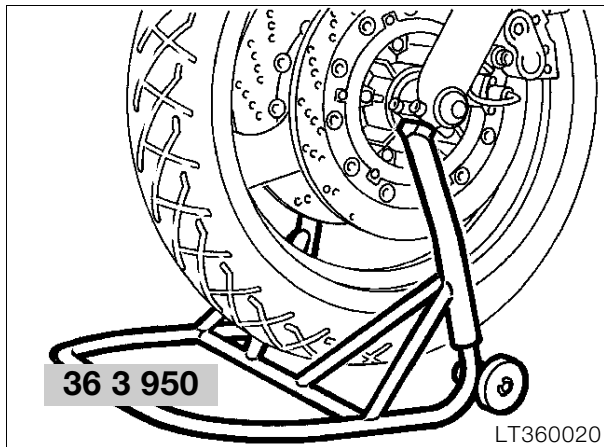

LT360020

- **[RS]** Raise the front wheel with the front wheel stand, **BMW No. 36 3 950**.
- **[LT]** Raise the front wheel with the front wheel stand and adapter, **BMW No. 36 3 954**.
- **[LT]** Remove the rear mudguard.
- Apply adhesive tape to the top of the brake caliper on the wheel side, to protect the wheel.
- Remove brake calipers on both sides and allow to hang down.
- Remove machine screw (1) and take out with taper washer (2).

- Loosen the left and right clamp screws (3) on the fork.
- Pull out the quick-release axle, noting the presence of spacers (4, 5).
- Remove front wheel.



Note:

Do not apply the brake when the front wheel is removed.

- Installation in the reverse order of work.
- Check **ABS** sensor gap and adjust if necessary.



Note:

Install the wider spacer (5) at the left. First tighten the quick-release axle, then the left clamp screws. Compress the fork several times, then tighten the right clamp screw.

Tightening torques:

Quick-release axle 33 Nm
 Quick-release axle clamp screws 14 Nm
 Brake caliper at fork slider tube 32 Nm

ABS sensor gap, front

Up to 1996
 model year 0.50...0.55 mm (0.020...0.022 in)
 From 1997
 model year on 0.45...0.55 mm (0.018...0.022 in)



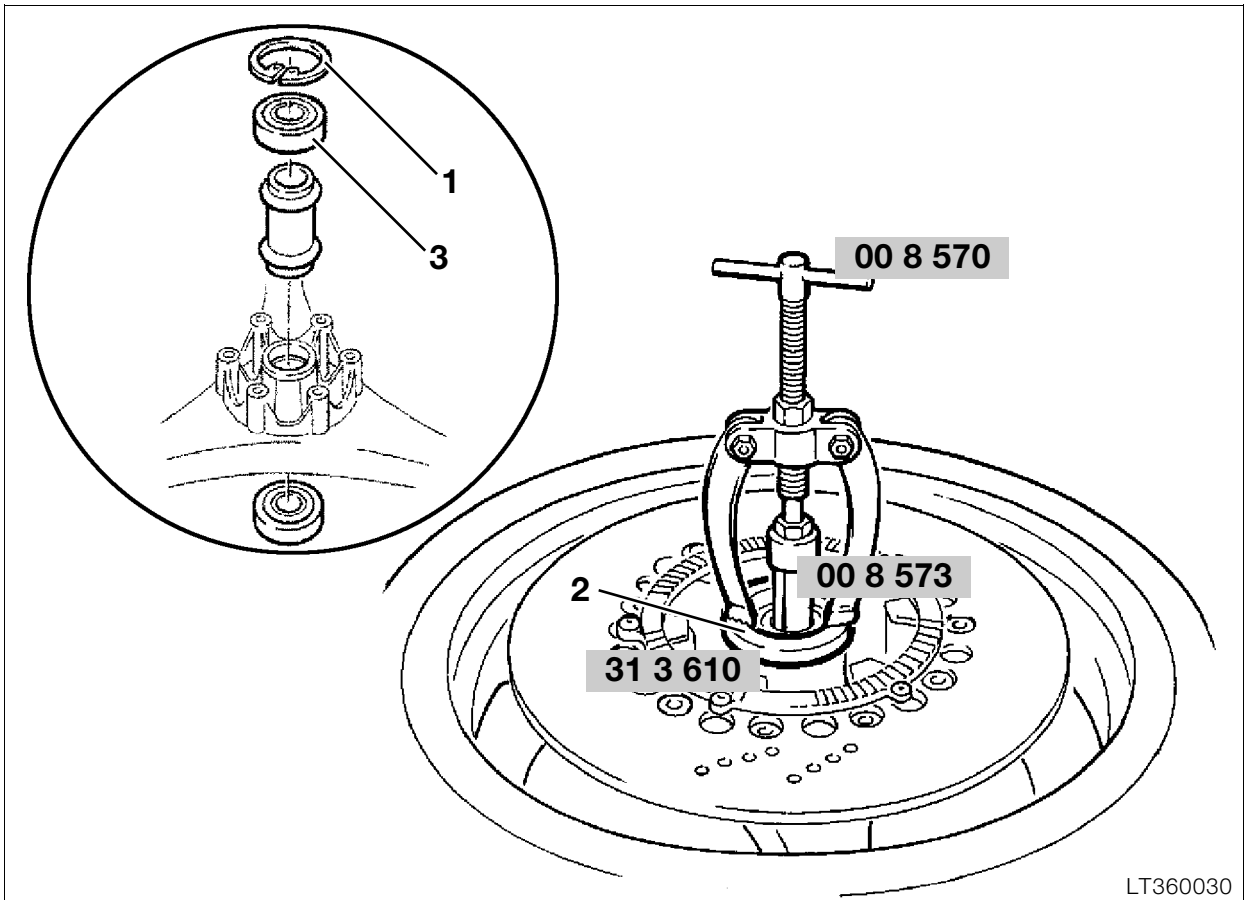

LT360030

Removing and installing wheel bearings

- Place the wheel on two wooden blocks so that the brake disc is free.

Removing left bearing

- Take out circlip (1) with Seeger circlip pliers.
- Place the protective ring (2), **BMW No. 31 3 610**, in position with the open side upwards.
- Pull out wheel bearing (3) with internal puller, **BMW No. 00 8 570**, and insert, **BMW No. 00 8 573**.

Removing right bearing

- The right bearing has no circlip.
- Place the protective ring in position with the open side against the wheel hub.
- Pull the bearing out in the same way as for the left bearing.

Installing left and right bearings

- Heat the bearing seat to 100 °C.
- Apply a thin coat of **Loctite 638** to the outer bearing race.
- Drive the bearing in with a drift, **BMW No. 36 3 660/670**.
- Install the circlip at the left bearing.

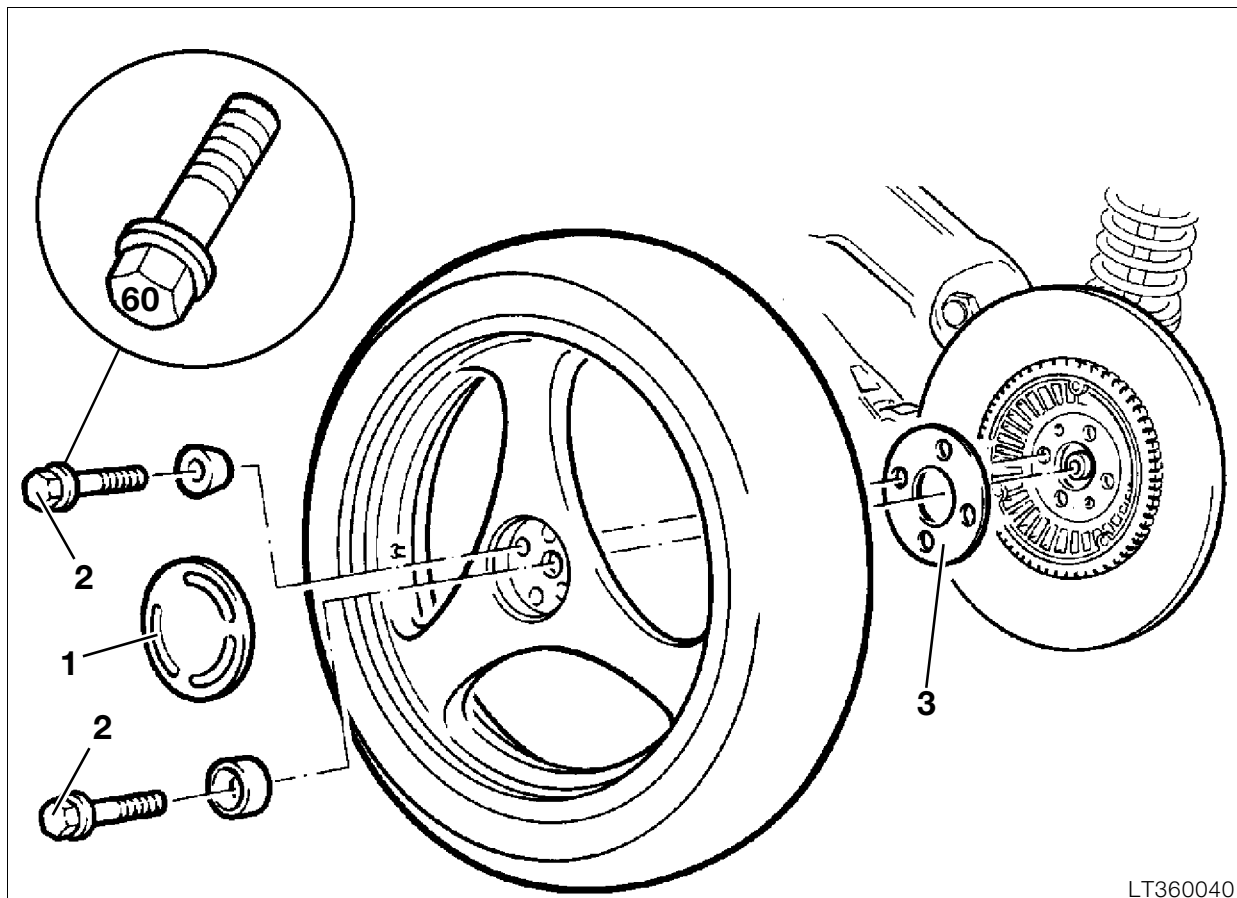

LT360040

Removing and installing rear wheel

Removing rear wheel

- Remove number plate bracket.
- Remove the brake caliper.
- Pull off cap (1) with an angled screwdriver.
- Unscrew wheel studs (2).
- Take out the rear wheel.
- Note the presence of spacing washer (3).

Installing rear wheel

- The contact faces on the spacing washer, the rear wheel drive and the wheel hub must be free from grease and clean.
- Offer the rear wheel with the spacing washer up to the rear wheel drive, and screw in all wheel studs handtight.



Caution:

Only use wheel studs with length code 60.

- Tighten the outer wheel studs in a crosswise pattern to the preload torque.
- Tighten the central stud to the specified torque.
- Tighten the outer wheel studs in a crosswise pattern to the specified torque.
- Install brake caliper.

Tightening torque:

Preload torque	50 Nm
Wheel studs/central stud	105 Nm
Brake caliper to rear wheel drive	32 Nm

- Check **ABS** sensor gap.

ABS sensor gap, rear

Up to 1996	
model year	0.60...0.65 mm (0.024...0.026 in)
From 1997	
model year on	0.45...0.55 mm (0.018...0.022 in)

- Install number plate holder.

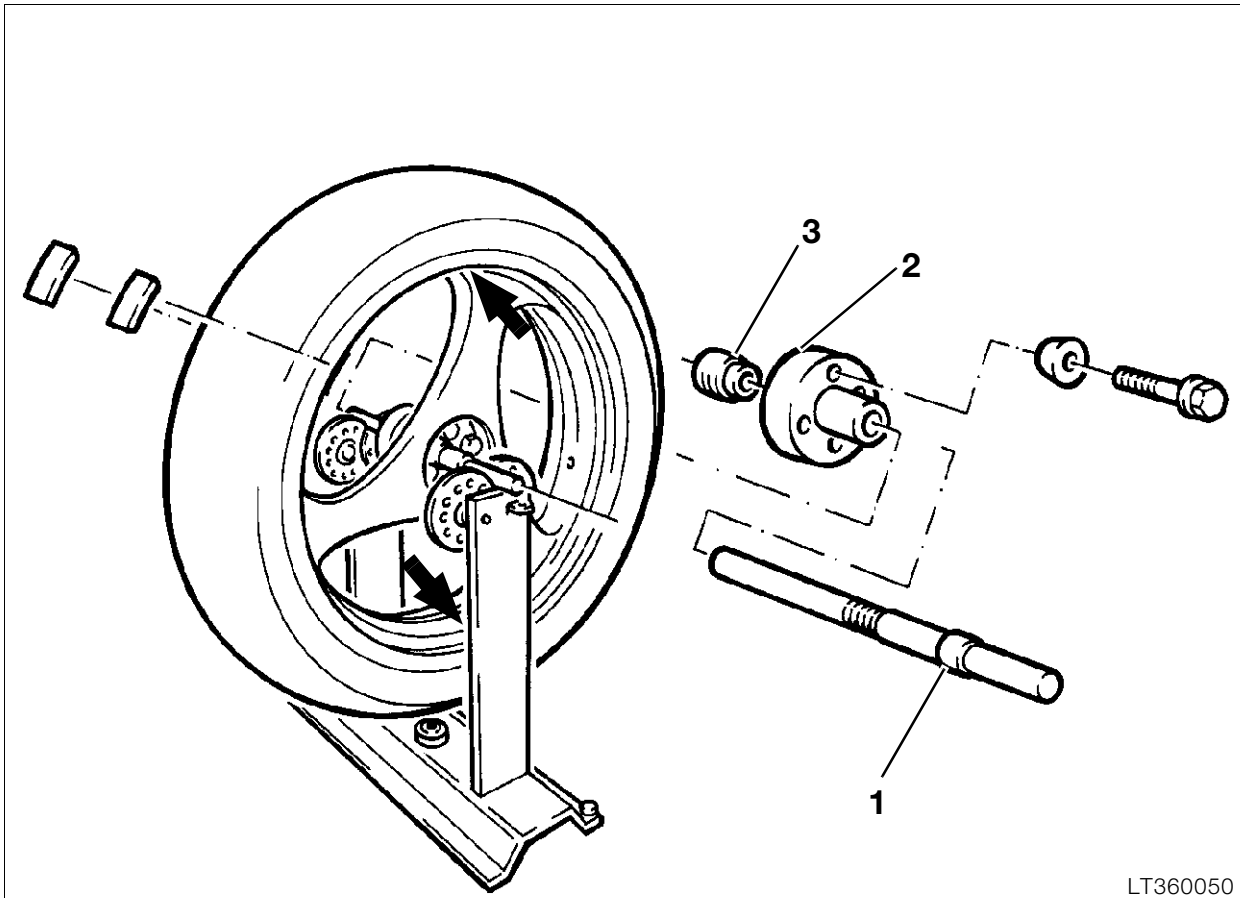

LT360050

Static balancing of front and rear wheels

Static balancing of front wheel

- Remove the wheel.
- Insert the balancing shaft, **BMW No. 36 3 614**, through the front wheel.
- Secure the balancing axle with knurled nut (3), but do not over-tighten.
- Raise the wheel on the balancing device, **BMW No. 36 3 600**, and allow it to find its own equilibrium.



Note:

Attach weights (distributed evenly between the two sides of the wheel) opposite the heaviest point at either side of the rim. Maximum total balance weight 60 g.

- If necessary, repeat the balancing procedure.
- Check **ABS** sensor gap.

ABS sensor gap, front

Up to 1996

model year 0.50...0.55 mm (0.020...0.022 in)

From 1997

model year on 0.45...0.55 mm (0.018...0.022 in)

Static balancing of rear wheel

- Remove the wheel.
- Attach mounting device (2), **BMW No. 36 3 613**, to the centering-collar side with the wheel studs.
- Install balancing shaft (1), **BMW No. 36 3 606**, with measuring socket (3), **BMW No. 36 3 616**.



Note:

Equalise the position of the wheel on the balancing shaft with spacing washers, e.g. Part No. 36 31 1 451 791.

- Raise the wheel on the balancing device, **BMW No. 36 3 600**, and allow it to find its own equilibrium.



Note:

Attach weights (divided evenly between both sides of the wheel) opposite the heaviest point at both sides of the rim. Maximum balancing weight is 60 g.

- If necessary, repeat the balancing procedure.
- Check **ABS** sensor gap.

ABS sensor gap, rear

Up to 1996

model year 0.60...0.65 mm (0.024...0.026 in)

From 1997

model year on 0.45...0.55 mm (0.018...0.022 in)

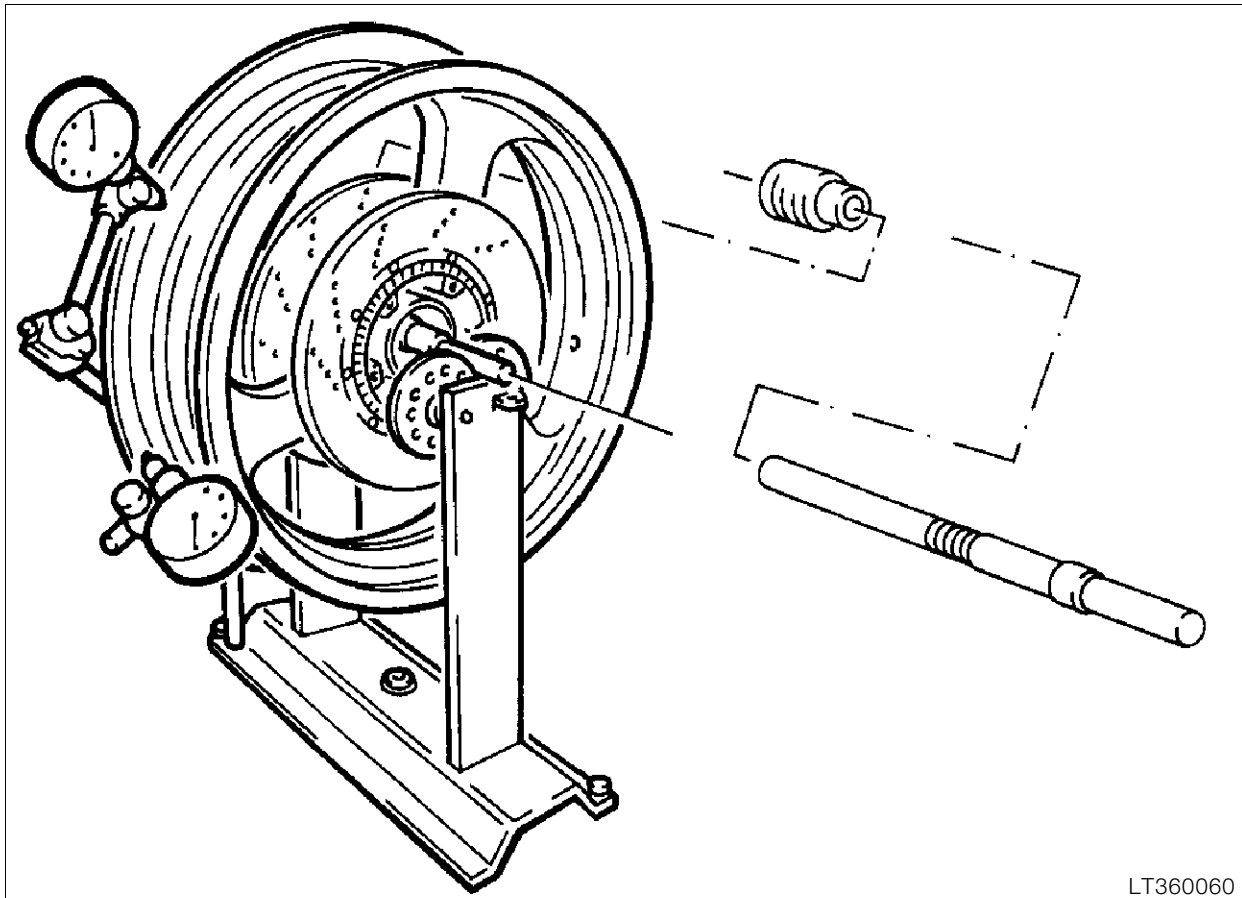

LT360060

Checking wheel for runout

Checking front wheel for runout

- Install the wheel without tyre on the balancing shaft, **BMW No. 36 3 614**, and balancing stand, **BMW No. 36 3 600**.
- When checking the front wheel, use a pin in the balancing shaft to prevent it from turning in the balancing stand.
- To check the rear wheel, clamp retaining discs, **BMW No. 36 3 615**, at left and right on the balancing shaft so that the shaft cannot wander to and fro.



Note:

Only apply dial gauge to machined inner face of wheel rim.

Maximum wheel rim runout:

Vertical runout..... 0.3 mm (0.012 in)
Lateral runout..... 0.3 mm (0.012 in)

Checking rear wheel for runout

- Attach the rear wheel without tyre to mounting device (2), **BMW No. 36 3 613**, and secure on the centering collar side with wheel studs.
- Install balancing shaft (1), **BMW No. 36 3 606**, with measuring socket (3), **BMW No. 36 3 616**.



Note:

Centre the wheel on the balancing shaft with spacing washers, e.g. Part No. 36 31 1 451 791.

- Mount the wheel on balancing stand, **BMW No. 36 3 600**.
- To check the rear wheel, clamp locating discs, **BMW No. 36 3 615**, on the balancing shaft at left and right so that the shaft cannot wander to and fro.



Note:

Only apply dial gauge to machined inner face of wheel rim.

Maximum wheel rim runout:

Vertical runout..... 0.3 mm (0.012 in)
Lateral runout..... 0.3 mm (0.012 in)

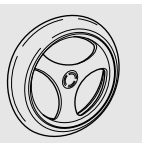

46 Frame

Contents

Page

Technical Data	3
Removing and installing front mudguard	5
Removing and installing rear section	6
Removing and installing rear mudguard	7
Removing and installing fairing [LT]	8
Removing side sections of fairing	8
Removing radiator cowling	8
Removing and installing windshield	9
Removing and installing windshield complete with motor	9
Disassembling and assembling adjustable windshield	10
Removing and installing actuator motor	10
Removing plate	10
Removing lever	11
Removing guide bush in lever	11
Removing sliding piece	11
Removing and installing upper section of fairing	12
Removing and installing fairing [RS]	13
Removing and installing lower section of fairing	13
Removing and installing side section of fairing	13
Removing and installing radiator cowling	13
Removing and installing upper section of fairing	14
Removing and installing windshield, spoiler and headlamp	14
Removing and installing fairing support bracket	15
Arrangement of cable clips [LT]	15
Arrangement of cable clips [RS]	15
Checking running gear	16
Measuring track offset	16



Checking frame with gauge	18
Removing and installing frame	20
Removing frame	20
Disassembling and assembling frame	20
Removing outer bearing race in steering head	20
Installing outer bearing race in steering head	20
Removing and installing seat lock	21
Removing and installing handle	21
Installing frame	22
Removing and installing main centre stand	23
Line arrangement for side stand	23
Disassembling and assembling side stand	24
Disassembling side stand	24
Assembling side stand	25
Disassembling and assembling main centre stand	26
Checking switching function of side stand	27



Technical Data		K 1100 LT	K 1100 RS
Location of type identification plate		Rear right frame tube	
Location of chassis number		Rear right frame tube	
Maximum width (over mirrors)	mm (in)	915 (36.02)	802 (31.57)
Seat height, without load	mm (in)	810 (31.89)	800 (31.5)
Wheelbase, without load	mm (in)	1565 (61.6)	
Unladen weight	kg (lb)	290 (639.45)	268 (590.9)
Gross weight	kg (lb)	480 (1058.4)	
Track offset	mm (in)	12 (0.47)	
Steering head angle	°	27	





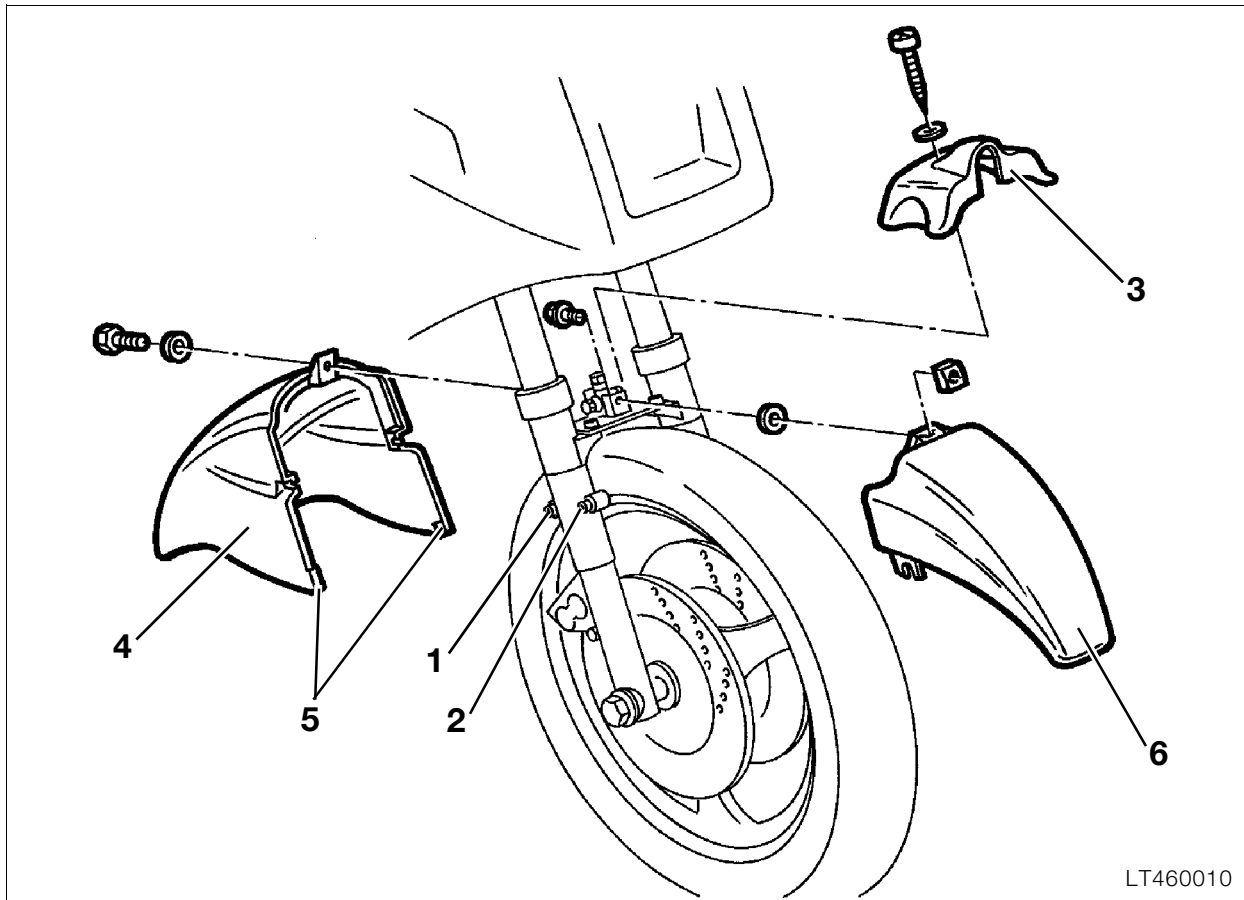

LT460010

Removing and installing front mudguard

- Loosen clamping screws (1,2).
- Detach cover (3).
- Remove rear section of mudguard (4).
- **[LT]** Detach Velcro connections (5).
- Remove front section of mudguard (6).
- Install in the reverse order of removal.

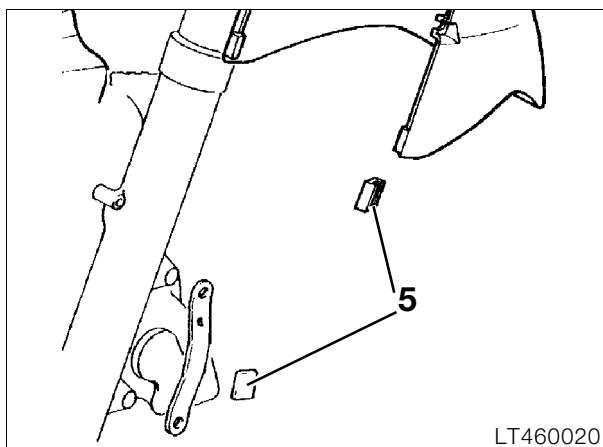

LT460020



Note:
[LT] Position of Velcro connection (6).

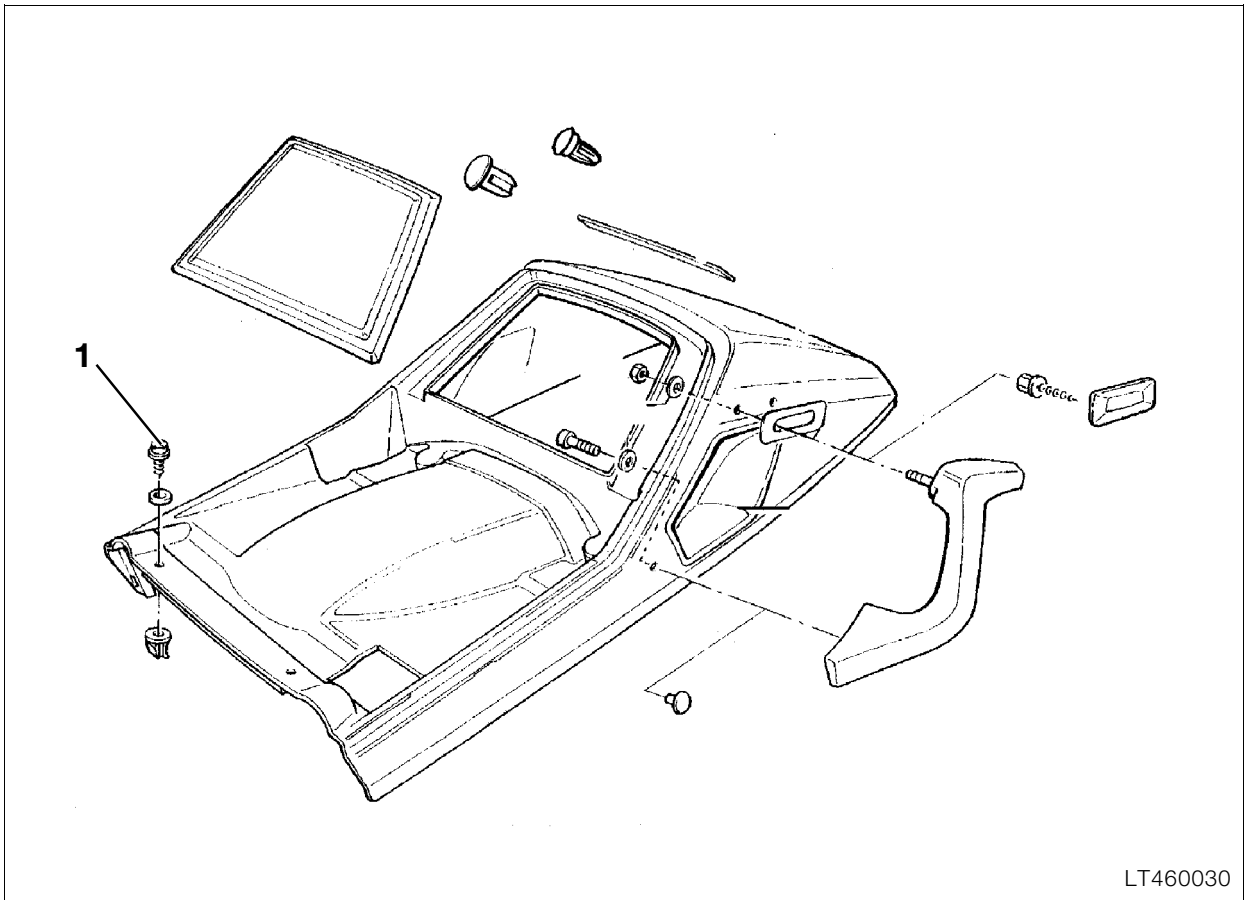

LT460030

Removing and installing rear section

- Remove dualseat.
- Remove combined tail light unit.
- Release securing screw (1).
- Install in the reverse order of removal.

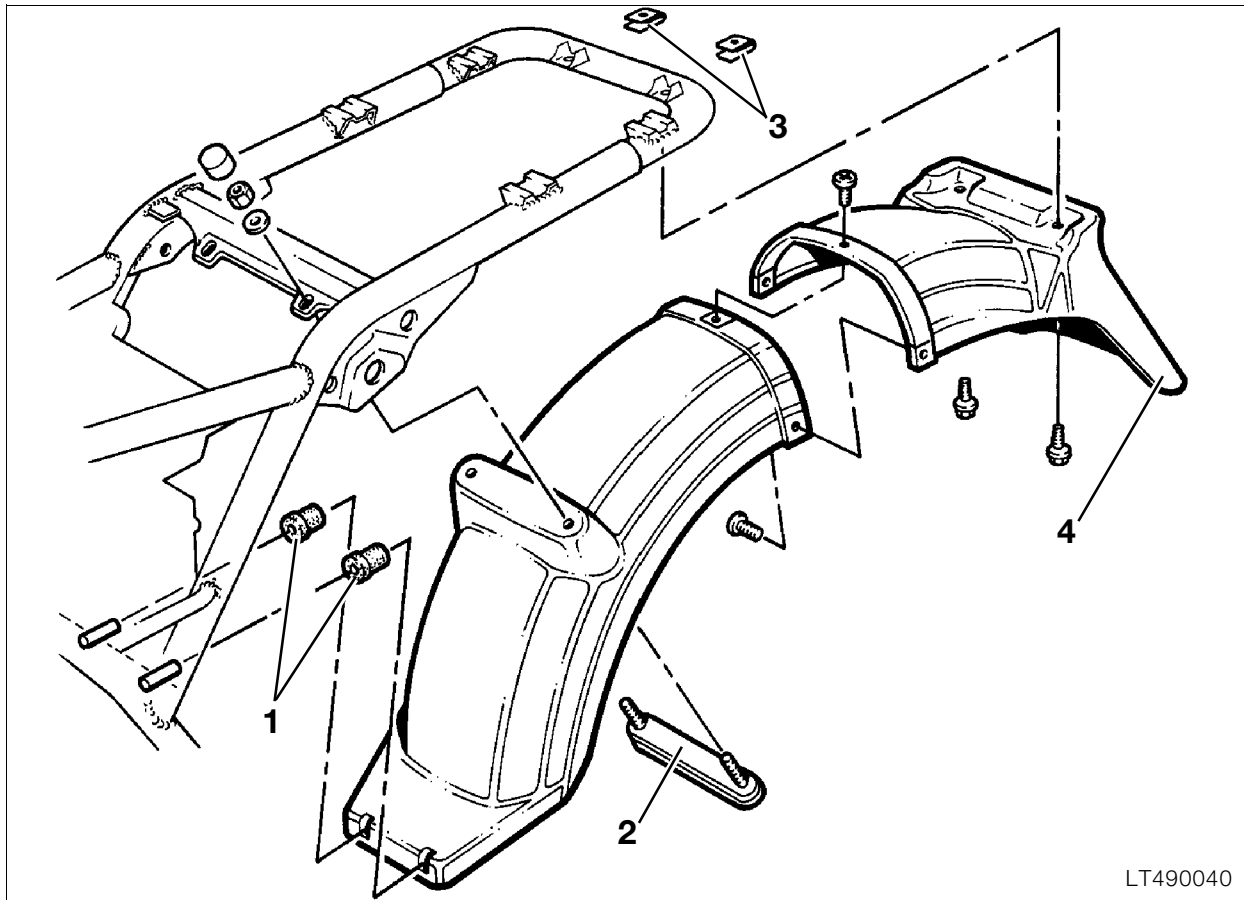

Removing and installing rear mudguard

1. Rubber sleeves on gearbox
2. Bracket
3. Sheet-metal nuts
4. Licence plate support bracket



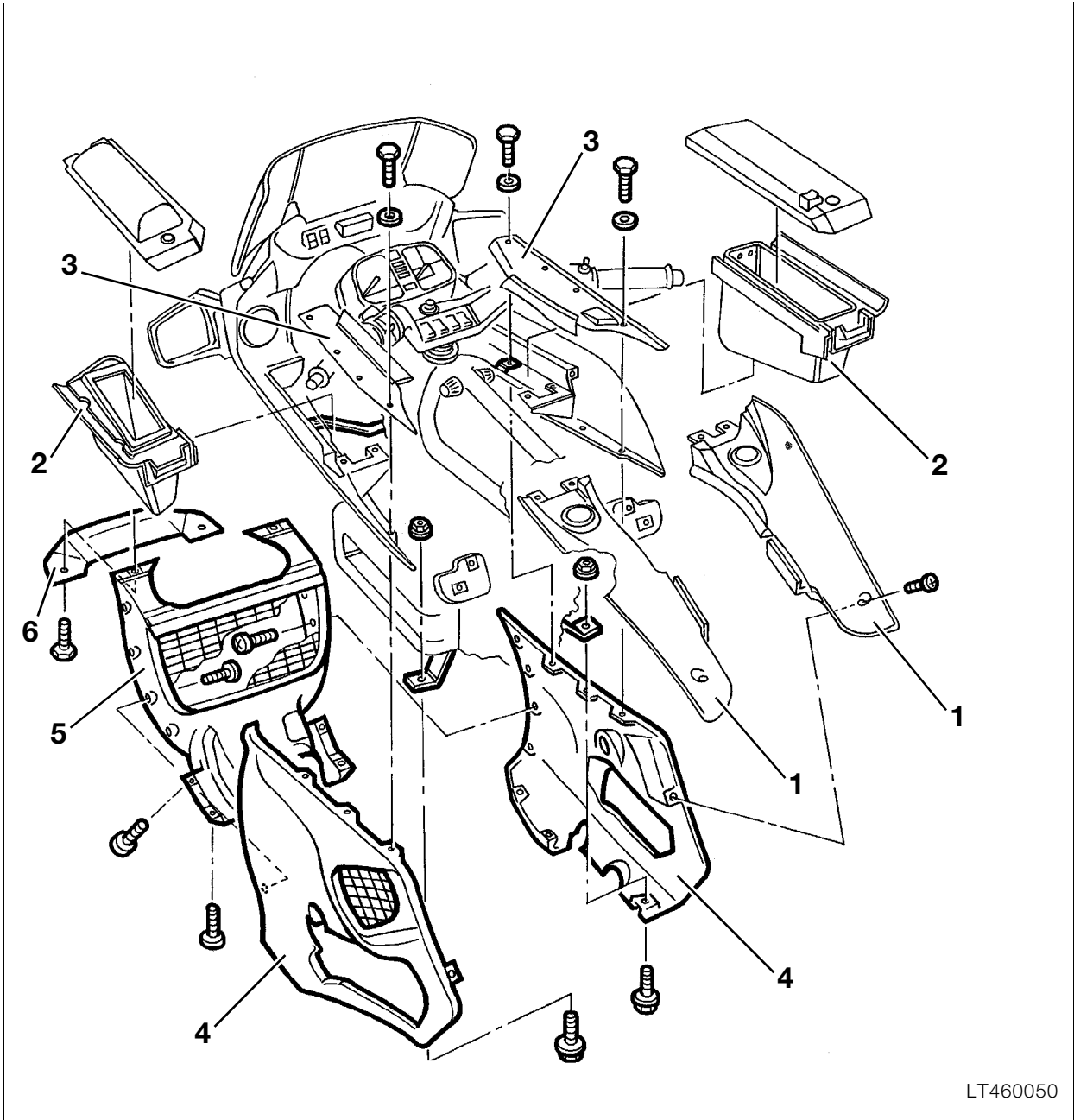

LT460050

Removing and installing fairing [LT]

Removing side sections of fairing

- Remove knee pad (1).
- Remove storage box (2).
- Remove cover (3).
- Remove side section (4).
- Install in the reverse order of removal.

Removing radiator cowling

- Remove radiator cowling (5).
- Remove cover (6).

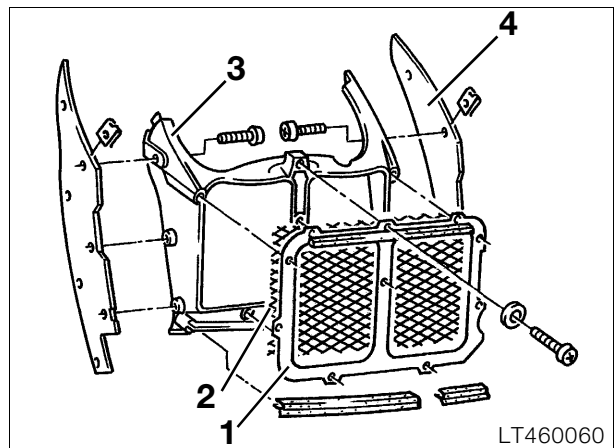

LT460060

1. Frame
2. Grille
3. Cowling
4. Cover

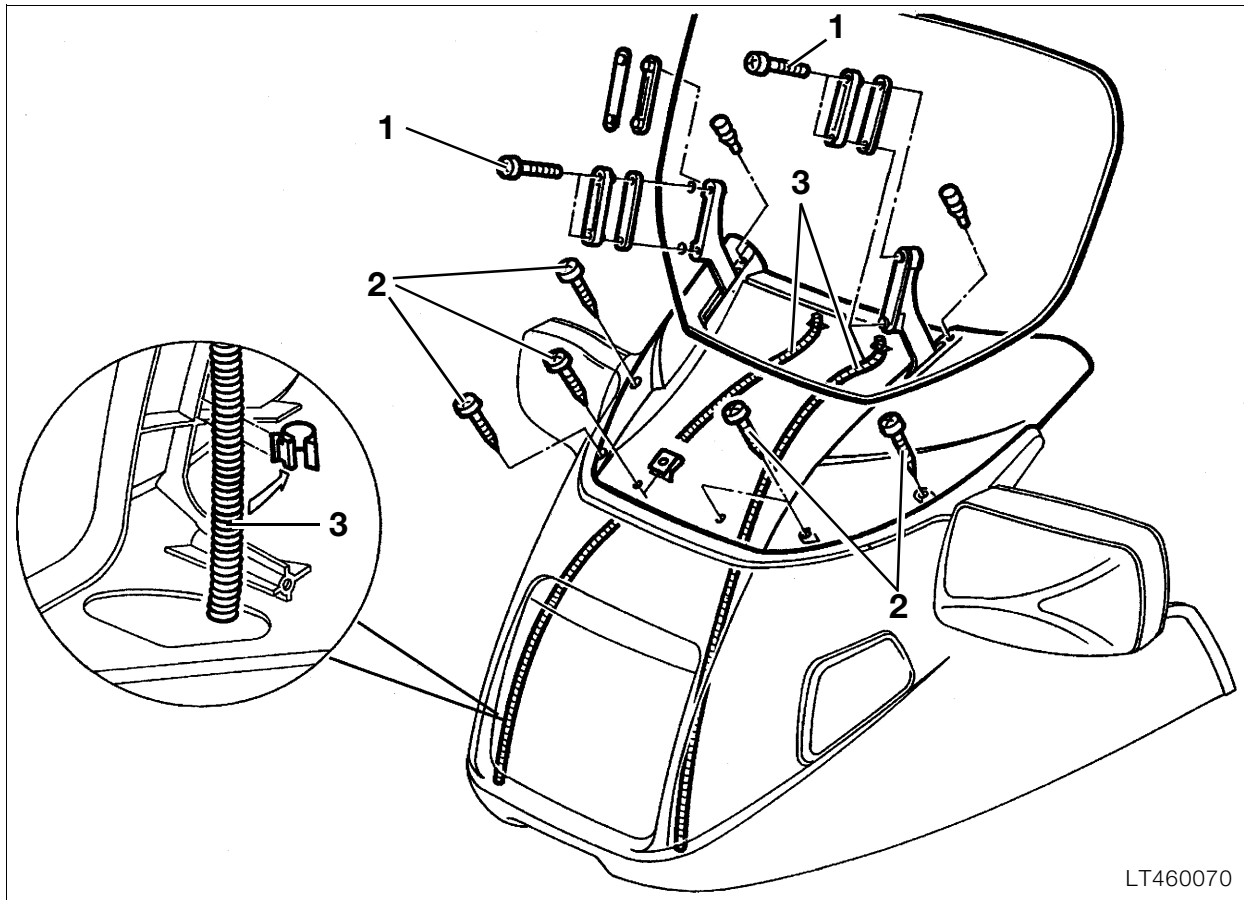

Removing and installing windshield

- Release securing screws (1) on left and right and detach screen.

Removing and installing windshield complete with motor

- Remove inner cover.
- Release securing screws (2).
- Detach water ducts (3) at the top nipple.
- Disconnect electrical plug connection.
- Remove windshield with motor.
- Install in the reverse order of removal.



Note:

Ensure the water ducts are fitted in the correct position.



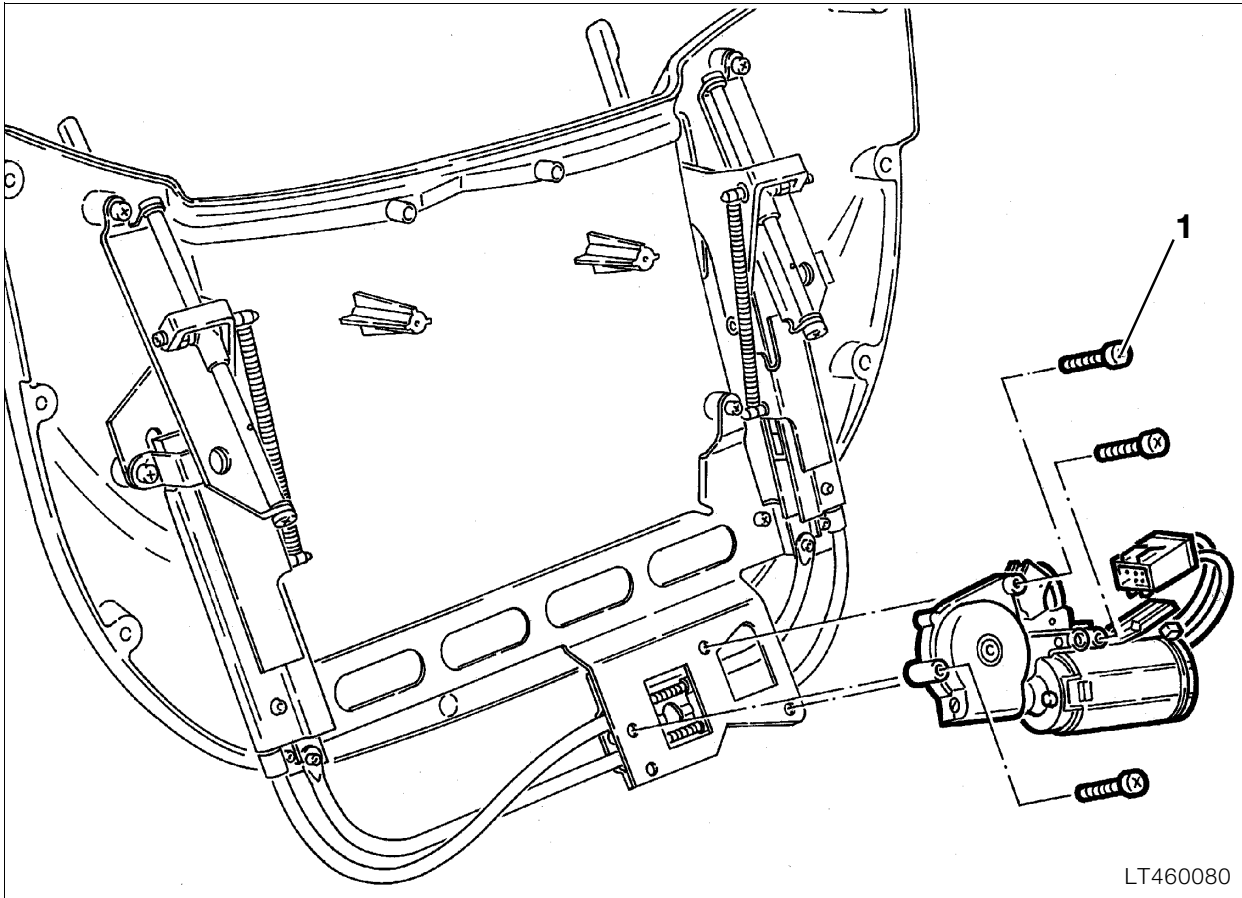

Disassembling and assembling adjustable windshield

Removing and installing actuator motor

- Release securing elements (1) for actuator motor and remove motor.

Removing plate

- Remove actuator motor

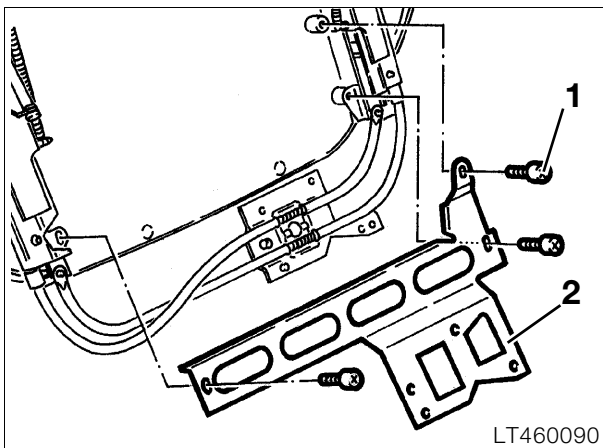

- Release mounting element (1) for plate (2).
- Install in the reverse order of removal.



Note:

The retaining screws are micro-encapsulated and therefore cannot be re-used. Clean the threads and the holes. Coat screws with **Loctite 243** before inserting.

Removing lever

- Remove actuator motor.
- Remove plate.
- Detach spring.

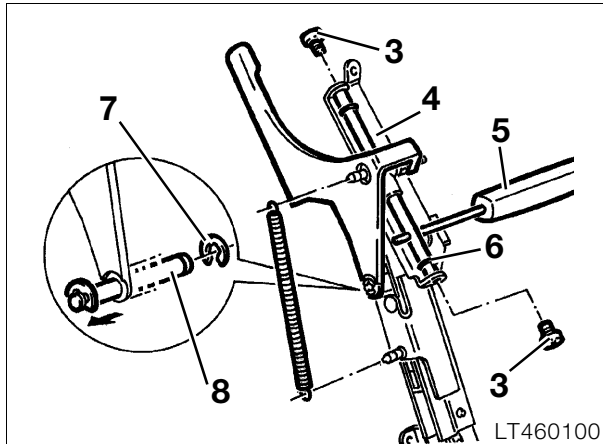

- Release securing element (3) of guide rod (4), while holding with pin (5).
- Pull guide rod out of sliding bushing, note O-rings (6).
- Remove retainer (7) and press out shaft (8).
- Install in the reverse order of removal.



Note:

The retaining screws are micro-encapsulated and therefore cannot be re-used. Clean the threads and the holes. Coat screws with Loctite 243 before inserting.
Spray guide rod with silicone spray.

Removing guide bush in lever

- Remove lever.

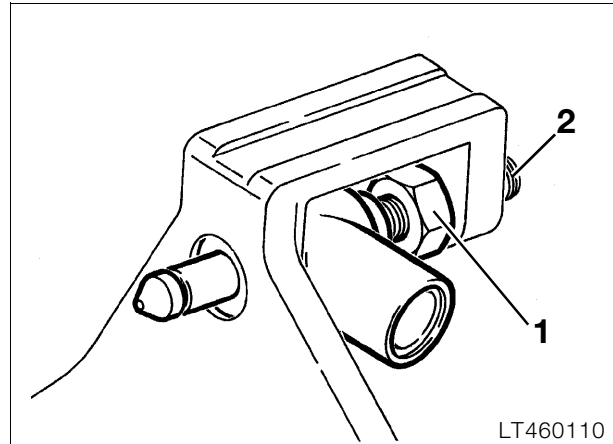

- Loosen locknut (1), unscrew pressure screw (2).



Note:

Installation:

Only tighten pressure screw such that the guide bush can still be moved easily, then lock with hexagon nut.



Tightening torque:

Locknut 7 Nm

Removing sliding piece

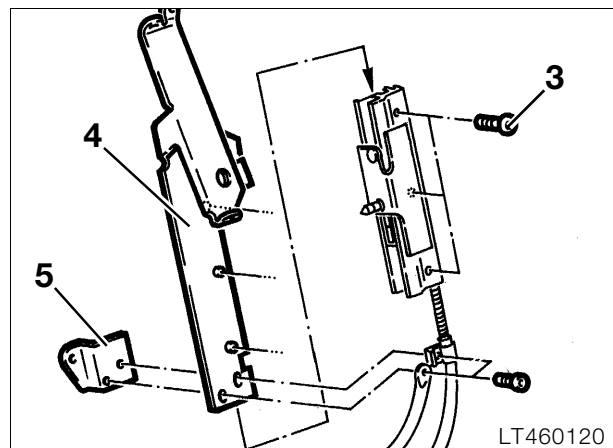

- Remove actuator motor.
- Remove plate.
- Remove lever.
- Release securing element (3) for sliding piece (4) on the plate.
- Remove retaining bracket (5) for tubes.
- Remove sliding piece completely out of tube.



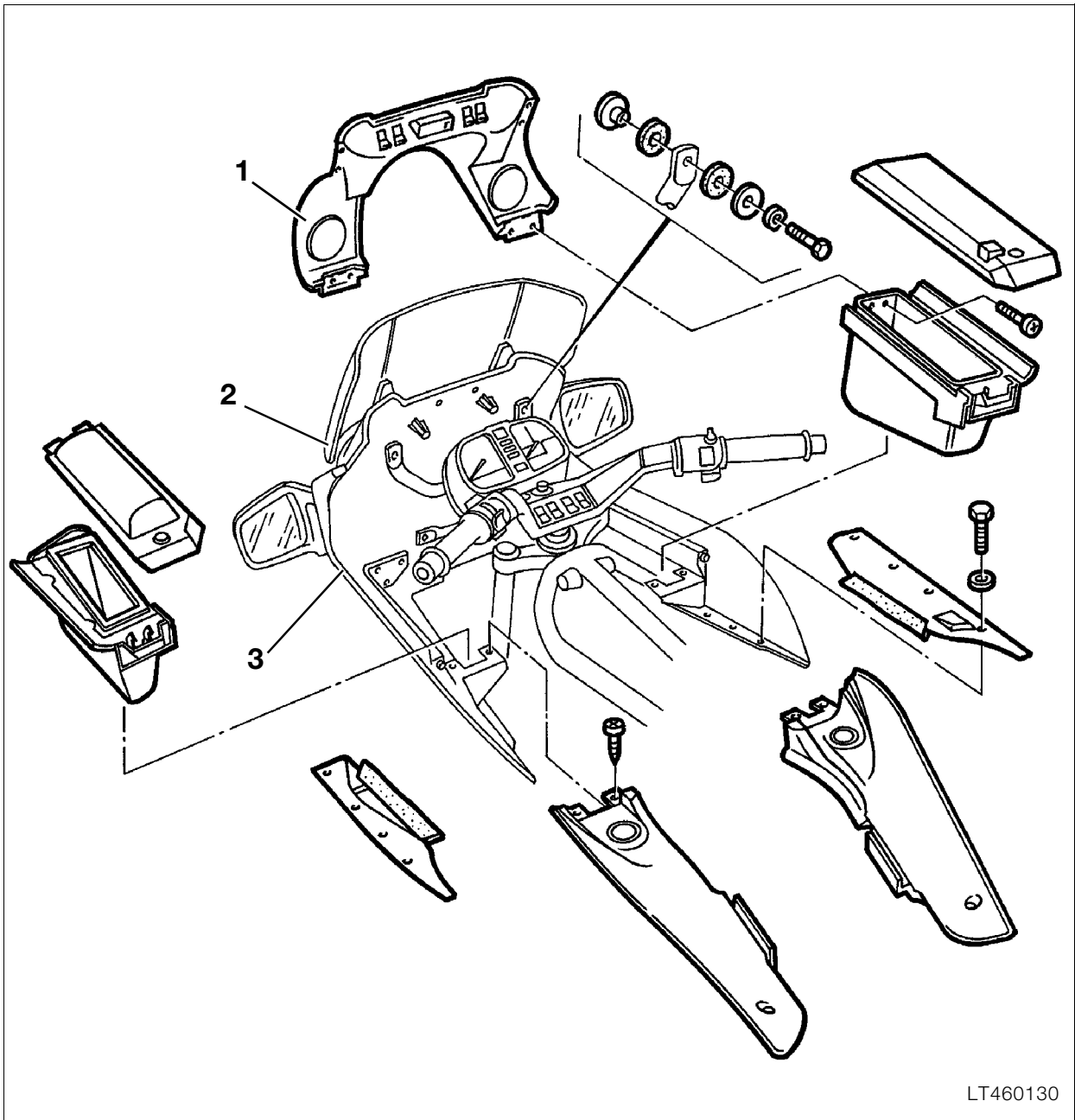

LT460130

Removing and installing upper section of fairing

- Remove side sections of fairing and radiator cowling.
- Remove cover (1).
- Remove complete windshield (2).
- Disconnect plug connections for headlight and turn indicators.
- Remove upper section of fairing (3).
- Install in the reverse order of removal.

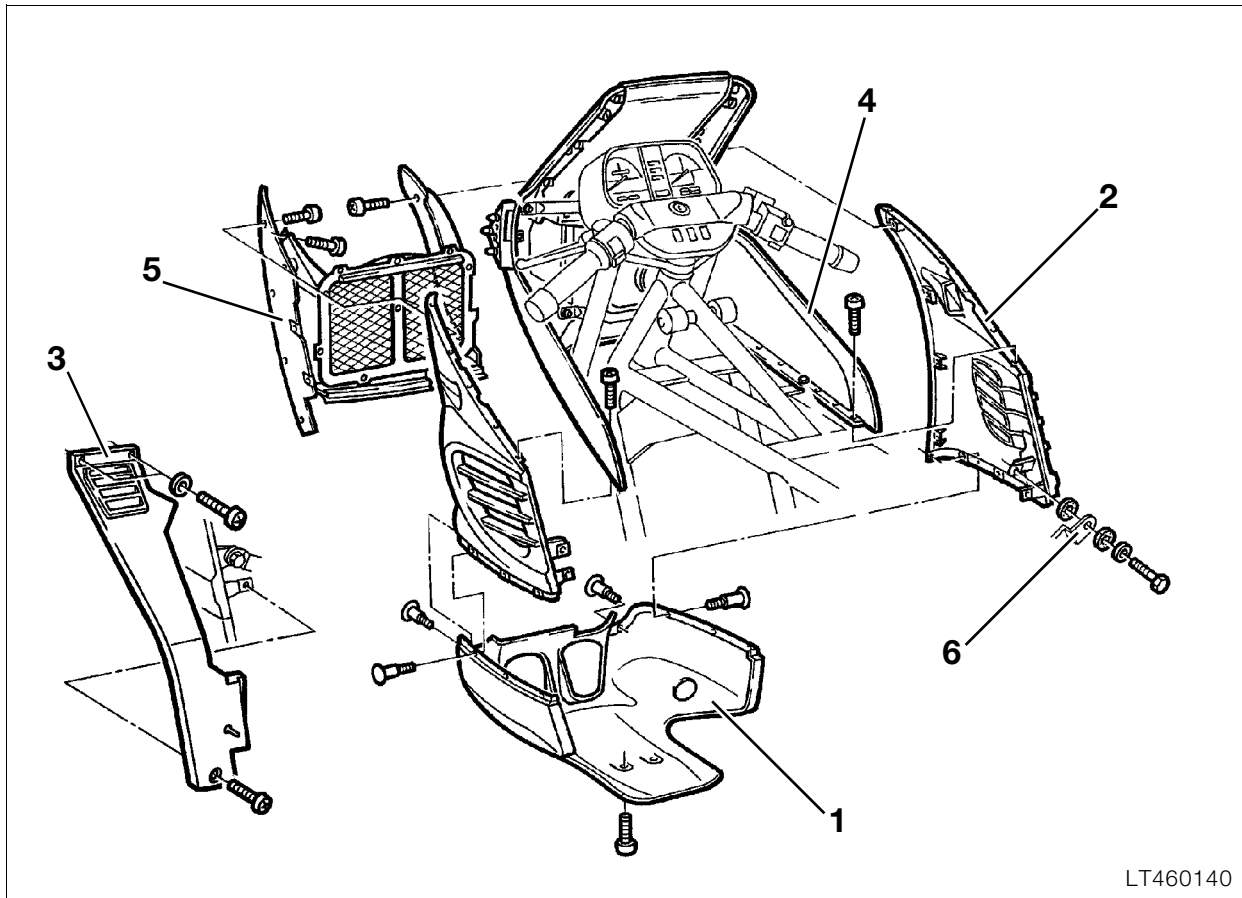

LT460140

Removing and installing fairing [RS]

Removing and installing lower section of fairing

- Lower section of fairing (1)
- Release securing element on side section (2).
- Release securing screw at oil sump.
- Install in the reverse order of removal.

Removing and installing side section of fairing

- Side section of fairing (2)
- Remove lower section of fairing (1).
- Remove knee pad (3).
- Release securing screw on upper section (4), on radiator cowling (5) and on bracket (6).
- Install in the reverse order of removal.

Removing and installing radiator cowling

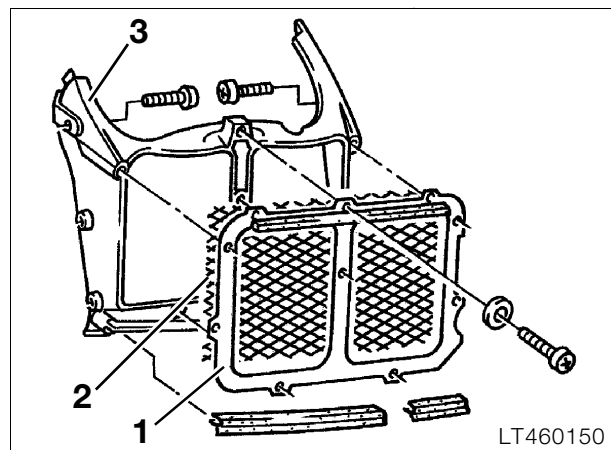

LT460150

- Radiator cowling (5)
- 1. Frame
- 2. Grille
- 3. Cowling

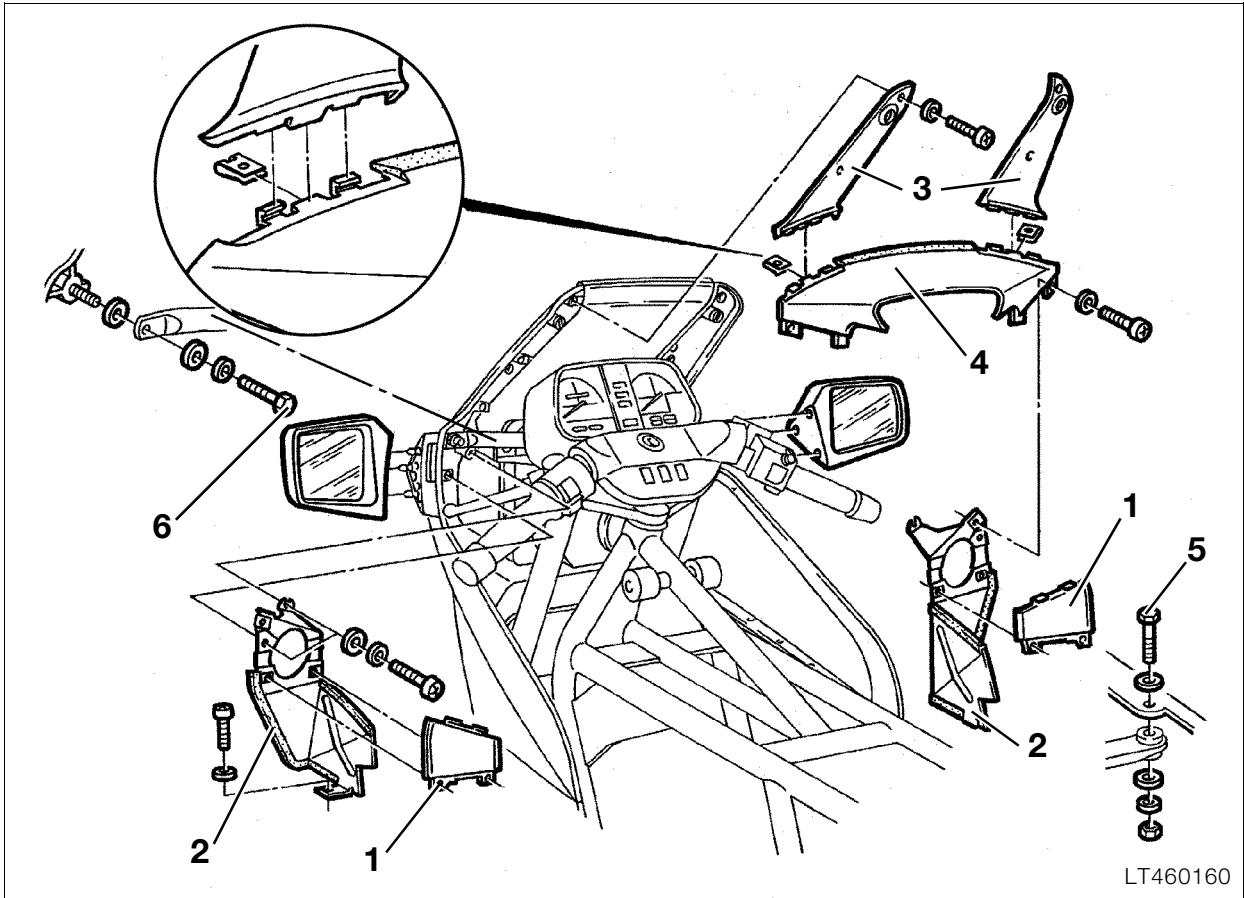

LT460160

Removing and installing upper section of fairing

- Remove lower section of fairing, side sections and radiator cowling.
- Remove cover (1).
- Remove support bracket (2).
- Remove cover at right/left (3) and centre (4).
- Disconnect plug connection for turn signal indicator and headlamp.
- Release securing screw (5) on frame and (6) at fairing support bracket.
- Remove fairing by pulling forward.
- Install in the reverse order of removal.

Removing and installing windshield, spoiler and headlamp

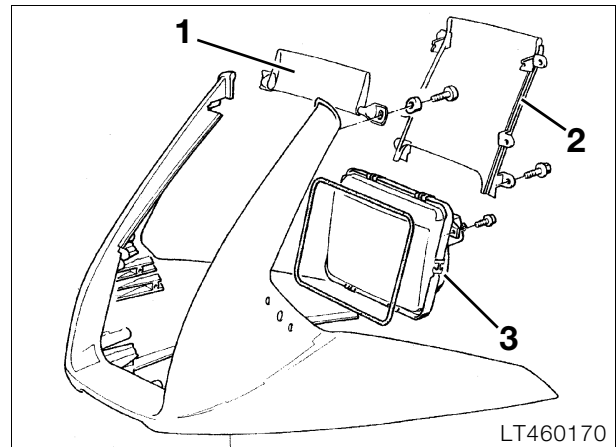

LT460170

1. Spoiler
2. Windshield
3. Headlamp

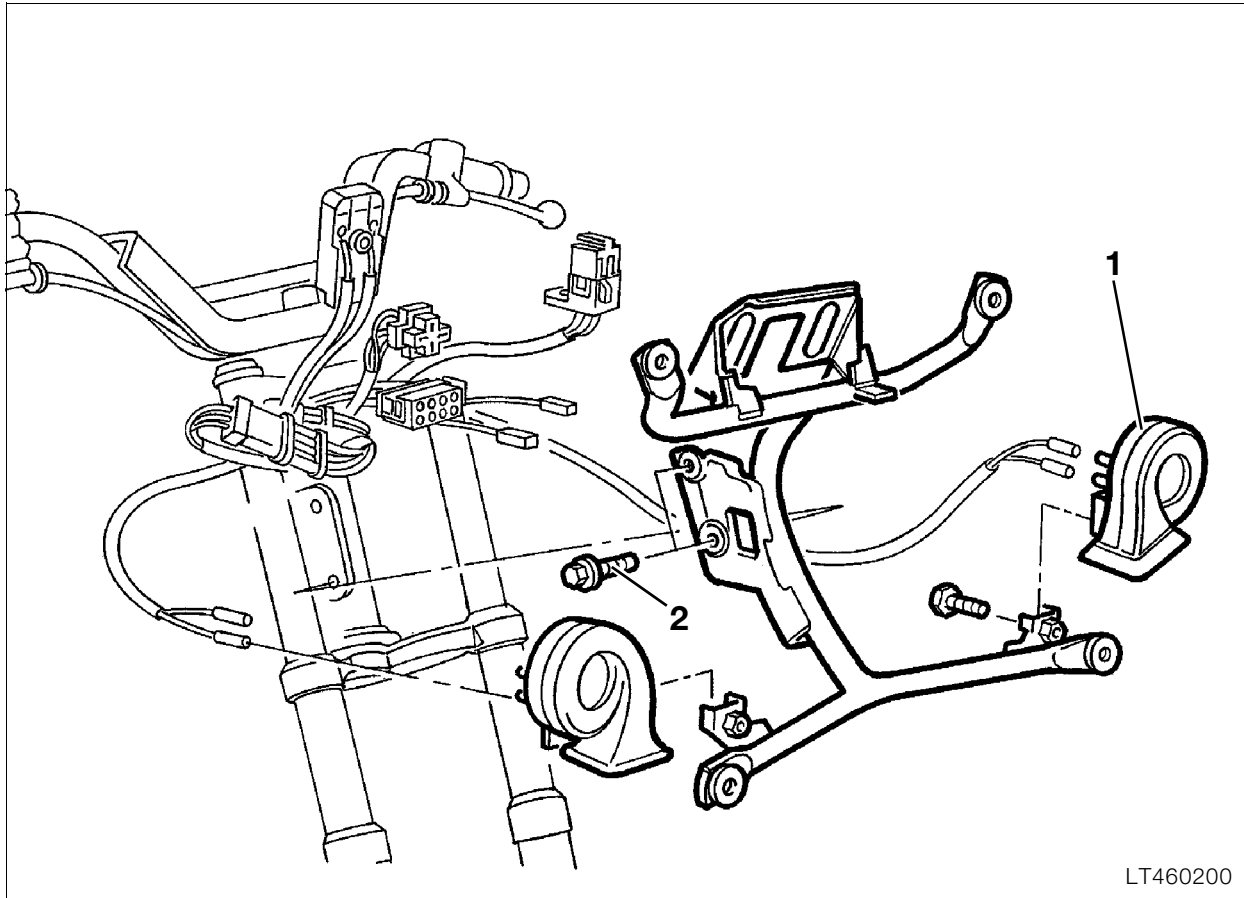

LT460200

Removing and installing fairing support bracket

- Remove fairing.
- **[LT]** Remove instrument cluster.
- Remove horns (1).
- Disconnect cable clips for wiring loom.
- Release securing screw (2).
- Install in the reverse order of removal.

Arrangement of cable clips [LT]

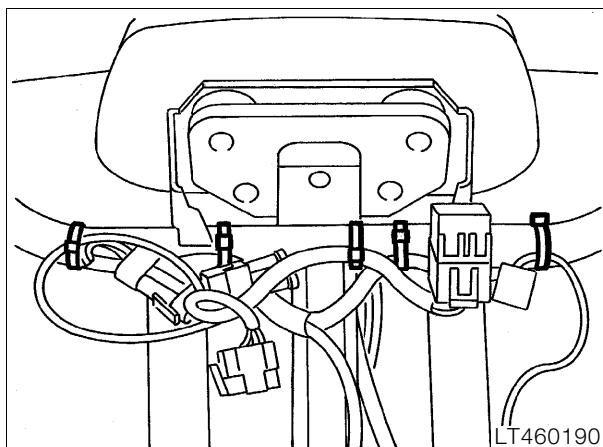

LT460190

Arrangement of cable clips [RS]

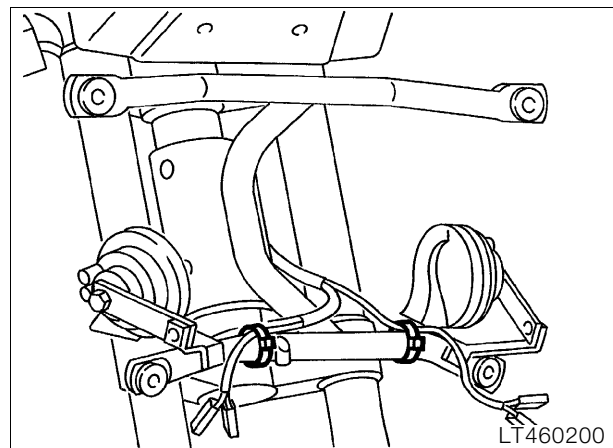

LT460200

Tightening torque:
 Fairing support bracket to frame 9 Nm

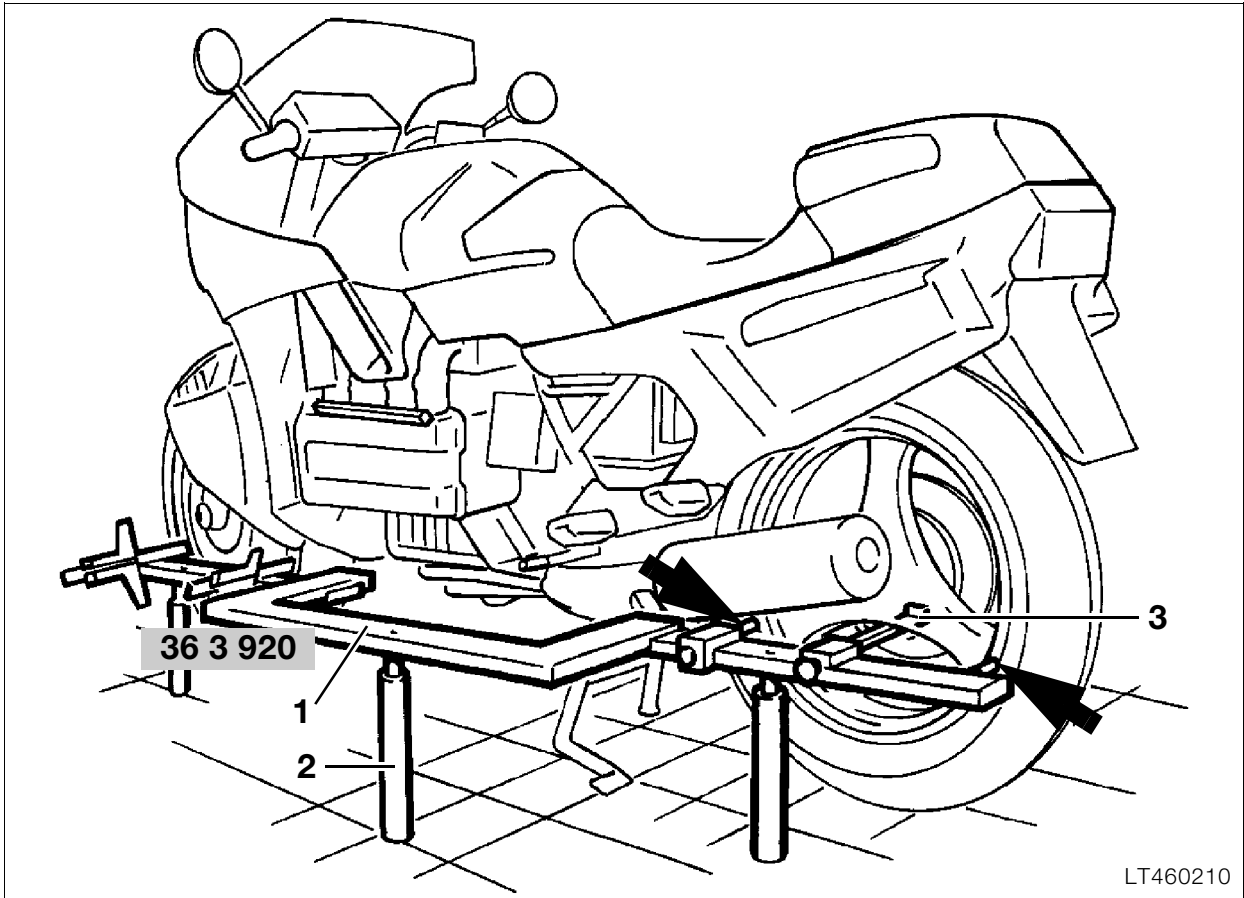

Checking running gear

Measuring track offset

- Mount motorcycle on centre stand on even base.
- Position track offset gauge (1), **BMW No. 36 3 920**, on left or right side of motorcycle.



Note:

In order to measure with the track offset gauge from the left or right side, the supports need only be screwed in from the other side.

- Adjust supports (2) so that the measuring level is as near as possible to the centre of the wheel. It must be possible to smoothly slide the gauge towards the motorcycle.
- Adjust limit stops (arrows) so that they only rest on the rim and not on the tyre.
- Attach hook (3) to wheel spoke and firmly pull gauge up to the wheel.
- Align front wheel parallel with respect to the gauge.
- Measure distance with depth gauge or straight edge from outer edge of gauge to rim and note down measurement.

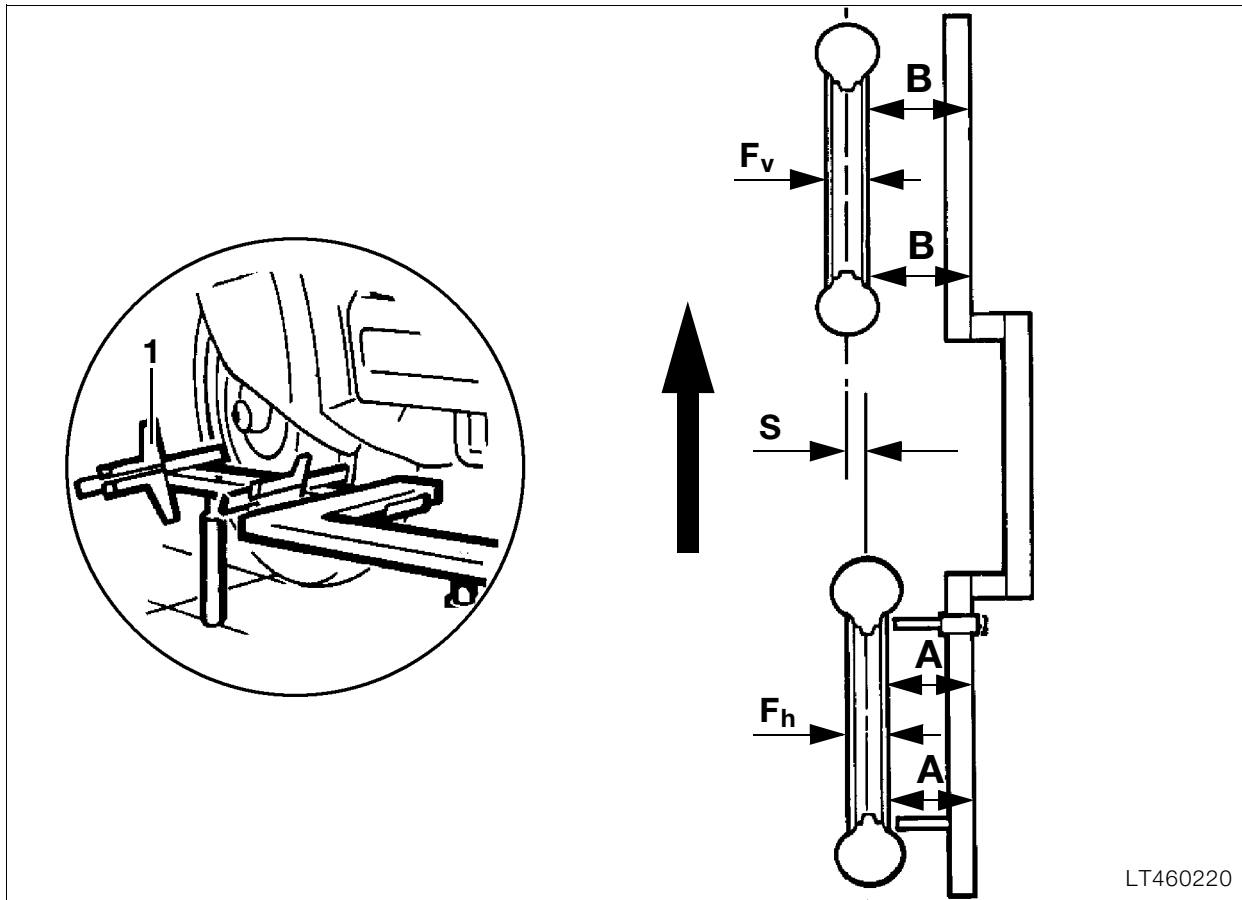

LT460220

- Calculate track offset "S":

EXAMPLE:

$$\text{Formula: } S = A + \frac{F_h}{2} - \left(B + \frac{F_v}{2} \right)$$

Fixed value „A“
(length of measuring stops)

$$A = 50,0 \text{ mm}$$

half of rear wheel rim width

$$\frac{F_h}{2} = 44,5 \text{ mm}$$

Measured value „B“

$$B = 52,0 \text{ mm}$$

half of front wheel rim width

$$\frac{F_v}{2} = 41,0 \text{ mm}$$

Track offset „S“

$$S = A + \frac{F_h}{2} - \left(B + \frac{F_v}{2} \right)$$

$$S = 94,5 \text{ mm} - 93,0 \text{ mm}$$

Track offset „S“ = 1,5 mm

- The track offset "S" represents the amount by which the longitudinal axis of the front wheel is offset to the left or right with respect to the rear wheel.

Permissible track offset:

S 12 mm



Note:

Significance of measurement result:

Negative sign = Track offset to left

Positive sign = Track offset to right



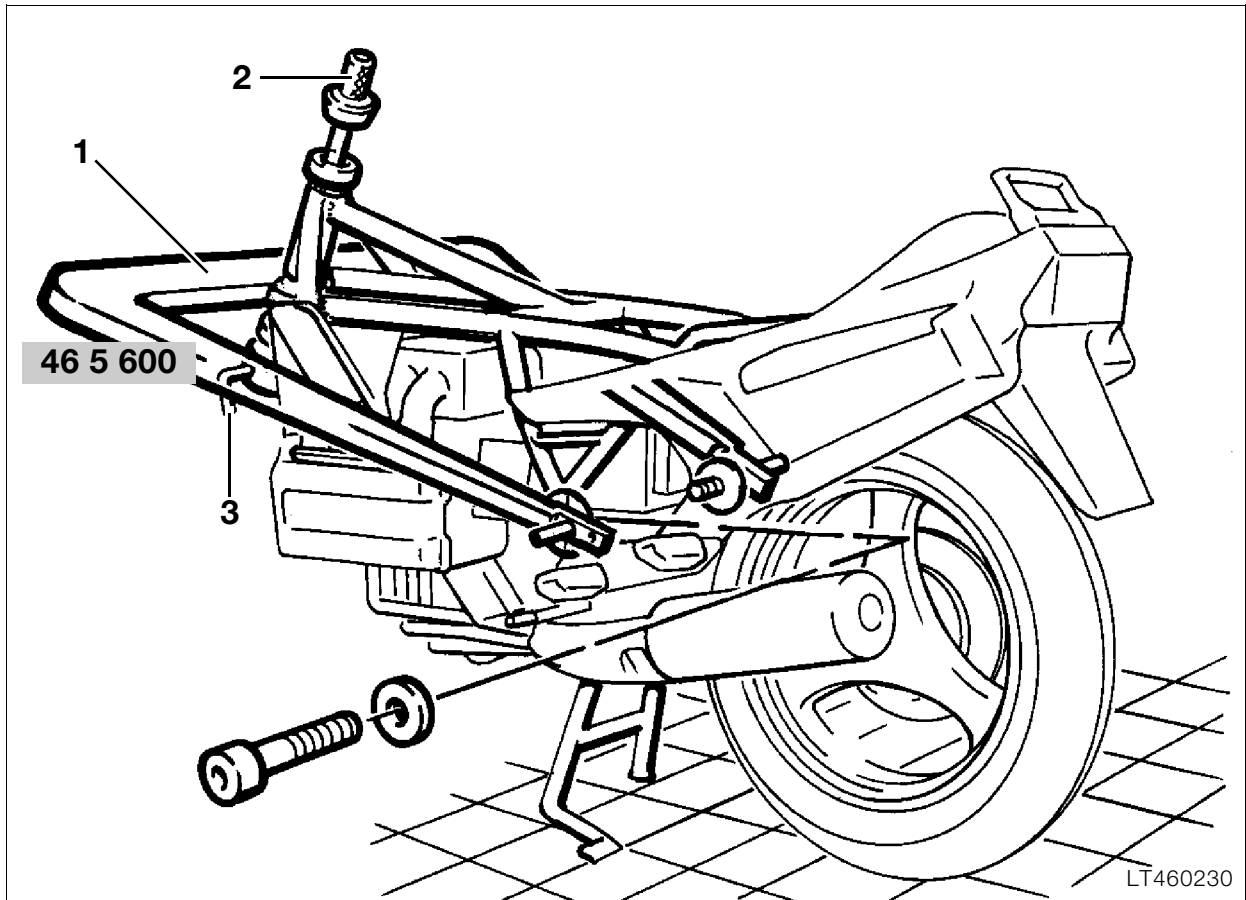

Checking frame with gauge

- Remove fairing.
- Support motor cycle with lifting gear, **BMW No. 00 1 510**.
- Remove telescopic fork.
- Outer bearing race at top and bottom remain in steering head.
- **[RS]** Remove left and right footrest plate.
- Release frame securing screw at gearbox.



Note:

After releasing the frame securing screw at the gearbox, check that the screws can be screwed in again easily.

If this is not possible, the frame is in all probability distorted.

- Fit adapter, **BMW No. 46 5 606**, instead of securing screws.
- Screw measuring discs, **BMW No. 46 5 603**, at the same level on the adapter.
- Connect frame test gauge (1), **BMW No. 46 5 600**, at bottom of steering head and clamp together frame and gauge with spindle (2), **BMW No. 46 5 604**, and crank (3).

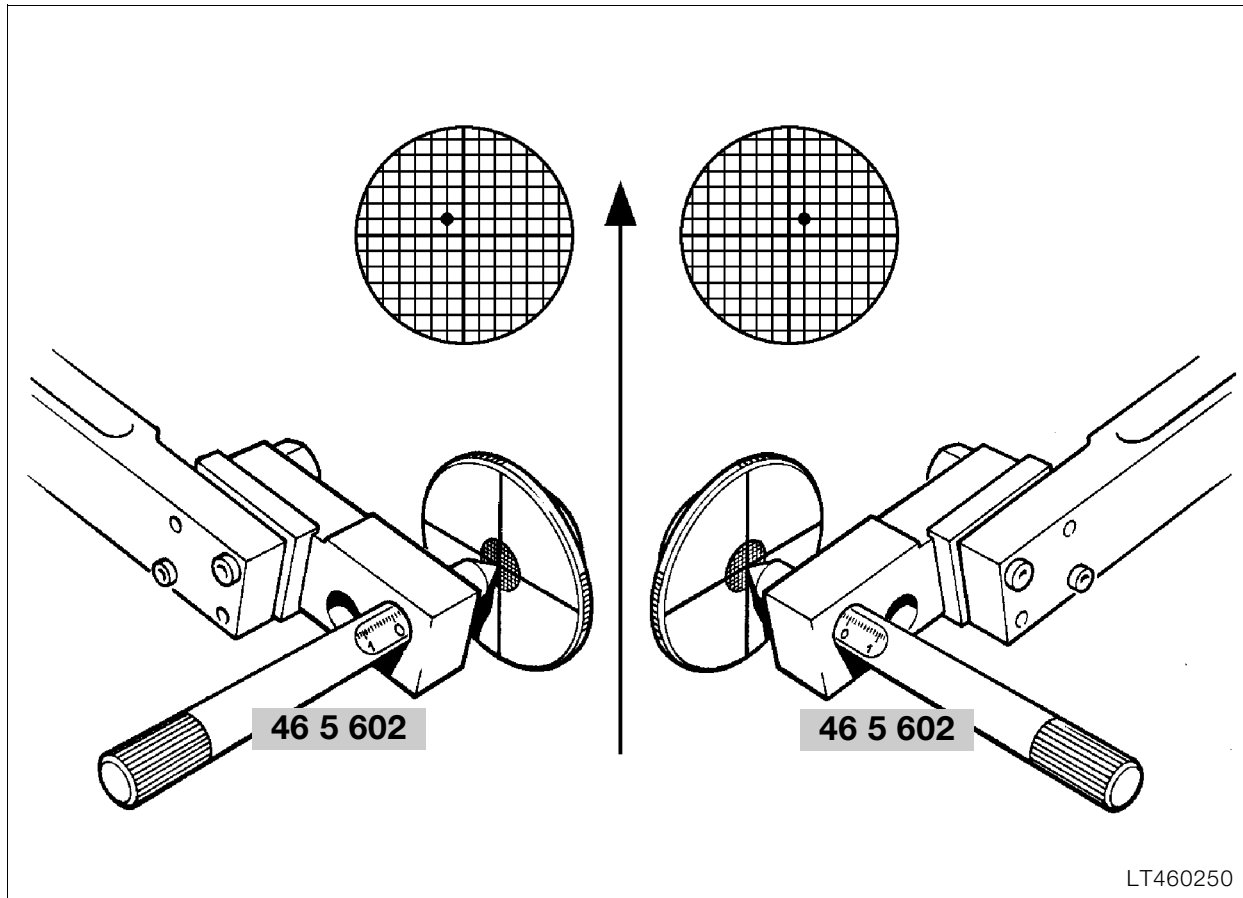

LT460250

- Fit measuring pins (1), **BMW No. 46 5 602**, lightly greased, in the outer holes.
- Slightly loosen nut on steering head and align gauge so that the same distance is obtained on the left and right with respect to the measuring discs.



Note:

The frame is in order when the tips of the measuring pins on the left and right are located in approximately the same position within the grid circle.

Max. deviation:

Left to right 2 mm (0.0787 in) = 2 boxes



Caution:

The frame must be replaced if the deviation is greater than the permissible tolerance. Straightening the frame of the K model is not approved by the manufacturer.

Removing and installing frame

Removing frame

- Set motorcycle on centre stand.

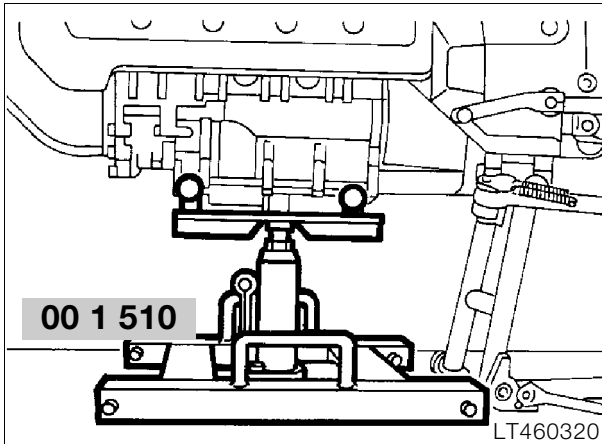

- Support with lifting gear, **BMW No. 00 1 510**, under oil sump.
- Remove seat.
- Remove rear section.
- Remove rear mudguard.
- Remove fuel tank.
- Remove fairing complete.
- Remove fairing support bracket.
- Remove radiator.
- Drain the brake system.
- Release brake line at hand brake cylinder, close off line and brake fluid reservoir.
- Remove handlebar with multifunction switches, detach cables.
- Remove telescopic fork complete with front wheel.
- Remove rear protective plate with coolant reservoir.
- Remove Motronic control unit.
- **[ABS I]** Remove ABS control unit.
- Remove battery.
- **[ABS I]** Remove ABS pressure modulators.
- **[ABS I]** Remove ABS brake line, front pressure modulator.
- Remove footrest plates.
- **[ABS II]** Detach front brake lines at ABS unit.
- Remove spring strut.
- Release frame at engine and lift off.
- Remove frame wiring loom with central electrics box.
- **[ABS II]** Remove front brake lines.
- Dismantle/assemble frame.

Disassembling and assembling frame

- Remove all rubber mounts and cage nuts on frame.

Removing outer bearing race in steering head

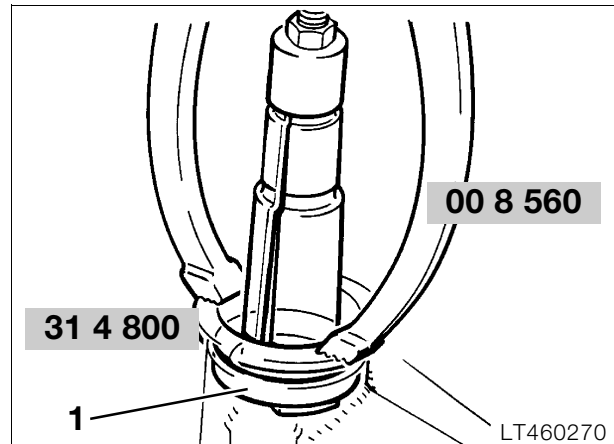

- Remove outer bearing race (1) at top and bottom with inner extractor, **BMW No. 00 5 560** in conjunction with support ring, **BMW No. 31 4 800**.



Caution:

Bearing and outer bearing race belong together, do not interchange and only renew together!

Installing outer bearing race in steering head

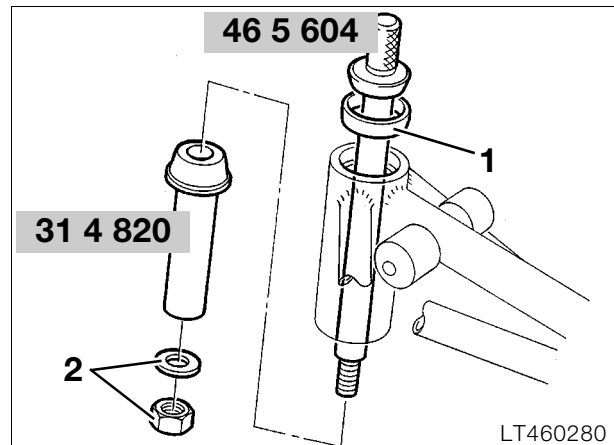

- Fit outer bearing race (1) top/bottom with spindle, **BMW No. 46 5 604**, from frame test gauge, **BMW No. 46 5 600**, and spacer, **BMW No. 31 4 820**, with washer and hexagon nut (2).



Note:

If a bearing shell has been removed, immediately install the new shell otherwise there will be no guide for the second bearing shell.

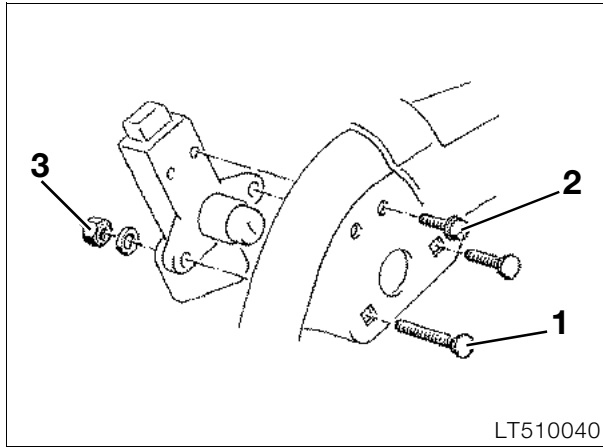

Removing and installing seat lock

1. Saucer-head screw
2. Phillips-head screw
3. Stop nut

Removing and installing handle

- Lever out spring using screwdriver, remove spring seat.
- Detach handle.
- Remove spring with second spring seat.
- Install in the reverse order of removal.



Note:

Grease the pivot point a little before installing handle. Spring seats must engage in the grooves.



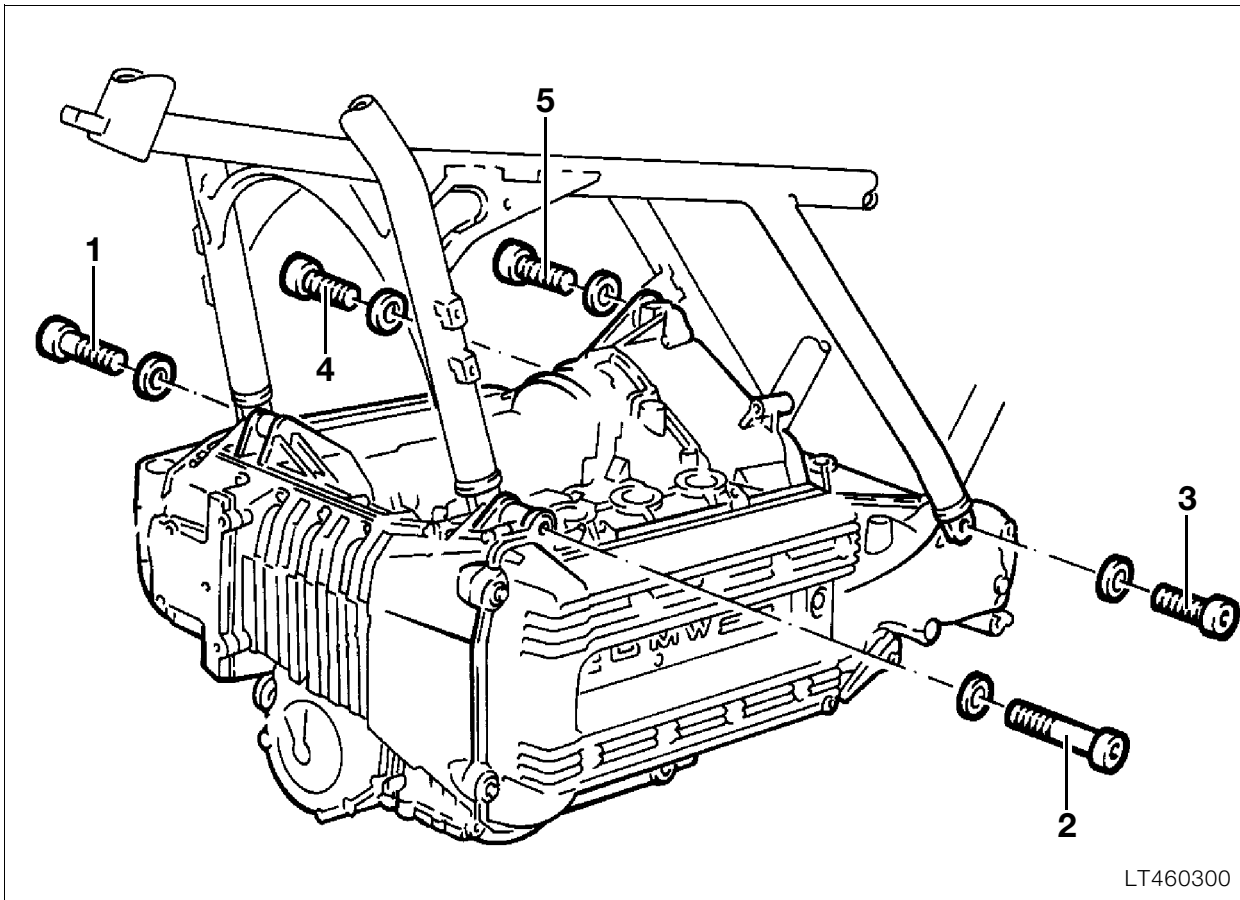

LT460300

Installing frame

- Installation basically takes place in the reverse order of removal.
 - Place frame on drive train and firmly tighten screws and bolts in the specified order.
1. Screw in all 5 screws loosely, i.e. not as far as they will go. Fit a 1 mm thick spacer ring, inner support ring at the front right between the cylinder head and frame strut.
 2. Firmly tighten screws 1,4 and 3.
 3. Measure distance at front left and fit outer support ring, firmly tighten screws.
 4. Measure distance of mounting point on intermediate flange and firmly tighten screw.

Tightening torque:
 Frame to engine 45 Nm

- Install telescopic fork and adjust steering.

Setting torque:
 Hexagon nut..... 12 Nm

New bearing adjustment procedure:
 Pre-tighten hexagon nut to..... 25 Nm
 Move steering from stop to stop several times,
 loosen hexagon nuts, retighten 12 Nm

Tightening torques:
 Locking tube 65 Nm
 Hexagon nut 65 Nm
 Clamping screws of fork bridge..... 15 Nm
 Clamping block for handlebar 22 Nm

Setting dimensions:
 Clutch play at handlebar
 lever 4 ± 0,5 mm (0.157 ± 0.0197 in)
 Cable length at clutch release
 lever 75 ± 1 mm (2.953 ± 0.04 in)
 Accelerator cable play..... 0,75 mm (0.0295 in)

- Carefully fill and bleed brake system

Tightening torques:
 Brake line to handbrake cylinder 11 Nm
 Brake line to distributor 11 Nm
 Brake line to brake caliper..... 7 Nm
 Bleed screw 7 Nm
[ABS II] Pressure modulator to holder 17 Nm

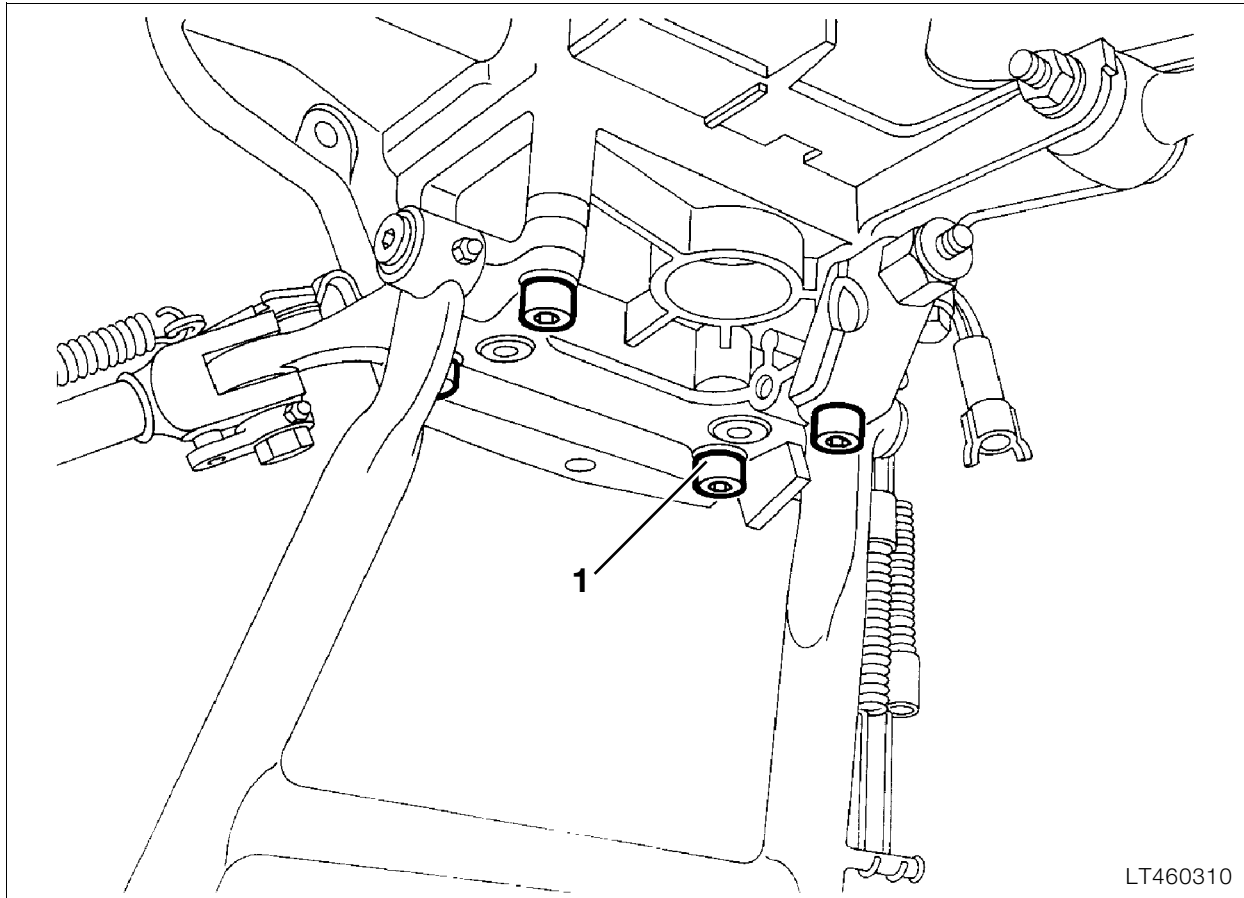

LT460310



Removing and installing main centre stand

- [RS] Remove lower section of fairing.

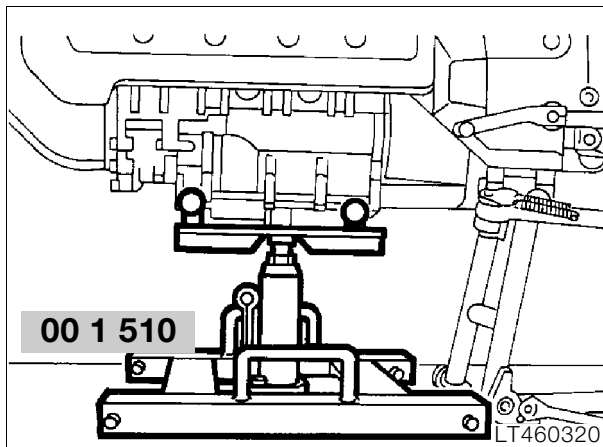

- Raise motorcycle with lifting gear, **BMW No. 00 1 510**, under the oil sump until stand is free to move.
- Disconnect cable clips for side stand line.

- Release retaining screws (1) and detach main stand together with side stand.
- Install in the reverse order of removal.



Note:

The retaining screws are micro-encapsulated and can therefore not be re-used. Clean thread and holes. Fit screws with **Loctite 243**.

Line arrangement for side stand

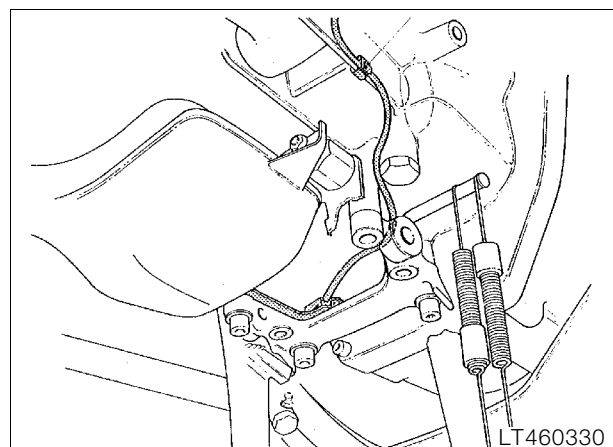

Tightening torque:

Main stand to bearing block..... 41 Nm

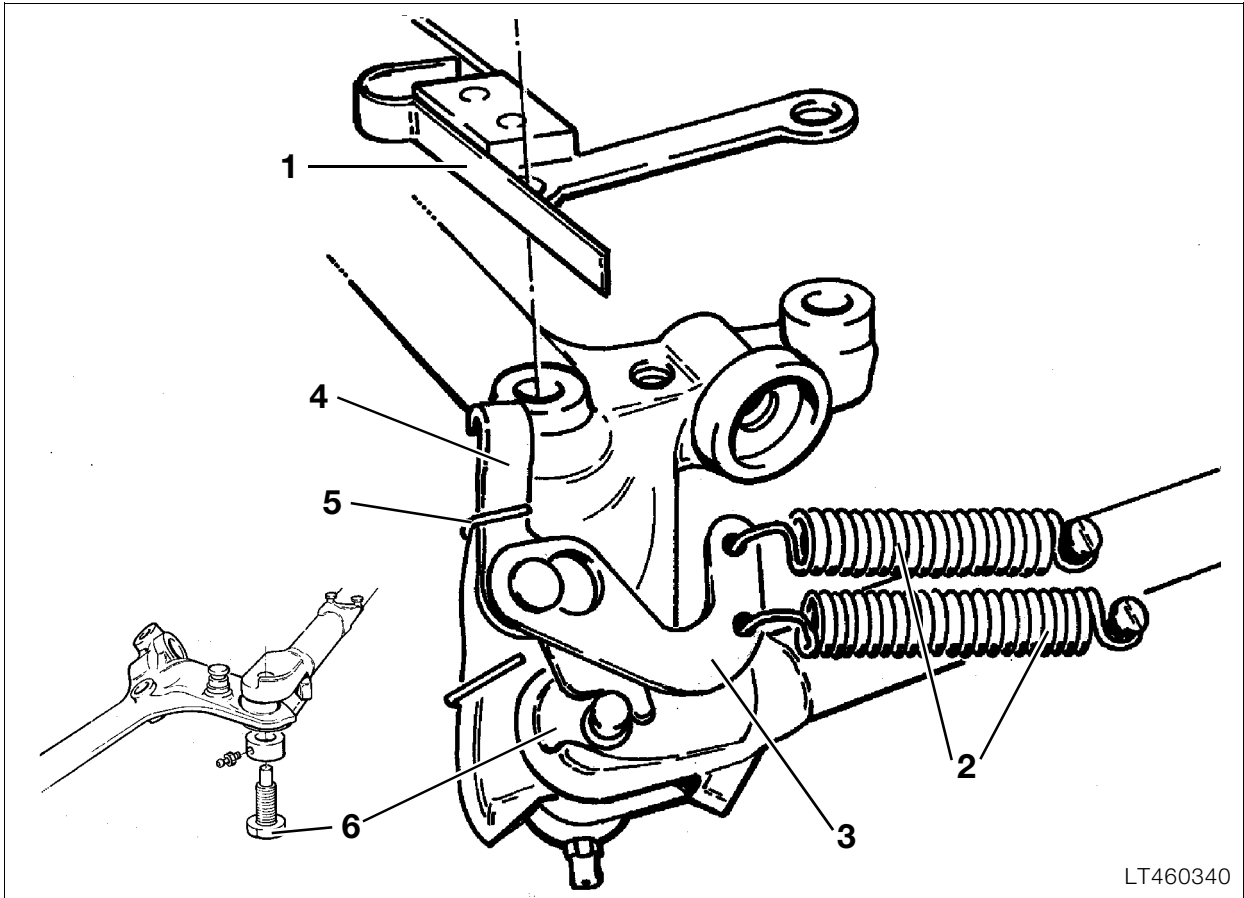

Disassembling and assembling side stand

Disassembling side stand

- Detach switch (1).
- Detach tension springs (2).
- Remove bracket (3) with spring.
- Remove operating hook (4).
- Remove leg spring (5).
- Release securing screw (6) of side stand.

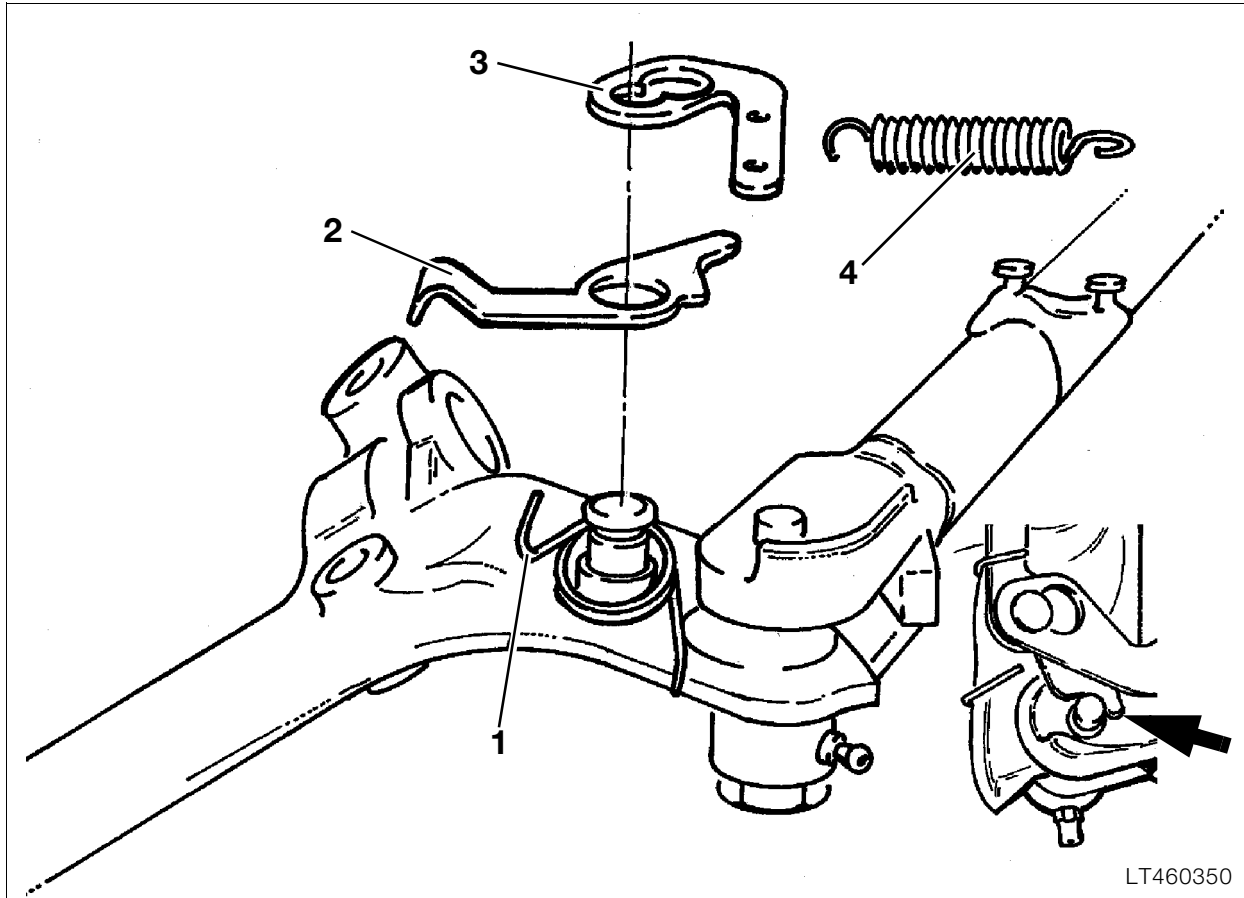

Assembling side stand



Note:

The securing screw of the side support is micro-encapsulated and cannot be reused. Clean thread and holes. Coat screws with **Loctite 243** before inserting.

- Fit securing screw (6) with **Loctite 243**.
- Fit leg spring (1) as illustrated.
- Install operating hook (2) and bracket (3), note installation position (arrow).



Caution:

Do not grease operating hook and bracket, increased dirt accumulation!

- Attach tension springs (4).

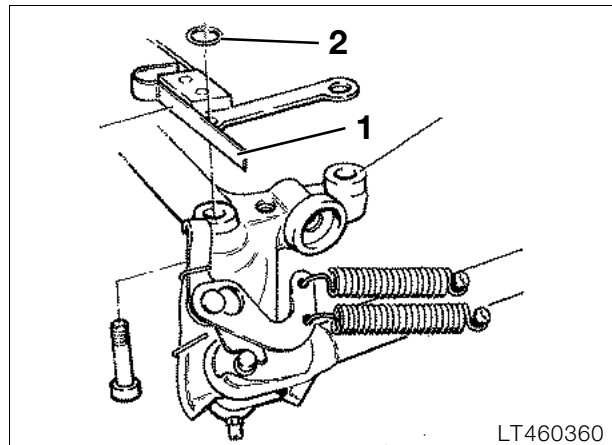

- Prior to installation, check condition of switch, contact spring must not be bent.
- In no-load condition, there must be an air gap (clearance) between the contact spring (1) and contact point on the switch.
- Secure switch with 2 O-rings (2) on the retaining screws for the bearing block.
- Install stand with side stand.



Tightening torque:

Side stand to bearing block 41 Nm

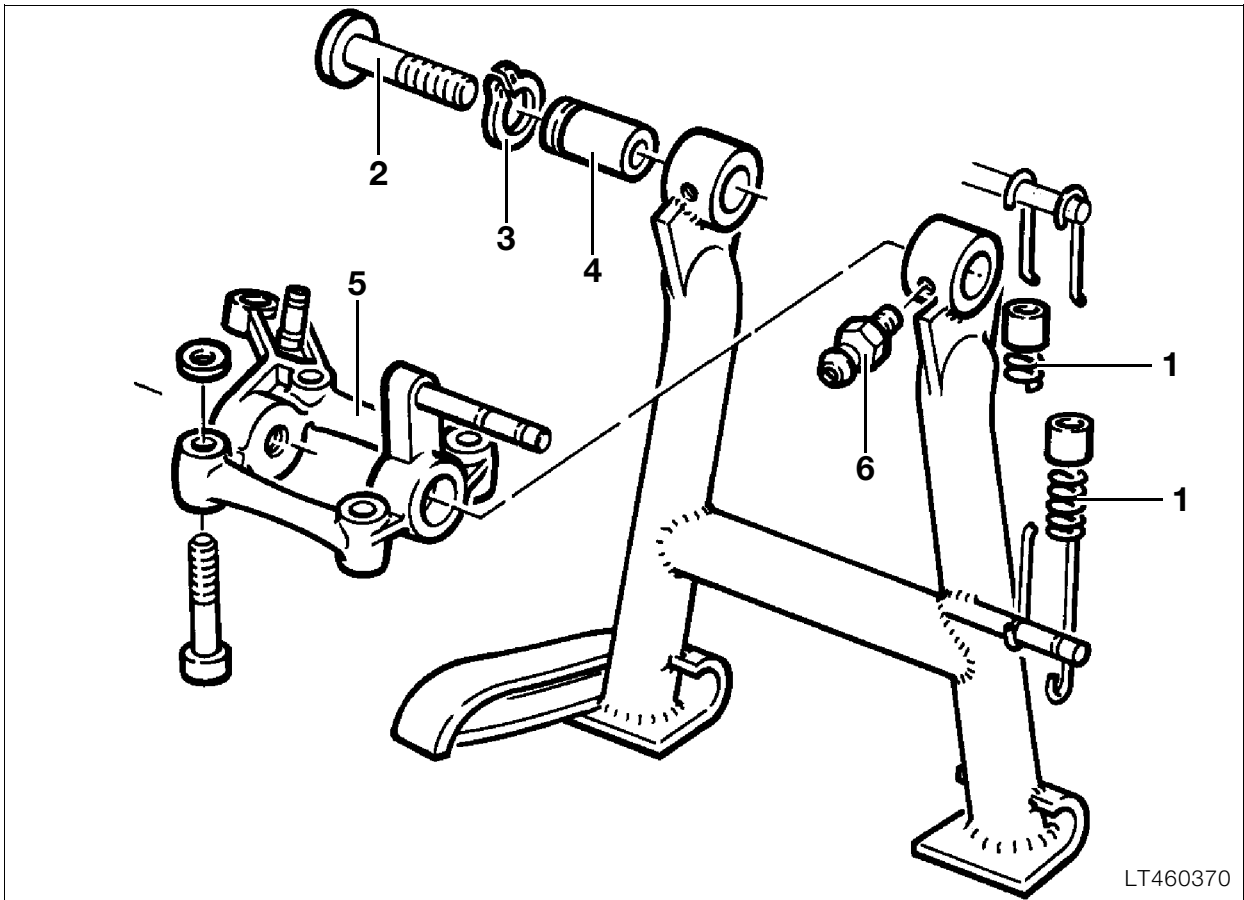

LT460370

Disassembling and assembling main centre stand

- Detach tension springs (1).
- Release screws (2) on left/right.
- Release retaining ring (3).
- Press out sleeve (4) on left/right.
- Remove bearing block (5).
- Loosen grease nipple (6).
- Assemble in the reverse order of disassembly.



Note:

Screws (2) are micro-encapsulated and must therefore not be re-used. Clean threads and holes and fit screws with **Loctite 243**.

Lubricate sleeves with **SHELL RETINAX A**.

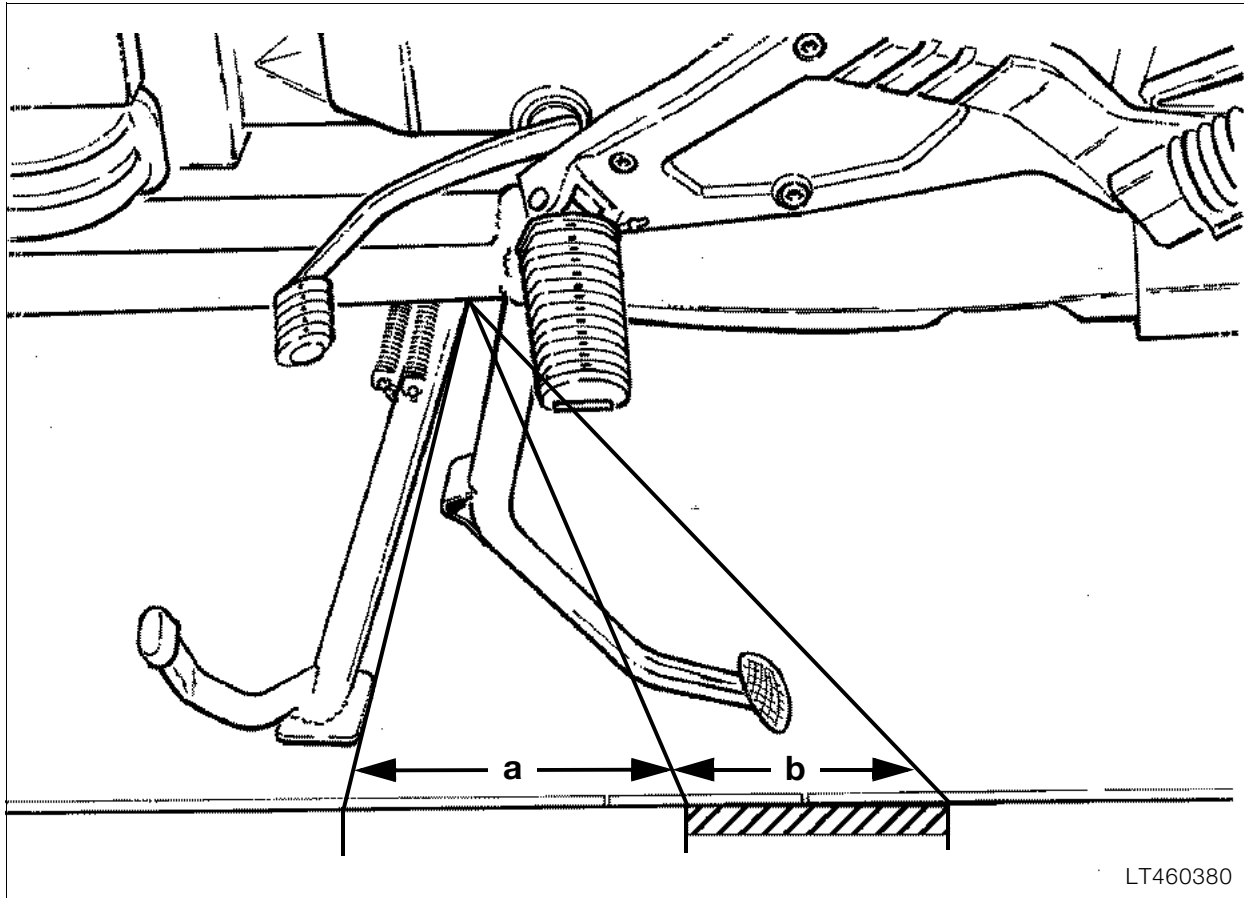

Checking switching function of side stand

- Set vehicle on centre stand on even base or lifting platform.
- Spray switching kinematics of side stand with quick-action cleaner and fold out and in several times.
- Completely fold out side stand and mark position on the base.
- Make a second marking at the distance "a" and a third marking at the distance "b".
- Operate starter while slowly folding in side stand, the engine must start up in area "b".
- If the engine does not start up, or if the side stand is difficult to move, check the switch or disassemble the side stand.

Distances:

"a" 95 mm (3.74 in)
 "b" 50 mm (1.97 in)

- Fold in side stand and start engine.
- Slowly fold out side stand, the engine must cut out in the area of dimension "b".
- If the engine does not cut out, check or replace the switch.



Caution:

Bending the contact spring can cause switch malfunctions.

Therefore:

Never bend the contact spring!



51 Equipment

Contents

Page

Removing and installing ignition switch/steering lock	3
Removing and installing lock cylinder for fuel tank	4
Removing lock cylinder	4
Installing locking cylinder	4
Removing lock cylinder with broken key	4
Removing and installing dualseat lock	5



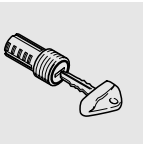

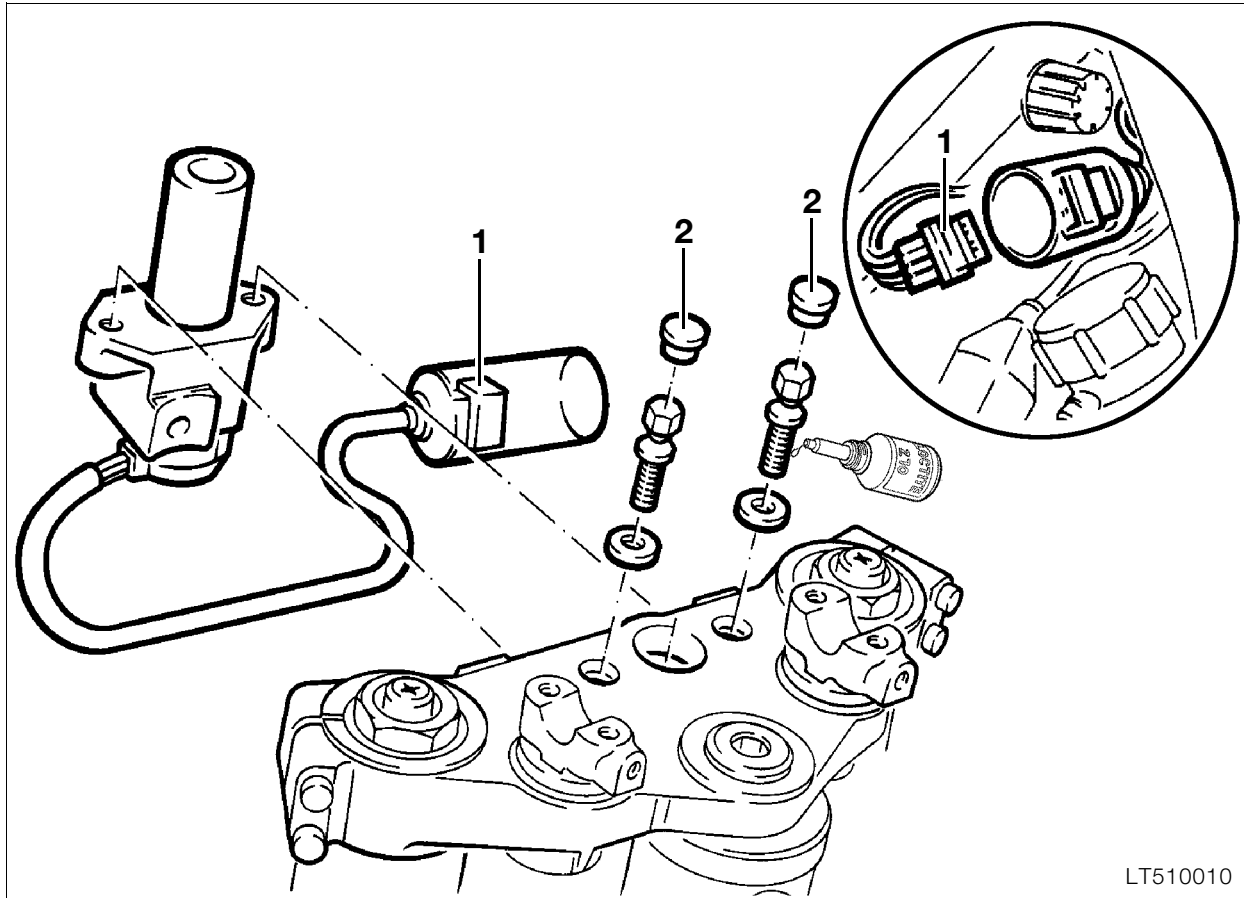

Removing and installing ignition switch/steering lock

- Remove fuel tank.
- Disconnect plug connection (1) for ignition switch/steering lock.
- Detach crash pad on upper fork bridge.
- Loosen handlebar clamping blocks and place handlebar on frame.
- Remove screw plugs (2).

- With 4 mm drill, drill shear bolt to a minimum depth of 10 mm.
- With an 8 mm drill, drill shear bolt to a minimum depth of 8 mm.
- Remove lock barrel from below.
- Install in the reverse order of removal.



Caution:

Secure shear bolts with **Loctite 270**.



Tightening torques:

Handlebar clamping blocks..... 22 Nm
 Shear bolts..... to shear point (~ 20 Nm)

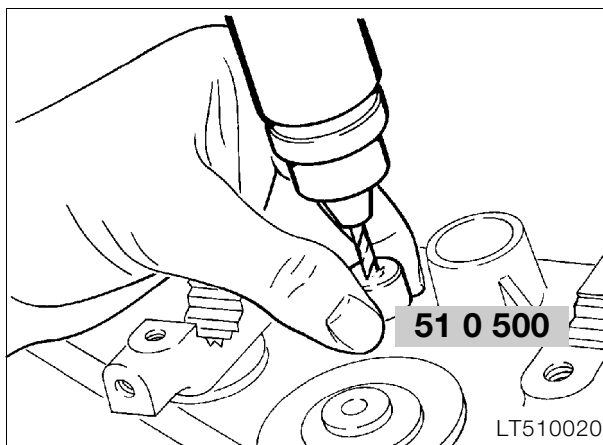

- Fit drilling bushing (1), **BMW No. 51 0 500**, in hole.



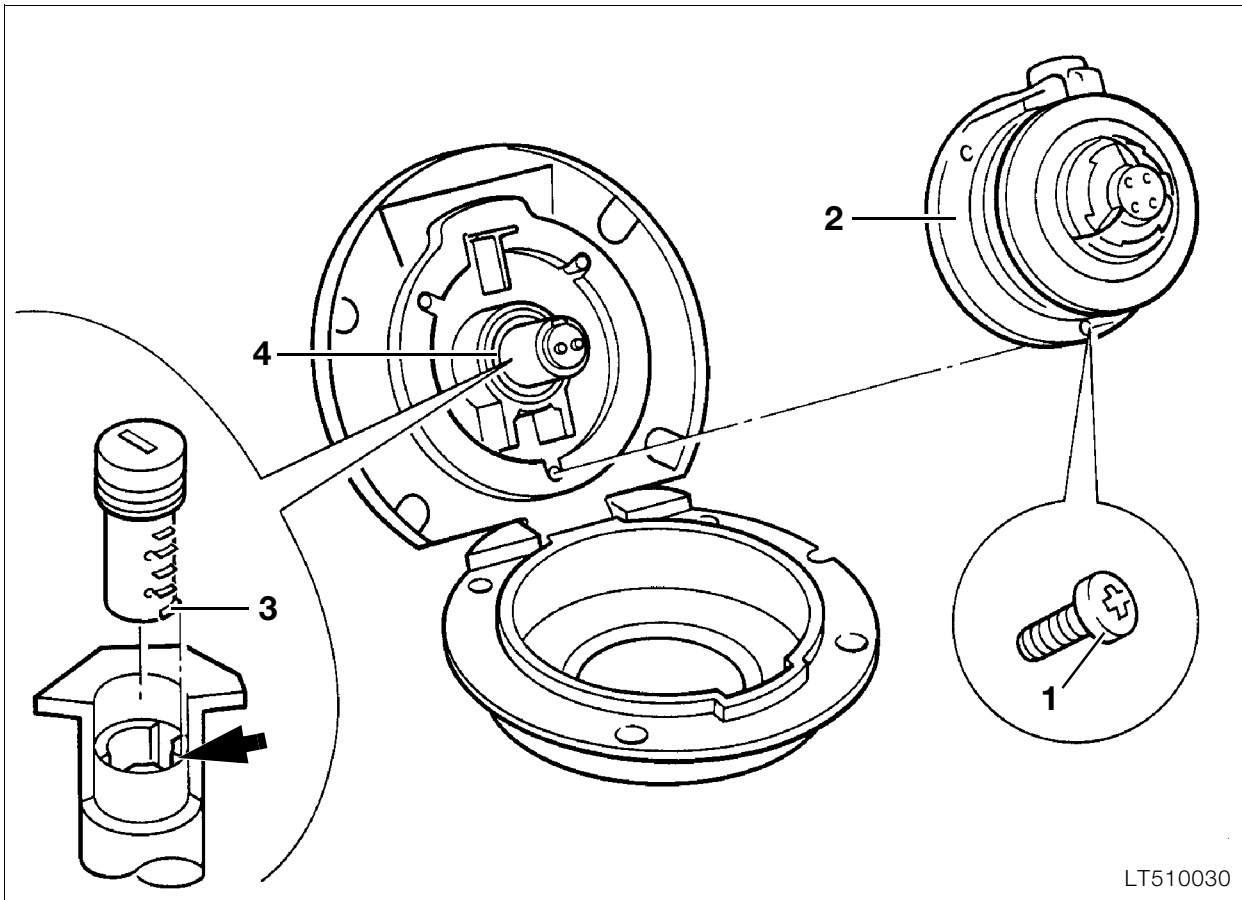

Removing and installing lock cylinder for fuel tank

Removing lock cylinder

- Open cover and release screws (1).
- Remove housing (2) for lock cylinder.
- Fit key in lock cylinder, press catch (3).
- Pull out lock cylinder together with key.
- Note position of O-ring (4).

Installing locking cylinder

- Grease lock cylinder with **Shell Retinax A**.
- Fit lock cylinder with key in mounting groove (arrow).
- Press down lock cylinder and turn key in clockwise direction; catch engages.
- Install housing.

Removing lock cylinder with broken key

- With the aid of 4-5 mm Ø drill, drill out lock cylinder over its entire length.
- Increase drill Ø until the lock cylinder can be removed.



Caution:

Clean fuel tank of drilling swarf.

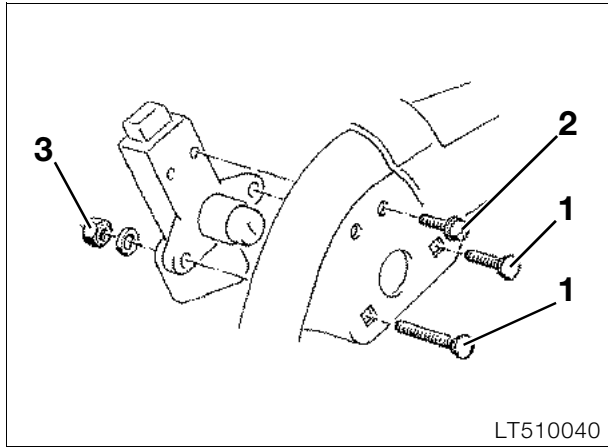

Removing and installing dual seat lock

5. Saucer-head screw
6. Phillip-head screw
7. Stop nut



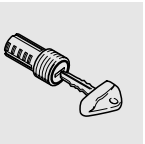

61 General electrical equipment

Contents

Page

Technical Data	3
Removing and installing Motronic control unit	5
[ABS I] Removing and installing control unit	6
[ABS II] Removing and installing control unit	6
Removing and installing battery	7
Relay locations (central electrical unit)	8
Locations and connections, ABS wiring loom	9
Locations, frame wiring loom	10
View from left	10
Wiring arrangement, fairing bracket, [LT]	10
View from right	11
Wiring arrangement fairing bracket, [RS]	11



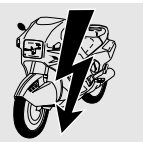

Technical Data	K 1100 LT	K 1100 RS
Battery	Ah 19	

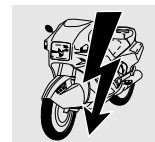

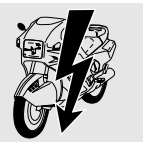

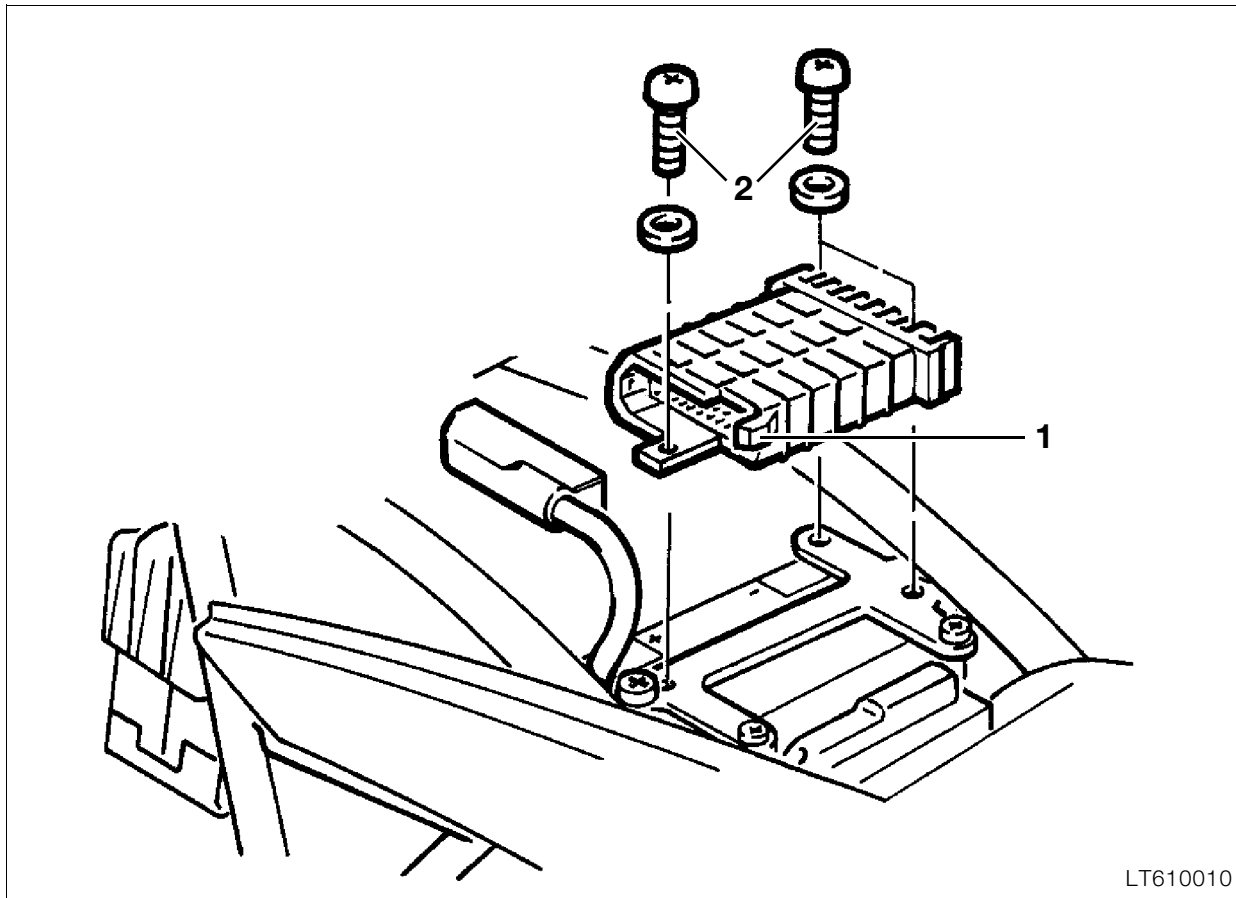

LT610010

Removing and installing Motronic control unit



Caution:

Switch off ignition, disconnect and insulate earth (ground) lead!

- Open dualseat.
- Press catch (1) for multi-pin plug and detach plug.
- Loosen screws (2) and remove control unit.



Tightening torque:

Motronic control unit 5 Nm

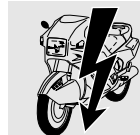

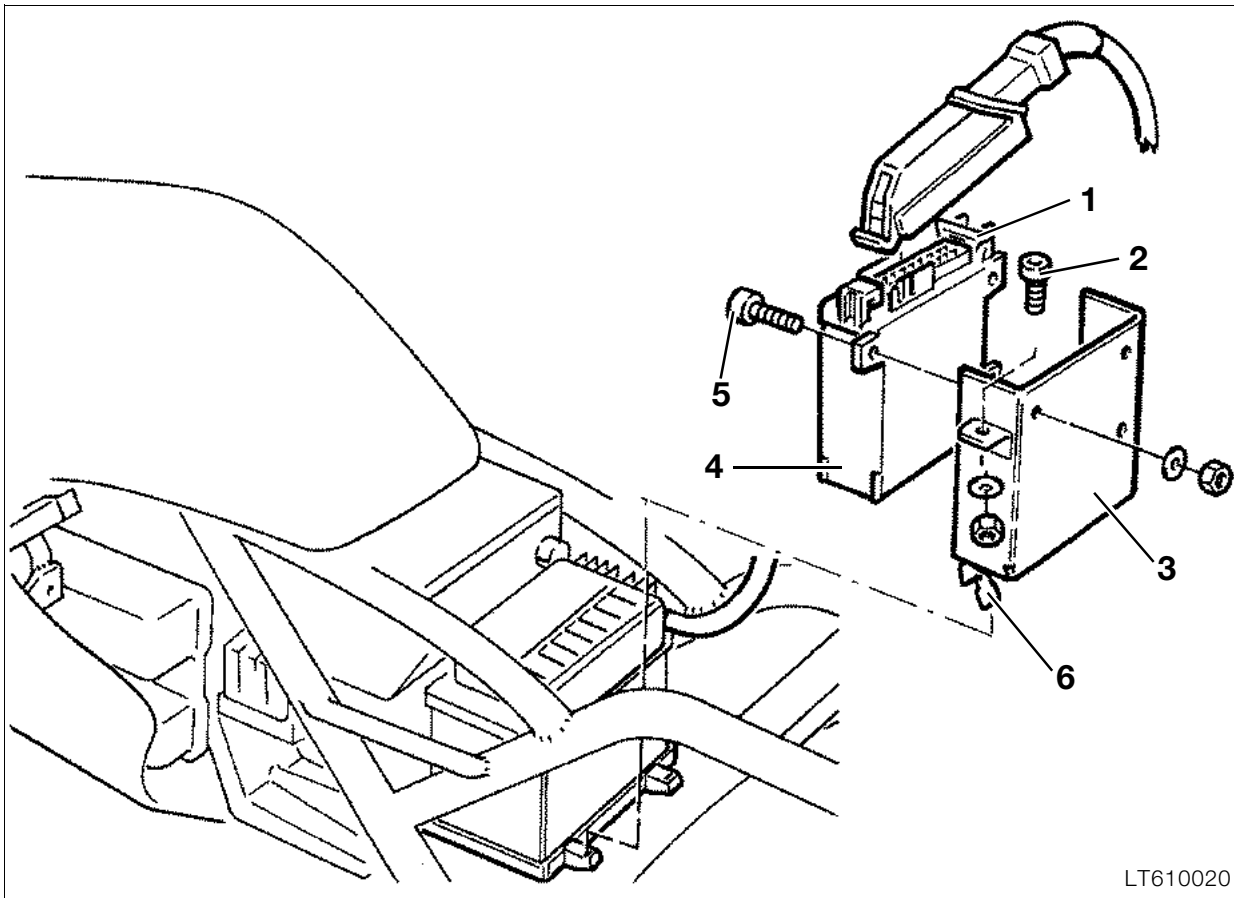

LT610020

[ABS I] Removing and installing control unit

⚠ Caution:

Switch off ignition, disconnect and insulate earth (ground) lead!

- Switch off ignition, disconnect and insulate ground lead!
- Open dualseat.
- Press catch (1) for multi-pin plug and detach plug.
- Loosen screws (2) at left and right and remove housing (3) together with control unit.
- Remove ABS control unit (4) from housing (5).
- Install in the reverse order of removal.

📖 Note:

Ensure that lug (6) on housing (3) is fitted correctly in the battery support bracket.

[ABS II] Removing and installing control unit

📖 Note:

[ABS II] The control unit is on the pressure modulator. For removal, see Group 34 "Removing and installing ABS unit".

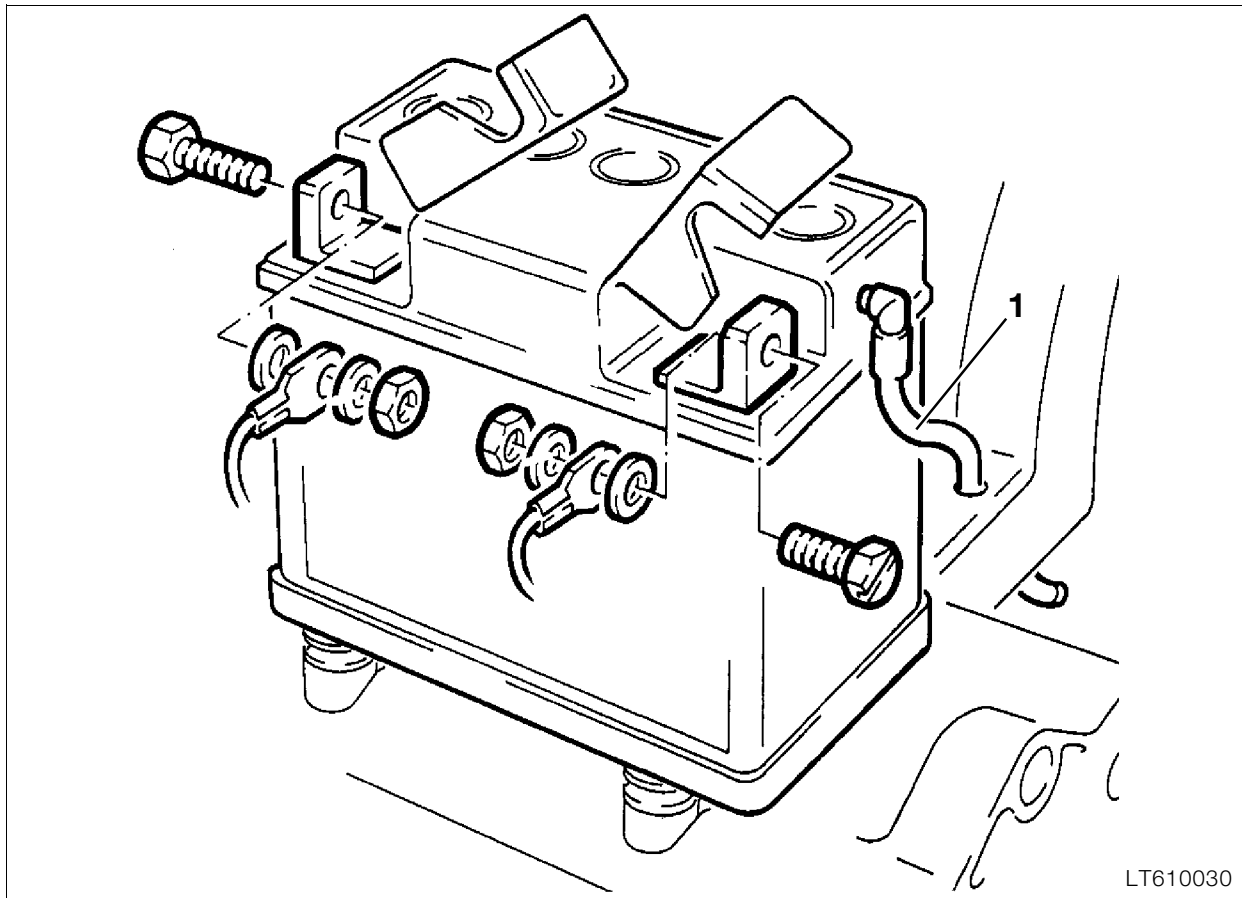

LT610030

Removing and installing battery



Caution:

Switch off ignition, disconnect and insulate ground lead!

- Remove Motronic control unit.
- **[ABS I]** Remove ABS control unit.
- Disconnect positive lead.
- Detach vent hose (1).
- Install in the reverse order of removal.



Note:

First connect positive pole, followed by negative pole. Coat battery terminals with acid-free grease. Fit battery vent hose without kinks.



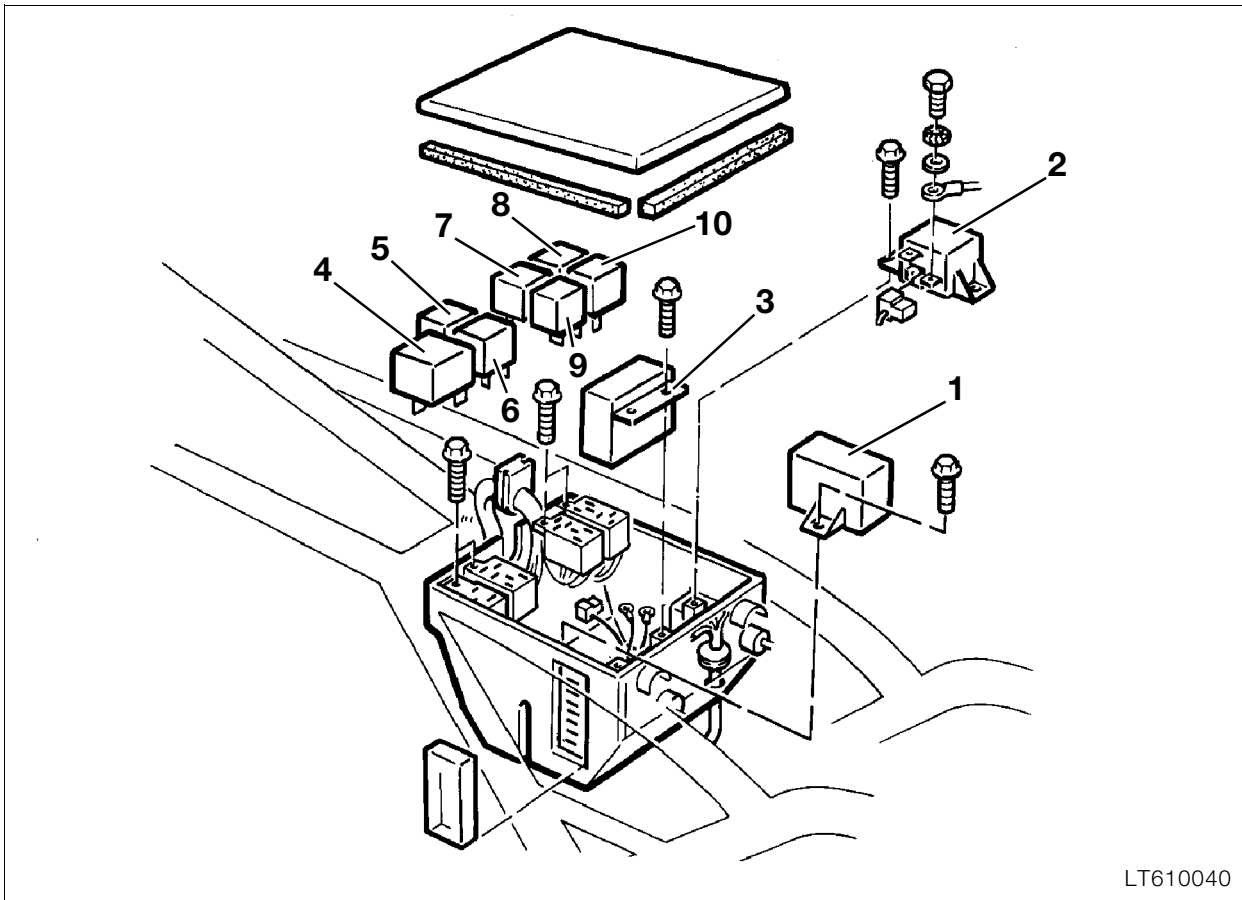

LT610040

Relay locations (central electrical unit)

- First remove the fuel tank in order to remove a relay.

1. Lamp control unit
2. Start relay
3. Turn indicator relay
4. **[ABS I]** ABS relay



Note:

With **ABS II** the relay is on the ABS unit. See Group 34 "Removing and installing ABS relay base".

5. Motronic relay
6. ABS warning relay
7. Fan relay
8. Horn relay
9. Fuel pump relay
10. Load relief relay

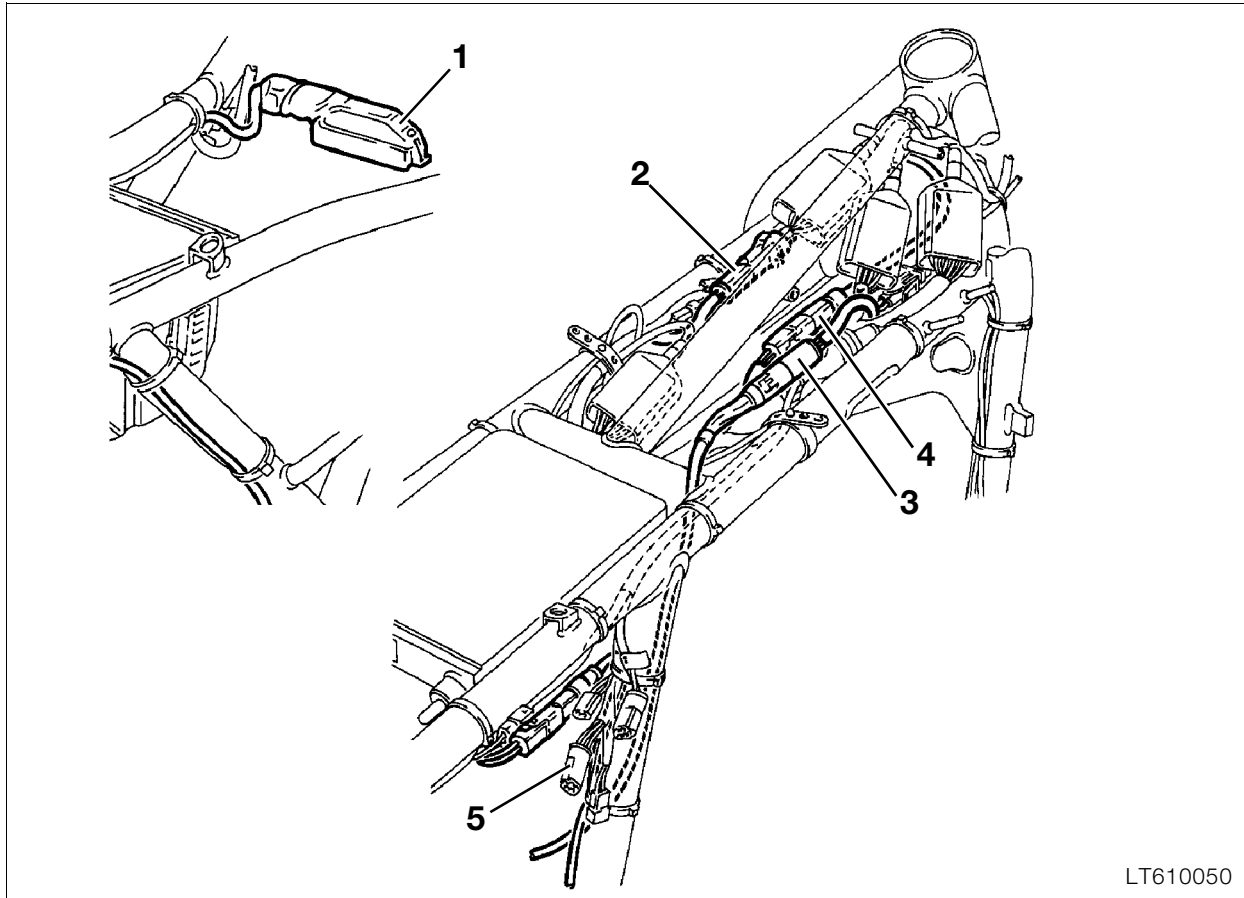

LT610050

Locations and connections, ABS wiring loom



Note:

All ABS plug connections are blue.

1. **[ABS I]** Multi-pin plug, ABS control unit
2. **[ABS I]** Plug connection, front pressure modulator
3. **[ABS I]** Plug connection, rear pressure modulator
4. Plug connection, front sensor
5. Plug connection, rear sensor



Note:

[ABS II] See Group 34.



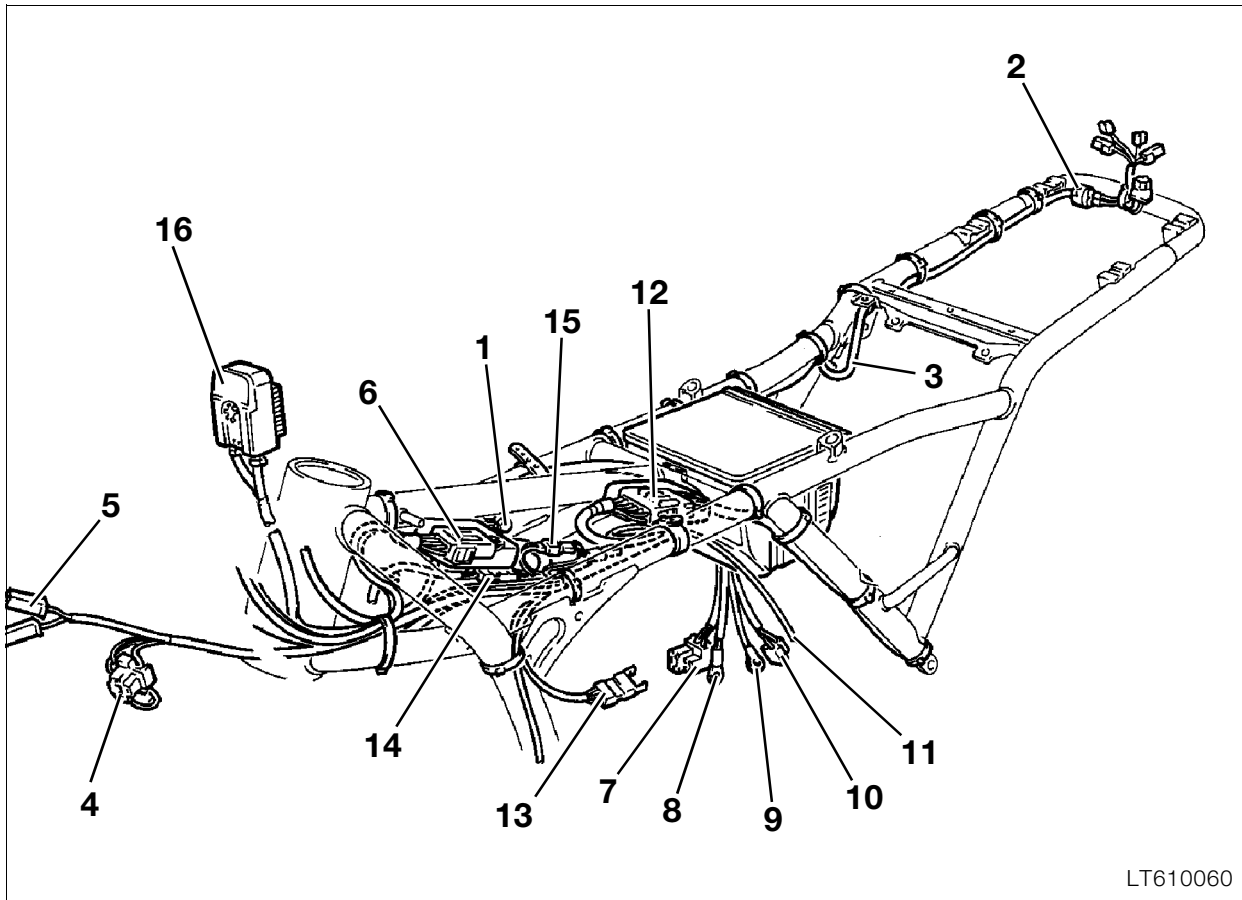

LT610060

Locations, frame wiring loom

View from left

Wiring arrangement, fairing bracket, [LT]



Note:

When removing the wiring loom, also remove the central electrical box together with the wiring loom.

1. Central earth (ground) at frame
2. Plug connection for tail light
3. Equalisation loop
4. Headlight connection
5. Parking light connection
6. Left multifunction switch connection
7. Alternator connection
8. Battery connection (positive)
9. Starter connection
10. Socket connection
11. Choke line
12. Plug connection, engine wiring loom
13. Auxiliary instrument connection
14. Fan plug connection
15. Clutch switch plug connection
16. Instrument cluster connection

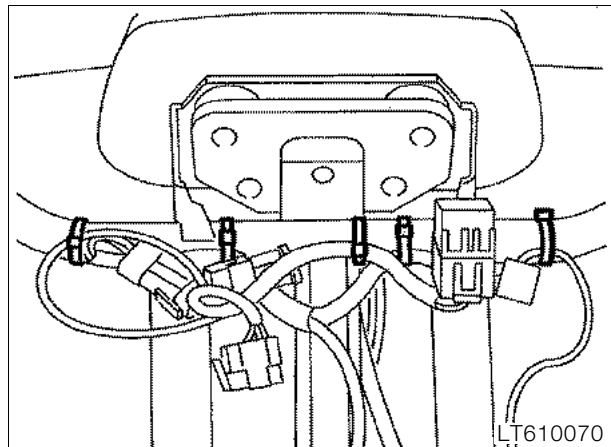

LT610070

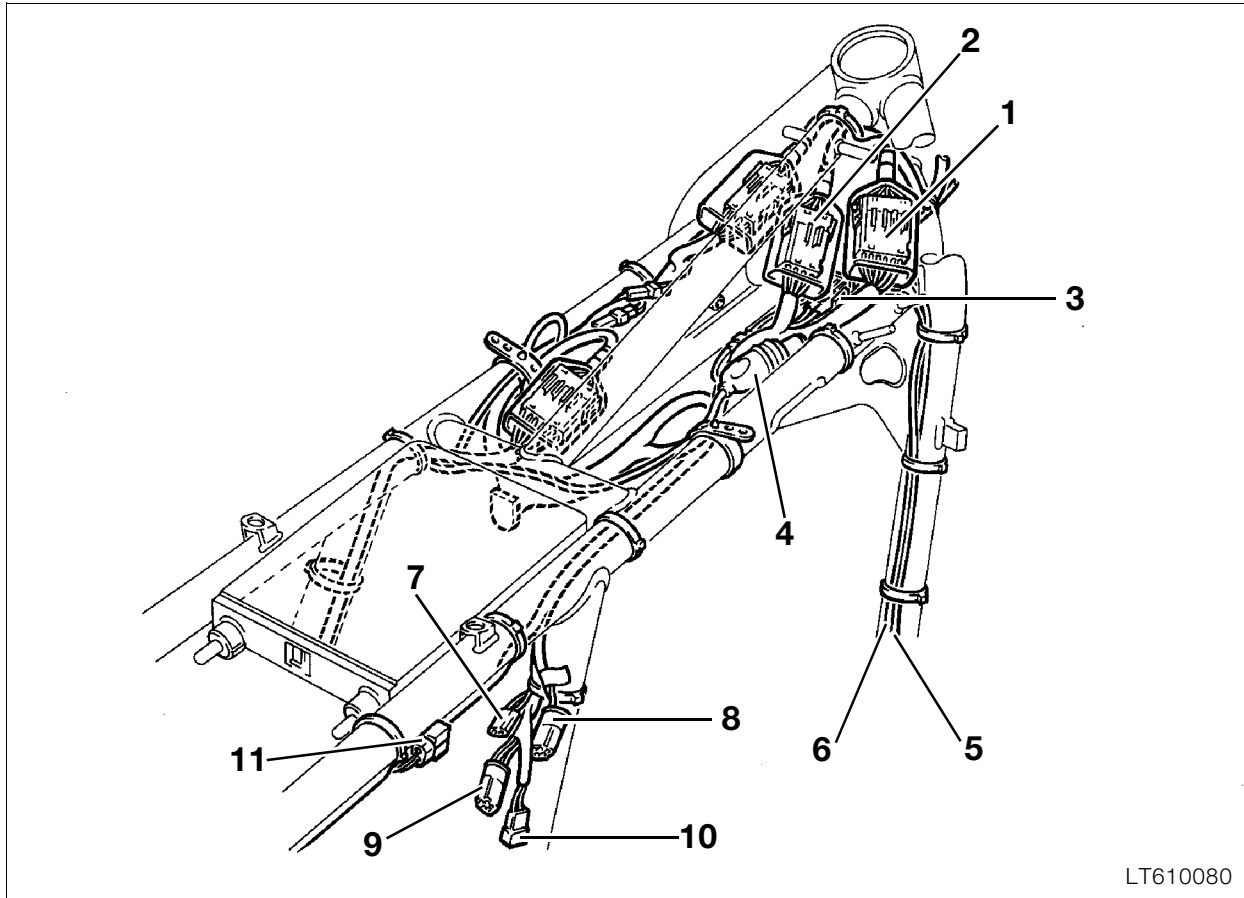

LT610080

View from right

Wiring arrangement fairing bracket, [RS]

1. Right multi-function switch connection
2. Ignition lock connection
3. Handbrake light switch plug connection
4. Hall generator plug connection
5. Hall generator line
6. Oil pressure switch line
7. Brake light switch plug connection
8. Plug connection for fuel pump/fuel warning lamp
9. Transmission switch plug connection
10. Inductive pulse generator plug connection
11. Electric side stand switch connection



Note:

Arrange wiring loom without kinks and chafing points; first install central electrics box. Note arrangement and number of cable clips. Thinly coat central earth (ground) point (metallically bright) with contact grease.

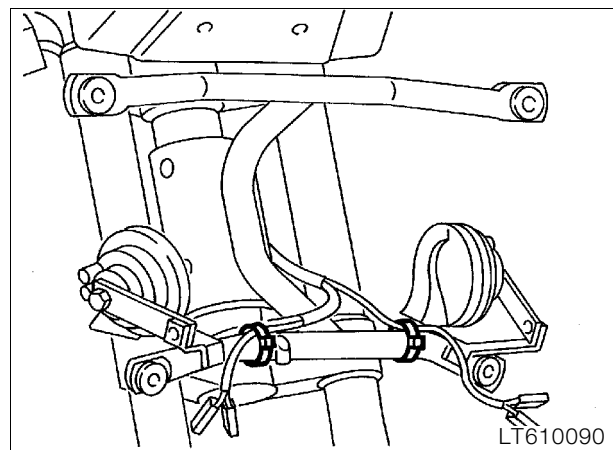

LT610090



Tightening torque:

Earth (ground) connection 9 Nm



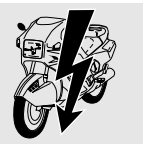

62 Instruments

Contents

Page

Technical Data	3
Removing and installing instrument cluster	5
[LT]	5
[RS]	6
Disassembling and assembling instrument cluster	7
Removing and installing indicator lamp	7
Removing and installing p.c. board	8
Removing and installing quartz clock	8
Removing and installing frame for indicator lamps	8
Removing and installing p.c. board for fuel gauge	8
Removing and installing revolution counter	9
Removing and installing speedometer	9
Removing and installing p.c. board for gear indicator	10





Technical Data	K 1100 LT	K 1100 RS
Instrument cluster		
Turn signal indicator lamps	12 V/4 W T 8/4	
Other indicator lamps, instrument lights	12 V/3 W 10/3	





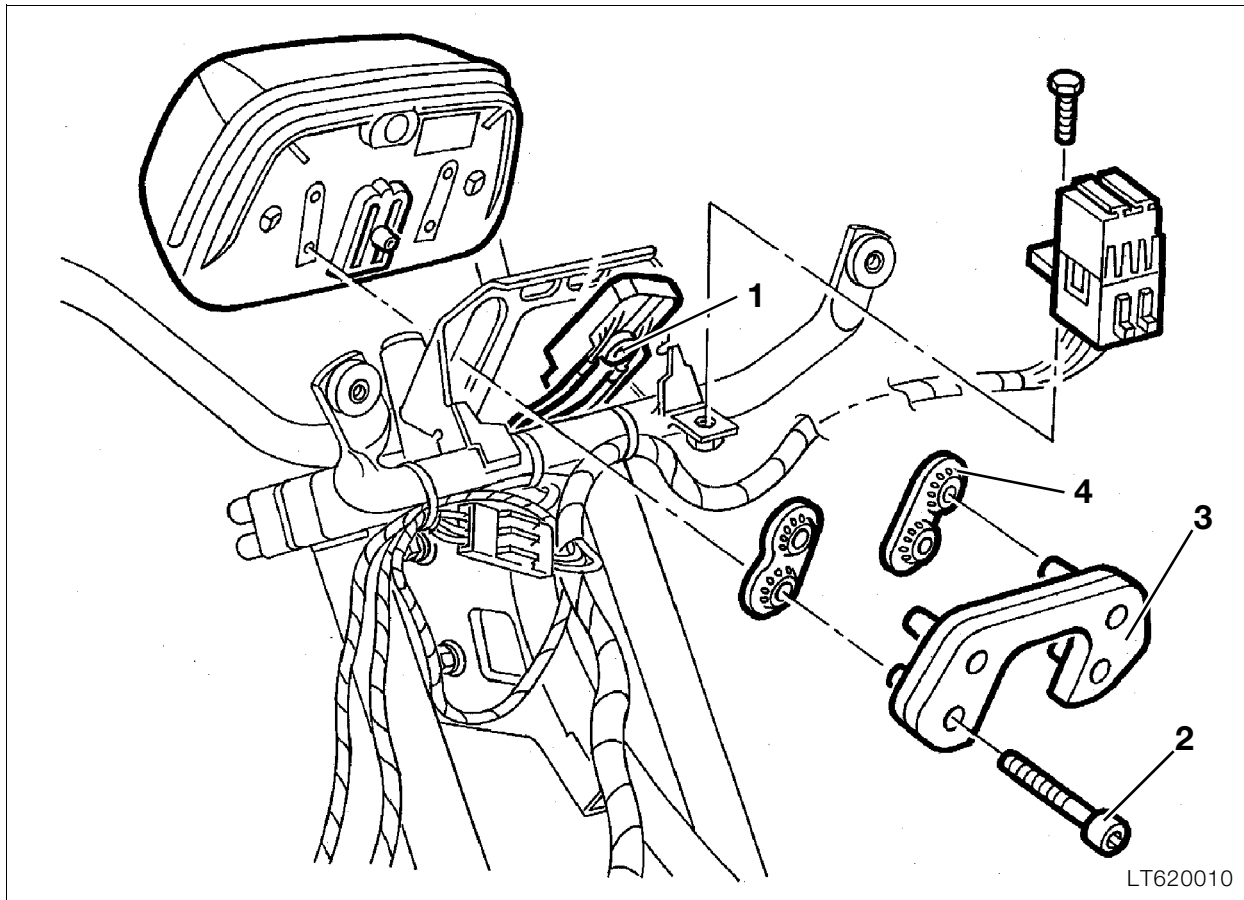

Removing and installing instrument cluster

[LT]

- Remove upper section of fairing.
- Release screw (1) and disconnect central plug connector.
- Release screws (2), remove instrument cluster and counterweight (3).
- Rubber buffers (4) remain in instrument support bracket.
- Install in the reverse order of removal.



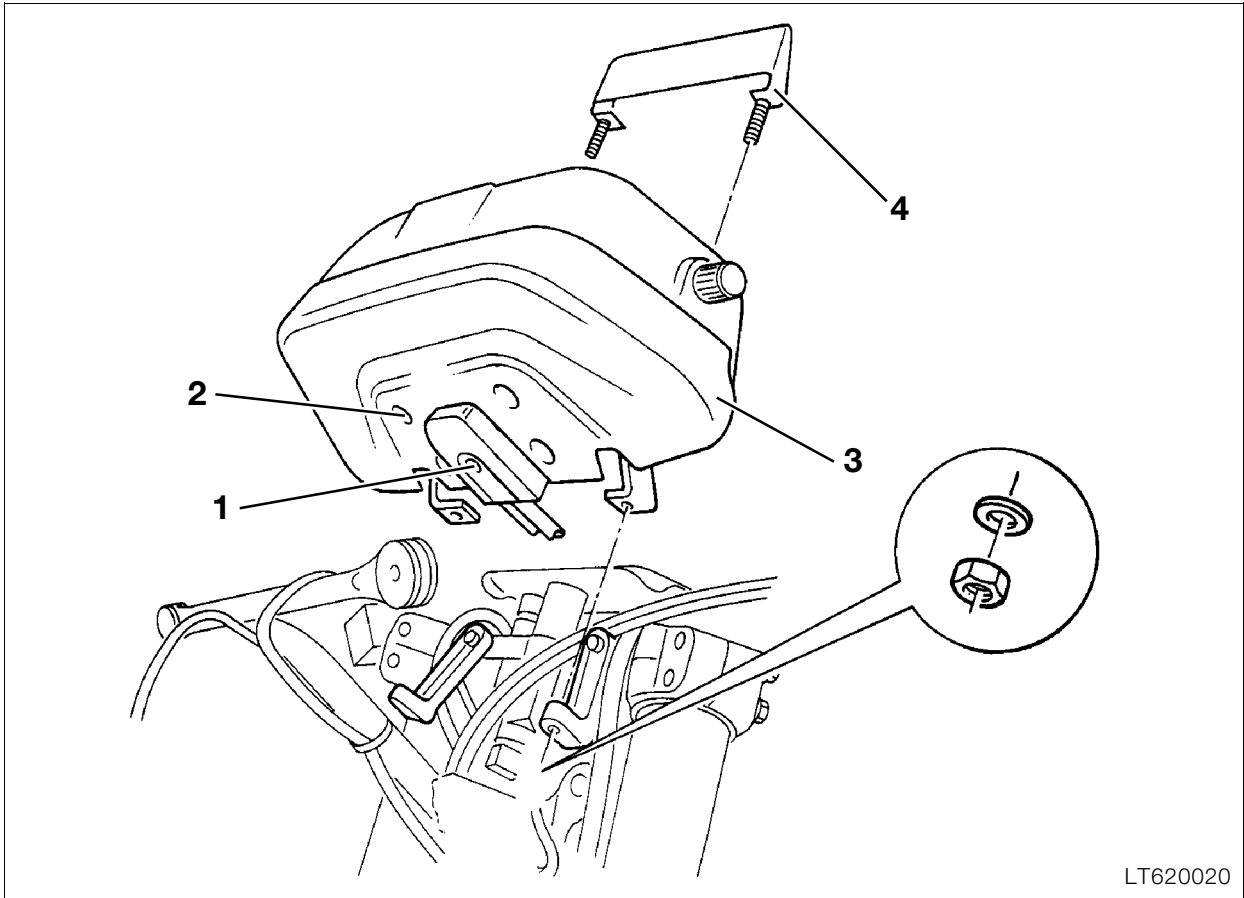

LT620020

[RS]

- Remove upper section of fairing.
- Release screw (1) and disconnect central plug connector.
- Release screws (2) and remove instrument cluster.
- Housing base (3) and cable cover (4) remain on the frame.
- Install in the reverse order of removal.



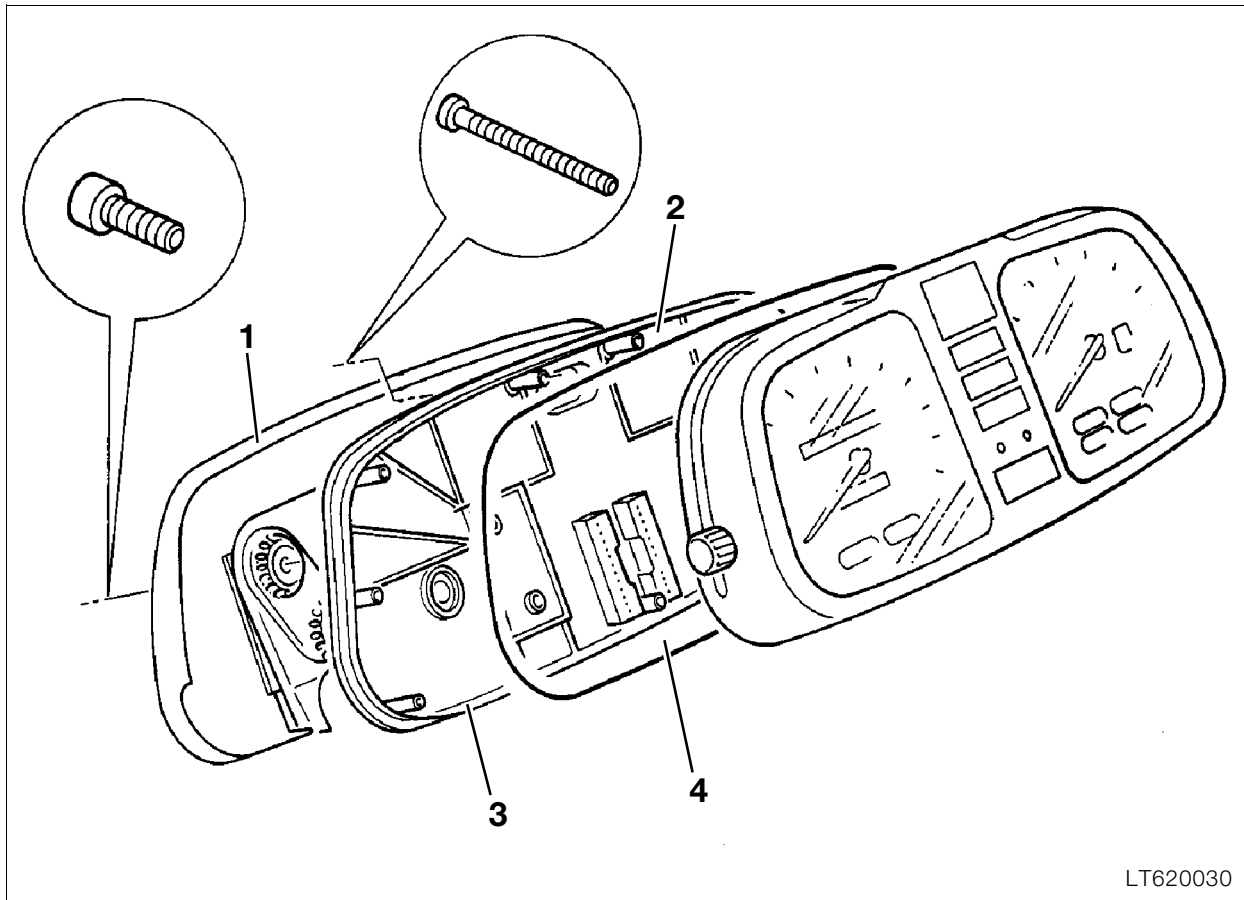

LT620030

Disassembling and assembling instrument cluster

- Release instrument support bracket (1).
- Release housing cover (2) and remove together with gasket (3).
- Instrument housing (4).
- Assemble in the reverse order of disassembly.



Note:

Ensure gasket is fitted in correct position.

Removing and installing indicator lamp

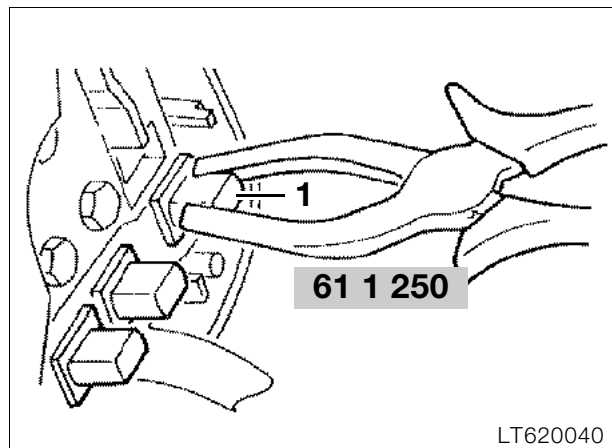

LT620040

- Grip indicator lamp (1) diagonally with relay pliers, **BMW No. 61 1 250**, and pull out or press in.



Note:

Do not damage conductor tracks.

Removing and installing p.c. board

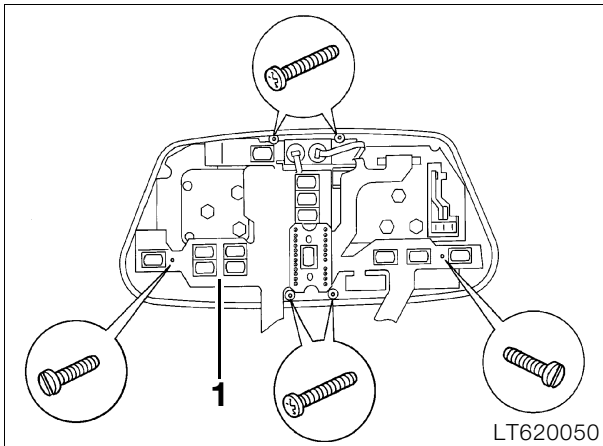

- Release securing screws and carefully lift out p.c. board (1).



Note:

Do not damage p.c. board when removing and installing.
Ensure plug contacts are fitted correctly.

Removing and installing frame for indicator lamps

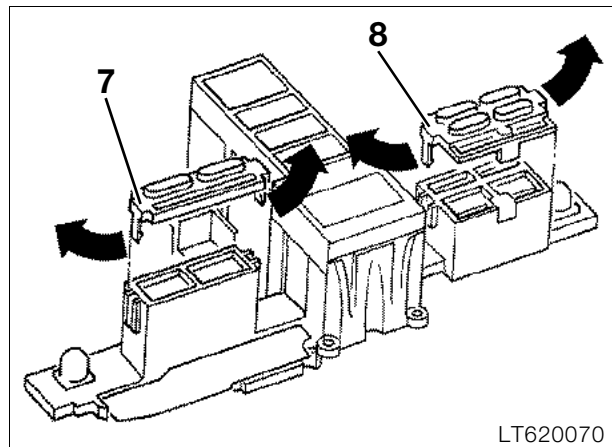

- Carefully press hooks (arrows) towards the outside.
- Carefully lift out frame (7,8).

Removing and installing p.c. board for fuel gauge

Removing and installing quartz clock

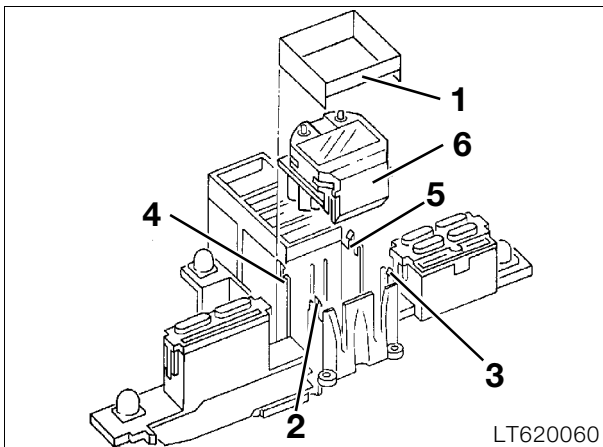

- Carefully remove frame (1) by pulling upwards.
- Carefully press retaining hooks towards the outside in the sequence (2,3) and (4,5).
- Remove quartz clock (6) by pulling upward.
- Install in the reverse order of removal.

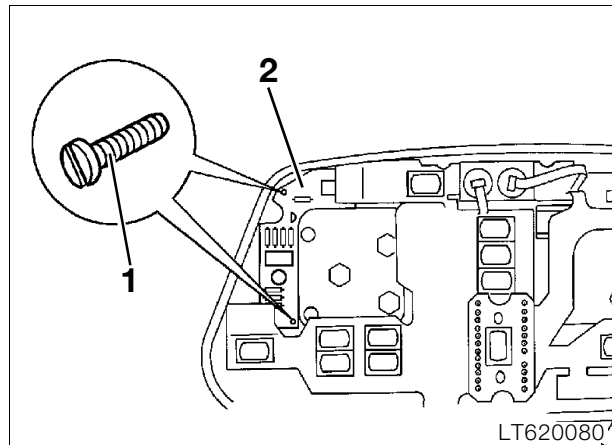

- Release screws (1).
- Lift out p.c. board (2).



Note:

Do not bend p.c. board while installing.

Removing and installing revolution counter

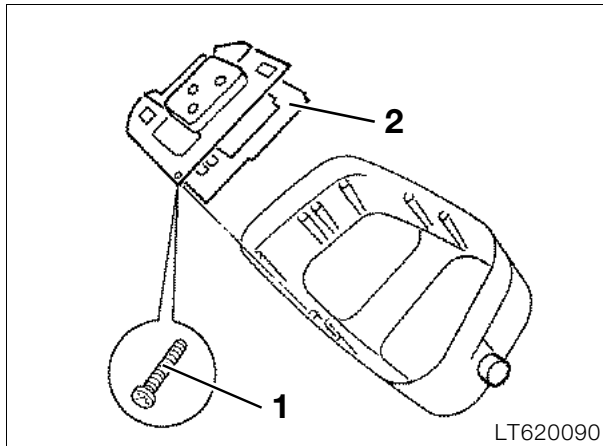

- Release screws (1).
- Lift out revolution counter (2).

Removing and installing speedometer

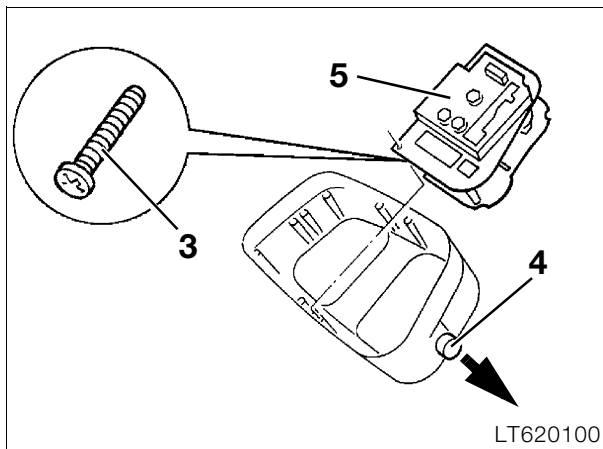

- Release screws (3).
- Completely pull out reset button (4) to the right.
- Lift out speedometer (5).



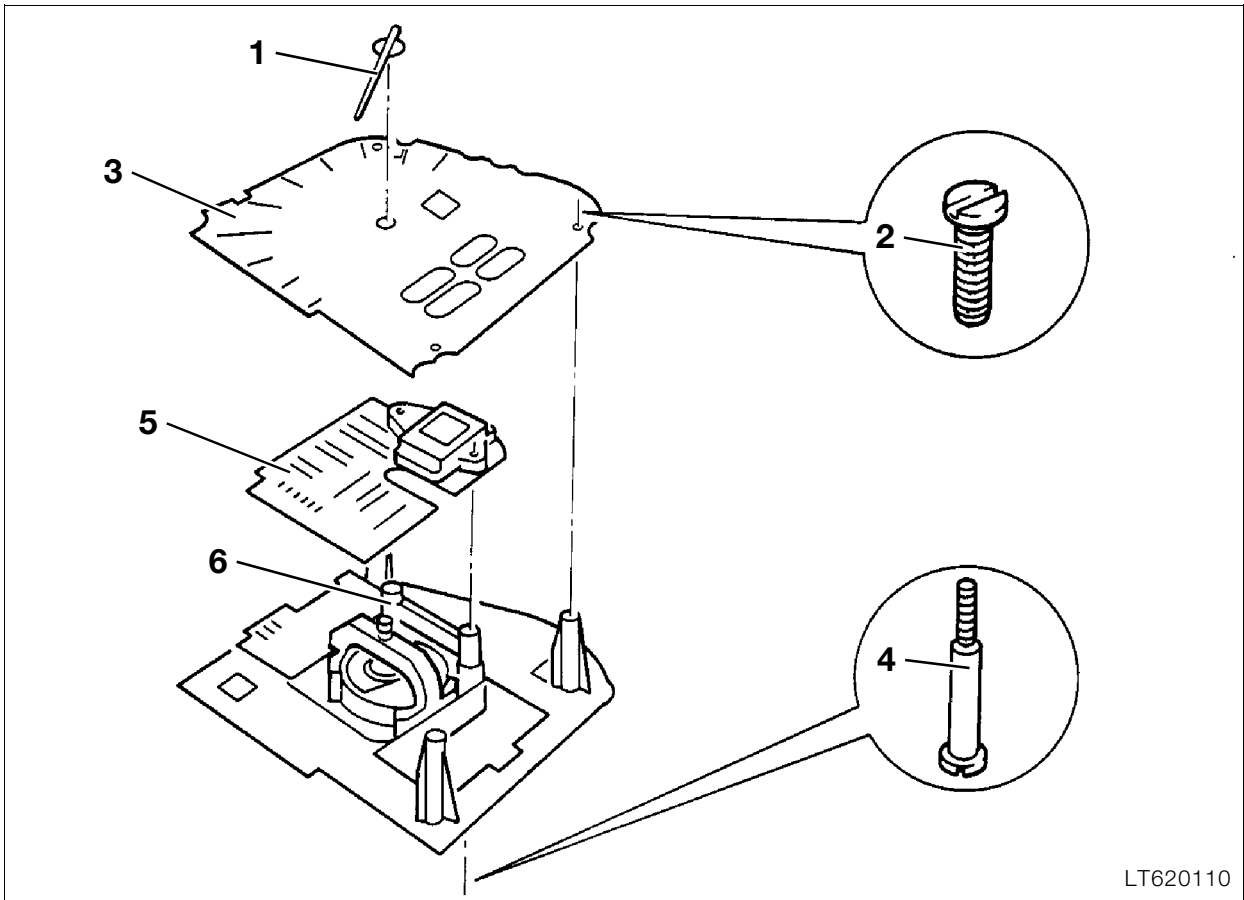

LT620110

Removing and installing p.c. board for gear indicator

- Remove tachometer.
- Carefully pull pointer (1) off the spindle.
- Release screws (2).
- Remove dial face (3).
- Release screws (4).
- Lift out p.c. board (5).



Note:

Note position of spacer (6).

63 Lights

Contents

Page

Technical Data	3
Disassembling and assembling headlights	5
Adjusting headlights	6





Technical Data	K 1100 LT	K 1100 RS
Lights		
Headlight	Halogen rectangular headlight with two-stage manual range adjustment	
Bulbs		
High beam/low beam	H 4 halogen bulb 55/60 W, asymmetric	
Parking light	12 V/4 W	
Rear light	12 V/10 W	
Brake light	12 V/21 W	
Turn signal light	12 V/21 W	





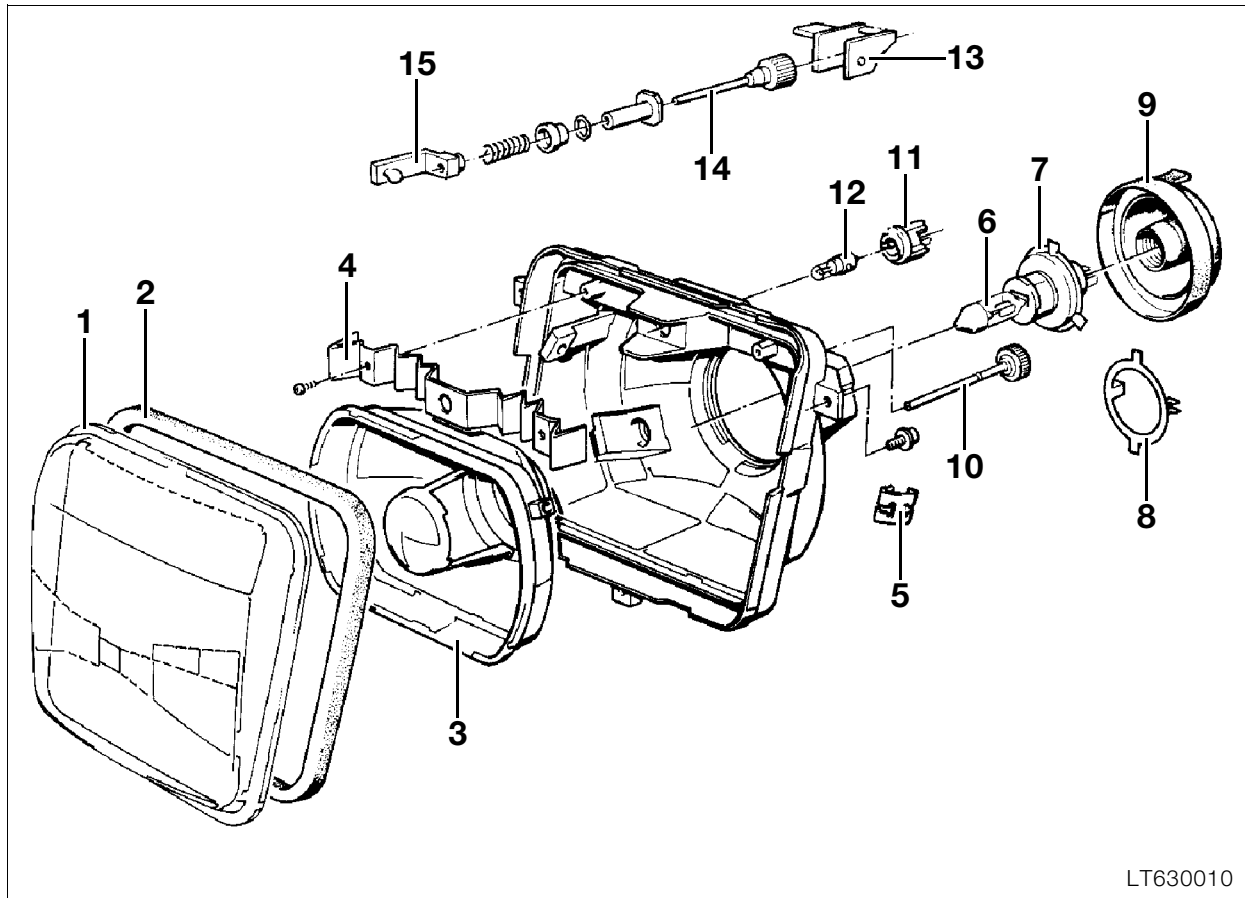

LT630010

Disassembling and assembling headlights

- Remove upper section of fairing.
- Remove headlight.
- Release retaining spring (5).



Note:

Do not touch the inside of the reflector or bulbs with bare hands.

Individual parts:

1. Glass
2. Gasket
3. Reflector
4. Reflector
5. Retaining spring
6. Bulb
7. Bulb socket
8. Retaining spring
9. Cover
10. Adjusting screw
11. Lamp socket
12. Bulb
13. Swivel lever
14. Adjusting screw
15. Bracket



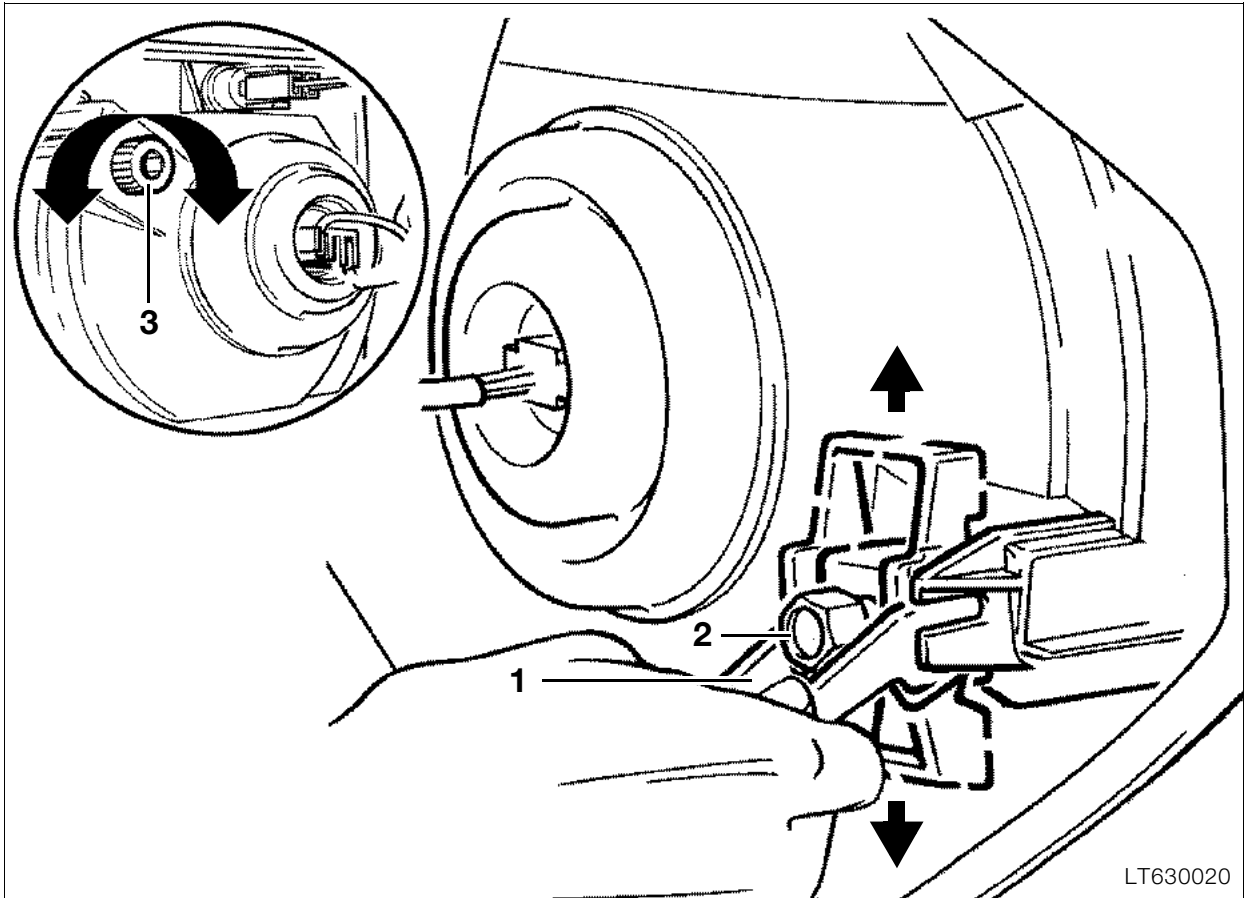

Adjusting headlights

- Engage swivel lever (1) in top position.
- Correct headlight range with adjusting screw (2).
- Turning counterclockwise: shorter
- Turning clockwise: further
- Adjust side angle with knurled screw (3).

